

**EDGERTON PLANNING COMMISSION
MEETING AGENDA
EDGERTON CITY HALL - 404 EAST NELSON STREET
June 9, 2026
7:00 P.M.**

The City of Edgerton encourages public participation in local governance issues. To facilitate an efficient and effective meeting, persons wishing to address the Planning Commission must sign-up before the meeting begins. During public hearings, comments must be limited to three (3) minutes per speaker. The maximum time limit for all speakers during each public hearing will be one (1) hour.

The chair may modify these provisions, as necessary. Speakers should state their name and address and then make comments that pertain to the public hearing item.

The chair may limit any unnecessary, off-topic, or redundant comments or presentations. Speakers should address their comments to Planning Commission members only and should not speak to fellow audience members. Commission members will not engage in a dialogue or debate with speakers. Speakers and audience members should conduct themselves in a civil and respectful manner. Disruptive conduct may result in removal from the meeting.

Call to Order

1. **Roll Call** _____ Draskovich _____ Mathos _____ Little _____ Mueller _____ Soemer
2. **Welcome**
3. **Pledge of Allegiance**

Consent Agenda (*Consent Agenda items will be acted upon by one motion unless a Planning Commissioner requests an item be removed for discussion and separate action.*)

4. Minutes from the May 12, 2026 Planning Commission Meeting.

Regular Agenda

5. **Declaration.** At this time, Planning Commission members may declare any conflict or communication they have that might influence their ability to impartially consider the agenda items.
6. **Public Officials Liability Training**

Business Requiring Action

7. **PREVIOUSLY TABLED FROM MAY 12, 2026 - FSP2026-0002: FINAL SITE PLAN FOR EDGERTON PROJECT LOCATED AT 31800 W 196TH STREET**
 - a. Presentation from Representatives from DAMAC Digital, applicant for Final Site Plan Application FSP2026-0002
 - b. Presentation from City Staff for Final Site Plan Application FSP2026-0002
 - c. Discussion of Final Site Plan Application FSP2026-0002

d. Consideration of Final Site Plan Application FSP2026-0002

8. Future Meeting Reminders

- July 14, 2026 at 7:00 PM – Regular Session
- August 11, 2026 at 7:00 PM – Regular Session
- September 8, 2026 at 7:00 PM – Regular Session

9. Announcements

10. Adjourn

PLANNING COMMISSION
May 12, 2026 Minutes

A regular session of the Edgerton Planning Commission (the Commission) was held in the Edgerton City Hall, 404 E. Nelson Street, Edgerton, Kansas on February 10, 2026. The meeting was convened when Chair Tina Mathos called the meeting to order at 7:02 PM.

1. ROLL CALL

Jeremy Little	present
Tina Mathos	present
Adam Draskovich	present via videoconference
Ray Soemer	present
Jordyn Mueller	absent

With a quorum present, the meeting commenced.

Staff in attendance:

- Zachary Moore, Development Services Director
- Chris Clinton, Planning and Zoning Coordinator
- Hailey Vaughn, Customer Service Representative II
- Beth Linn, City Administrator
- Todd Luckman, City Attorney
- David Hamby, City Engineer
- Dan Merkh, Public Works Director
- Kara Banks, Assistant to the City Administrator
- Trey Whitaker, Assistant to the City Administrator
- Joe Kmetz, City Building Code Official

Elected Officials in attendance: Mayor Donald Roberts

2. **WELCOME** Chairperson Mathos welcomed all in attendance to the meeting.
3. **PLEDGE OF ALLEGIANCE** All present participated in the Pledge of Allegiance.

Chairperson Mathos informed all present that the meeting will be conducted with dignity and respect for all attendees and participants. She stated it is important that the Commission has the ability to conduct business as provided on the agenda.

CONSENT AGENDA

4. Minutes from March 10, 2026, Planning Commission Meeting.

Commissioner Little moved to approve the Consent Agenda. The motion was seconded by Commissioner Soemer. The Consent Agenda was approved, 4-0.

Regular Agenda

5. **Declaration.** Chairperson Mathos requested that the Commissioners declare any correspondence that they have received or any communication they have had regarding the matters on the agenda. She asked them to state if any correspondence or communication might influence their ability to impartially consider the items on the agenda.

The Commissioners did not have anything to declare.

Business Requiring Action

6. **PP2026-0001: PRELIMINARY PLAT FOR EDGERTON PROJECT LOCATED AT 31800 W. 196TH STREET**

Chairperson Mathos requested Mr. Todd Luckman, City Attorney, explain what a Preliminary Plat application is and what the application does as part of the overall development process.

Mr. Luckman explained the application before the Commission is for a Preliminary Plat. A Preliminary Plat is a requirement of the Unified Development Code (UDC) and is not about zoning. In the past the Commission has considered rezoning cases which take into account the Golden Factors and quasi-judicial finding. The Preliminary Plat is not about zoning and does not require review pertaining to the Golden Factors. Mr. Luckman explained that a plat is a map of a property in horizontal form. The map can be separated into different tracts and may have dedications to the City or public for utilities and other things. The plat is to be reviewed under the requirements listed in the UDC. This application does not take into consideration any tax or zoning implications. He stated the Commission will have three (3) options for the application; approve, deny, or table with instructions which is sending the application back to the applicant for more information. Mr. Luckman said in the Kansas Court of Appeals case Rodrock Enterprises versus the City of Olathe in 2001, The Court ruled that approval of a plat is improperly denied if a plat conforms to all zoning subdivision regulations and Planning Commission standards. He continued that denial must be based on a violation of regulations and standards which are within the authority enabling legislation, which is the UDC. The UDC requires a reason for denial of a plat. This is set upon the idea that the requirements in the UDC are met or not. If a Commissioner wishes to deny the plat, the code sections that are not met must be provided.

Chairperson Mathos asked the applicant to present their request.

Ms. Chelsea Kulhanek, Director of Development with DAMAC Digital, spoke before the Commission. She explained that the application is for an adaptive reuse project. They intend to take a vacant industrial building in Logistics Park Kansas City (LPKC) and bring it back into use in accordance with the standards previously approved by the City. She said they are not requesting a rezoning, Comprehensive Plan amendment, or variance of any kind. The property is zoned for the proposed use and complies with all development standards. She explained that City staff does recommend approval of plat and site plan after their review. Ms. Kulhanek said DAMAC Digital is a privately held global developer that was founded in 1982 and headquartered internationally. DAMAC Digital has built data centers all over the world. Edgerton would be a piece of their United States portfolio and will represent a long-term capital investment in the City. Their engagement with City staff, leaders and the community does not end after the meeting. The applicant understands there is interest and questions

beyond the scope of the applications being presented to the Commission. This is why they held an Open House prior to the meeting. She closed by saying that DAMAC Digital is here to present their application for a plat and site plan and consistent with City staff's recommendation, they request approval of those applications as submitted.

Mr. Jeff Skidmore, Civil Engineer from Schlagel and Associates, addressed the Commission regarding the Preliminary Plat. He stated the location is 31800 W. 196th Street. The proposal is made of three (3) parcels, and this would be a replat of the existing lot with two (2) parcels to the north. The parcels extend to W. 191st Street. This would be incorporating all three (3) parcels into one (1) lot under single ownership, which will be the developer. This Preliminary Plat supports the proposed site plan to be presented to the Commission later during this meeting. All existing easements are platted and indicated on the Preliminary Plat. There is a tributary of Bull Creek that divides the parcels on the north, and the City has requested that the floodplain be in a drainage easement, which will be done.

Chairperson Mathos requested City staff present the staff report and review of the application.

Mr. Zachary Moore, Development Services Director, addressed the Commission. He explained City staff's role when considering a Preliminary Plat. City staff receives an application from the property owner or their representative and reviews the application against UDC and any other applicable documents, studies, master plans adopted by the Governing Body. Based on that review, City staff makes a recommendation that is found in the Staff Report.

Mr. Moore stated the application is for a Preliminary Plat for 53.79 acres located at 31800 W. 196th Street. He said there is a previously developed lot that has an existing warehouse on it. That portion of the subject property was annexed into the City of Edgerton in March of 2014 and was later rezoned to the Logistics Park (L-P) zoning district in December of 2017. A Final Plat was approved in 2016 and recorded in 2017 that also included lots to the east. The property is currently developed under a Final Site Plan that was approved in April of 2016 with a 378,038 square foot warehouse. The other two (2) parcels indicated on the Preliminary Plat are north of the developed parcel and were annexed into the City of Edgerton in August of 2018, then rezoned to L-P in October of 2018. Mr. Moore said the Preliminary Plat proposes the property be on one (1) lot comprised of 53.79 acres. There are no privately owned common tracts proposed, nor are there any dedicated rights-of-way. There is a section of floodway that will need to be in either a drainage area or a privately owned common tract, which is listed as a stipulation as part of City staff's recommendation. He explained the Preliminary Plat does propose a 50-foot building setback along the south property line, and 25-foot setbacks along the east, west and north property lines. Those proposed setbacks do meet the requirements of the UDC for the L-P zoning district. Mr. Moore said the UDC does require a public hearing for Preliminary Plat applications. In accordance with the prerequisites of the UDC, the applicant posted signs and sent mailers via certified mail. He stated City staff recommends approval of Application PP2026-0001 with the following stipulations:

1. The commencement of any improvements cannot occur prior to the approval and endorsement of the Final Plat by the Governing Body and the submittal and approval of construction plans for all streets, sidewalk, stormwater sewers, sanitary sewers, and water mains contained within the Final Plat.

2. The applicant must meet all requirements of Recording a Final Plat as defined in Section 13.5 of the Edgerton UDC, and all requirements of Financial Assurances as defined in Section 13.7 of the Edgerton UDC.
3. The 100-year floodway and floodplain must be shown in a drainage easement of tract on the Final Plat.

Chairperson Mathos explained that a public hearing is required for this application. She said that during the public hearing, comments must be limited to three (3) minutes per speaker, with the maximum time limit for all speakers during each public hearing being one (1) hour. Speakers must state their name and address before making comments that pertain to the public hearing item. Speakers must address their comments to the Commission members only and should not speak to fellow audience members during their public comment. Commission members will not engage in a dialogue or debate with speakers. Speakers and audience members should conduct themselves in a civil and respectful manner. She warned that disruptive conduct may result in removal from the meeting.

Chairperson Mathos opened the public hearing at 7:15 PM. She stated that prior to calling the first speaker up, City staff will read the names and addresses of written comments submitted to the City preceding the meeting. City staff will indicate if the comments were in support, opposition, or neutral in nature.

Ms. Hailey Vaughn, Customer Service Representative II, read the names, addresses, and nature of the comments. All of the correspondence received prior to the meeting are attached to these minutes.

Chairperson Mathos explained the procedure for those who wish to speak and requested the first speaker be called.

Mr. James Oltman, ElevateEdgerton! President, approached the Commission. He stated he is here in support of the Preliminary Plat. He believes this is the type of development that the City has spent years preparing for. The City recently went through a two (2) year process to update the Comprehensive Plan and Future Land Use Map. During that time, the City received a lot of feedback from Edgerton residents and the surrounding areas for maintaining industrial development within LPKC and away from residential neighborhoods. He stated that this proposal does exactly that. The property is within LPKC and is zoned for industrial uses. This is a permitted use under the property's zoning regulations. The project is aligned with the vision, planning, and zoning framework that the City and the Commission has established. Mr. Oltman explained there are about a dozen other facilities in the area that have been in operation for years. There have been no substantial instances where there have been complaints about noise, water issues, lighting issues, or anything of that nature. The City has received feedback about traffic and roadway safety in LPKC, and this project has less truck traffic on local and regional roads compared to traditional warehouses and distribution operations. This would lead to less congestion, fewer trucks and fewer impacts on the surrounding transportation infrastructure in Edgerton and the surrounding community. Mr. Oltman said this project may not produce the same quantity of jobs as other warehouse operations, the jobs that are created are high quality and high paying jobs across a wide variety of technical, operational, maintenance and professional fields. These jobs will be available for current Edgerton residents and will help attract future residents. He stated this

project represents a substantial investment in Edgerton and will generate significant tax revenues that will help support important community infrastructure projects. Those projects include streets, utilities, and wastewater improvements. The tax revenues will help lessen the impact on current residents while supporting the growth of the community. This project reflects many priorities the community identified during the Comprehensive Plan process: keeping industrial development in LPKC, reducing truck traffic impact, supporting quality jobs, and generating revenue for community infrastructure. Mr. Oltman encouraged the Commission to support this project.

Mr. William LaFalce, 516 W. 4th Street, Edgerton, KS, addressed the Commission. He stated that he is a 30-year resident of Edgerton, and he is present to voice his opposition of what he believes is the toxic triangle that the outsiders are trying to bring in. He believes DAMAC personnel are not being truthful based on what is happening around the country. He stated there will be massive water consumption, air and noise pollution, especially with the backup generators. There are public health risks from data centers, particularly ones powered by fossil fuels, and electromagnetic radiation. He said there will be high energy demand, impacting other customers. Mr. LaFalce stated that a data center in Georgia illegally used 30,000,000 gallons of water, which resulted in water shortages where people couldn't flush their toilets. He added this will also impact emergency services because without water pressure, there can be no fire department. He said there needs to be oversight and it is not needed in the community. He stated that the data centers need to be regulated by guard rails, binding, large load tariffs, to ensure that the data center is required to pay for any services and rate allocations to ensure they pay their own share. There needs to be federal, state, and local oversight on how much power the data centers draw. He stated a certain amount of power must be renewable and that they pay their own share. Mr. LaFalce stated that to fight the battle, he has enlisted the aid of the Sierra Club, and they will fight with legislation and litigation and hold each and every person who supports the data center accountable. He said that there has to be openness. He inquired if anyone has signed nondisclosure agreements (NDAs) and if so, who are they and what are those NDAs. He said they have the right to know. He wanted to know what company is behind the data center, is there any community benefit, and are they going to be paying their portion of local taxes or are the residents going to carry the burden. He asked if the data center fails and the building is abandoned, will the City be stuck with a Love Canal, Flint, MI, or an Environmental Protection Agency (EPA) supersite that cannot be cleaned up. He stated that recently the Panasonic battery plant to the north had thermal events and he does not think the emergency services are equipped to handle a data center sucking up the water, polluting the air, impacting livestock and personal health, and ruining the water.

Mr. John Van Hercke, 301 W. McDonald Street, Edgerton, KS, spoke before the Commission. He stated he moved to Edgerton in 2020, and his water bill was \$40 per month and now it is up to \$150 per month. He claimed this increase is caused by the warehouses not paying their fair share. He said he is tired of his taxes, water bill, and electrical bills go up because the City is not making people pay their responsibilities and shifting it onto the residents. Mr. Van Hercke said that data centers represent a profound misallocation of our most precious resources; land, water, energy, community well-being, in service to an industry that prioritizes endless digital expansion over human and environmental health. He said they are not neutral infrastructure, and they are industrial-scale users that externalize massive cost onto ordinary people while delivering concentrated benefits to a few tech giants. Data centers are voracious

with a single large facility consuming the same amount of energy as 100,000 households. He asked how many households there were in Edgerton. He said projections showing US data center electricity use reaching 12% of the national total by 2028. Artificial Intelligence (AI) driven demand is accelerating this trend and running models contribute already tens of millions of tons carbon dioxide (CO₂) annually. Forecasts show 24-44 million metric tons more per year by 2030 from AI centers alone. Mr. Van Hercke said that it is equivalent to adding 1,000,000 cars to the road. The water use is equally shocking, with mid-to-large data centers gulp up one (1) to five (5) million gallons of water daily for cooling. He said that it is comparable to a small town's entire water supply. He said a Google facility averages 450,000 gallons of water per day. In water stressed areas, this strains supplies, raises bills, and competes with agriculture and drinking water. He said there is still agriculture near Edgerton, and he wants to see them get watered. Energy production for them adds further water and emission burdens.

Ms. Jill McCarthy, Kansas City Area Development Council, approached the Commission. She stated she has the privilege to work with cities on either side of the state line to help bring in new businesses, create jobs, and capital investment into the region. She said she has worked with data centers for more than 25 years with clients like Liberty Mutual, the United States Department of Agriculture (USDA), State Farm, Mastercard, and the Marine Corps Information Technology Center that services the Marine Corps around the world. She explained data centers service things that people use daily, like emails and social media. Data centers are also the backbone of the industrial society. She explained that the nation's defense system and military all around the world rely on data centers to get information they need in a timely manner. Every financial transaction that is made goes through a data center. Educational presentation, research and medical research need data centers. Ms. McCarthy stated that when a patient goes into a hospital, doctors have access to their medical records due to data centers. There are things that happen in data centers that people don't recognize about daily lives. She said we are in a critical time as this is the next wave of opportunity of the haves and have-nots globally and the ability to have commerce and innovation in the community. There is a data center that the USDA and others use for AI that is able to identify crops with illnesses prior to naked eye and provide corrective action. She said she is in support of this proposal.

Mr. Shane Mizer, 505 W. Edgewood Drive, Edgerton, KS, spoke before the Commission. He said this month marks 25 years since he moved to Edgerton. In that time, there has been a lot of positive growth as well as just growth. He stated the intermodal facility has brought a lot of positive growth, but he does not see a data center as a positive thing. A speaker earlier said there would be no extra truck traffic and that is because there are no jobs. He stated that Edgerton does not have the power to support a data center. He inquired to how many transmission lines Evergy will have to put in and to the location of the lines. He asked if private property would be condemned for the power lines, if they would be going through schools, or through people's backyards. He asked who is going to pay for that infrastructure and he believes Evergy is going to distribute that cost to everyone who signed up for it. He claimed that DAMAC will not pay for it. In April of 2025, the state of Kansas approved a tax abatement of 20 years. He asked if that was going to be offered to this project to where the residents will not see any benefit from the project. He stated residents are not seeing jobs or benefits, just more data there. In terms of watershed, they will be pumping off of Hillsdale Lake, which is a 4,500-acre reservoir. He said in 2022, 56,000 people in four (4) counties were sharing

that water. Also in 2022, it was estimated that by 2050, 156,000 residents using water from Hillsdale Lake. He said he does not know the megawatts this data center will be, but it can use two (2) to five (5) million gallons of water a day. Mr. Mizer wonders how long Hillsdale Lake can support that usage and will new facilities be needed now. Those are questions that need to be answered. He also wants to know what will happen to the water that enters the cooling towers. He said there will be chemicals going in and out of the water and it has to be filtered.

Ms. Courtney Crawford, 30842 Indianapolis Road, Paola, KS, addressed the Commission. She stated she is running for Kansas House of Representative, District 5 and has been to several City Council meetings across District 5 and this isn't the first data center proposed in the District. She requested the Commission consider a one (1) year moratorium on data centers as we do not know what the impacts are on the community and resources. She stated the question was raised of why Kansas, why Edgerton, and why not Dubai where the owners of DAMAC are. The reason she was given was that there are resources available here. She stated that those are the community's resources and not theirs. Studies need to be done, and a one (1) year moratorium needs to be in place to do those studies.

Ms. Kailey Dressler, 217 W. Colleen Drive, Gardner, KS, approached the Commission. She said she wants to bring to light numerous red flags in the literature provided on the website. The water-cooling system may be closed loop for now, but that leaves the door open so that the system will be water cooled later. She stated in March of 2026, Amazon settled for \$20,500,000 in northeast Oregon for contaminating the ground water for no admission of guilt to avoid additional litigation. In Georgia, 30,000,000 gallons of water was used and not disclosed. Ms. Dressler inquired as to how the dedicated power will be generated, if the applicant will create their own power and if they will be using gas turbines. She said gas turbines emit smog forming pollution, fine particulate matter, and chemicals like formaldehyde that travel for miles and will affect many surrounding communities. There are more than 6,500 young children within a five (5) mile radius from the proposed site that are at a heightened risk for complications from such pollution. The diesel generators will be claimed to be used as backup power only but will have monthly testing and use is not held to any time limits, provided that the operator logs the number of hours and the emergency. The generators will emit harmful noxious fumes, such as nitrous oxide, fine particulate matter, sulfur dioxide. This will lead to health issues such as asthma, respiratory infections, cardiovascular disease, and increased cancer risks. She said there are currently lawsuits being filed on account of those affects in Mississippi. Ms. Dressler wants to know what site-specific items are being proposed to mitigate the noise. She stated noise pollution is not adequately controlled by acoustic engineering and has massive health implications for those within miles of a data center such as headaches, vertigo, nausea, sleep disruption, ear pain and high blood pressure. Monthly testing will be done on the generators, and that alone can reach 105 decibels (dB), which is the equivalent to a jet engine. She showed a photo that is supposed to be five (5) miles from a data center and said that the lighting is not controlled. Ms. Dressler said the last statement on the website is that there will be ongoing engagement with local organizations, transparent communication, and investment in Edgerton's long-term growth. Those are vague statements and can easily be refuted on their base with available information on existing data centers and is a stark disconnect between empty promises and the harsh realities communities that are home to data centers are currently facing. She quoted a question from the Frequently Asked Questions in the packet about living next to a data center.

The answer stated that data centers are among the quietest and least disruptive types of commercial development a community can host. She asked if 105 dB quiet and do not forget the 24/7/365 persistent low frequency hum and buzz that is audible for miles that is driven by cooling systems; heating, ventilation and air conditioning (HVAC) units; and server fans.

Mr. Dalton Van Houtan, resident of Gardner, KS, spoke before the Commission. He said he has been in the Gardner-Edgerton area since 2007. He said it is interesting how many lawyers and corporate sponsors have shown up to the meeting, it is almost as if they are desperate to pass it through. He begged the Commissioners to read between the lines and see them for what they are. He explained emotion is fueling his speech, but he will present only facts. If some of the facts have been presented before, he finds them worth repeating. He stated the closed-loop cooling is misnomer and myth. The total amount of water needed for the initial filling is still undisclosed. There will also be flushing for regular changes every five (5) to ten (10) years. The daily water usage, what the applicant refers to as domestic use for kitchens and bathrooms, will total 15,000 to 20,000 gallons of water. This will be taken from residents' water supply and 90-95% of it will be returned as wastewater to be treated. Multiple sources across the country are experiencing contaminated water containing treated chemicals such as biocides, anticorrosion agents, concentrated minerals like scale and heavy metals picked up from the system. If the wastewater is not managed properly it can pollute local waterways and over burden wastewater treatment plans. Mr. Van Houtan stated that hyperscale data centers use large generators scaling about the size of a mobile home. While these are not the main power source, they will be used during any outages. They will also be allowed to do weekly, monthly, and annual tests on the generators. The weekly tests can take between 30 to 60 minutes, and because this is a hyperscale data center, there will be anywhere between 30 to 400 of the generators running at one time. The generators will pump out numerous forms of pollution such as nitrogen oxides, fine particulate matter, and carbon dioxide burning hundreds of gallons of diesel fuel per generator per hour. These fumes and pollution will impact people, animals, and plants within a few miles of the facility but can travel hundreds of miles up in the air current. He said data centers create light pollution as well. Hyperscale facilities require all-night lighting that will disrupt natural circadian rhythms of the body including melatonin production and sleep-wake cycles. Light pollution is also disrupting migration patterns and habitat development for birds, butterflies, bats, cats and turtles. The long-term impacts of both noise and light pollution include hearing loss, stress, insomnia, and decreased quality of life.

Ms. Laura Seifert, 204 W. Nelson Street, Edgerton, KS, addressed the Commission. She urged the Commission not to allow a data center for multiple reasons. She stated data centers are ravenous consumers of resources like water. Her water pressure is low on a daily basis and she is not interested in it becoming a trickle due to a data center taking away from an already weak resource. Data centers jeopardize health of both people and nature. Chemical gasses emitted from a data center in Georgia were exceeded by a diagnosis of pulmonary issues such as Chronic Obstructive Pulmonary Disease (COPD) and bronchitis in residents with no prior history of those issues. Edgerton residents deserve the peace of clean, quiet air that comes from the breath of God alone. Ms. Seifert said that a study of infrasound, sound that is imperceptible to the human ear, in data centers from around the country showed high numbers of people feeling the effects of the infrasound. Some of those side effects are nausea, dizziness, anxiety, irritability, gastrointestinal (GI) problems, and other issues. Edgerton residents deserve to be free from the hidden problems and mysterious health issues

that are more than likely to sprout up with the implementation of a data center. She is worried about environmental impacts a data center will have to the native ecosystem. She has noticed Monarch butterflies in the last few years. She said her husband is a beekeeper who enjoys watching the bees build and forage. She also enjoys seeing the foxes bound in the fields behind her house and the feral cats hunting. She does not want to think what the pollutants from a data center would have on the pollinators and local wildlife.

Ms. Kelly Johnson, 216 E. Westhoff Place, Gardner, KS, approached the Commission. She stated she is a current City of Gardner City Council member; however, she is not representing the City of Gardner, nor any other councilmember, at this meeting. She said the City of Gardner has received an application for a data center which has led her to research the issue, reviewing public materials, and listening to residents of the area. She urged Edgerton to exercise substantial caution before approving a data center project. It is clear that many Edgerton and nearby residents have serious concerns about these projects. She said public opposition alone should not govern policy; she believes that local governments do have a responsibility to give substantial weight to community concerns when considering development that may permanently determine the character, infrastructure demand, resident health, and long-term economic direction of a region. She said it should be carefully evaluated if a data center is the highest and best long-term use of strategically, valuable, industrial areas. Industrial zoning alone should not automatically justify approval of every industrial use; particularly when the long-term impacts remain uncertain. Ms. Johnson said data centers typically require a substantial amount of space, electrical capacity, and infrastructure investment while producing relatively few permanent jobs compared to many other industrial or commercial developments. Once land is committed to a project of this scale, it may remain tied for that single use for decades potentially eliminating future economic flexibility and diversification. She said she believes there should be careful consideration of the proper infrastructure implications associated with these facilities, including regional electrical demand, transmission capacity, water usage, backup power systems, and long-term utility impacts. These are not concerns isolated to a single municipality as neighboring communities often feel the effects of large-scale industrial development. She is concerned about the lack of clearly independent, peer-reviewed research regarding long-term environmental, health, and community impacts of data centers located near growing residential areas. She said that during her own research, she found that many articles, studies, and position papers can be traced back to organizations, companies, advocacy groups, and individuals with a direct financial or political interest to either support or oppose these projects. She was unable to find neutral, long-term, peer-reviewed research that addresses the concerns raised by many of the residents. In the absence of strong, independent data, she believes that municipalities should use exercise caution before approving projects with a potentially significant, and potentially irreversible regional impact. Local governments are often asked to make decisions whose consequences will go far beyond current council and committee terms. Caution is warranted as the long-term effects remain uncertain. She said independent studies and regional analysis are warranted.

Ms. Kim Twente, 705 W. Meriwood Lane, Edgerton, KS, spoke before the Commission. She said she is opposed to the data center for many of the reasons that have been said, but it needs to be said as many times as possible, so it is heard. She said that there are not enough studies on the long-term impacts of data centers because they have become an overnight, throbbing of being put everywhere. There have been enough recent studies that have shown

that they are not beneficial to communities. She said in an article by Tao and Gao, they call for empirical research because data centers are so terrible for environments with noise levels reaching well above the 85 dB threshold to be considered harmful to hearing. The persistent noise adversely affects data center staff, nearby communities, and local wildlife, which is something residents pride themselves on. Ms. Twente said that air pollution is one of the most acute concerns with the diesel backup generators emitting hazardous pollutants and fine particulate matter, increasing the rate of respiratory diseases, cardiovascular conditions, and elevating the cancer risk in nearby communities. She said a recent model indicated that the data centers in the US, in 2030 could lead to 1,300 deaths annually resulting in a public health burden of more than \$20 billion. The water used for cooling from water supplies, creating additional challenges, taking water from potable sources and creating water scarcity. She said those in support of data centers state it will bring economic benefit, which is true to a very select few, but to general population and community that is affected by the data center, there is no economic benefit. Unless data can be shown there is an economic benefit for everyone that goes along with the harm to them and their children, she cannot support it.

Ms. Aimee Morris, 26170 W. 199th Street, Gardner, KS, address the Commission. She said this conversation was just had in Spring Hill and Gardner, and now the residents are coming to Edgerton to speak. She believes that Edgerton as a whole knows that the warehouses are being used for warehouse purposes, so changing the use of the plat to a data center is disingenuous to the community saying this was going to happen. Within five (5) miles of this data center, there are ten (10) schools, 6,200 students with 3,100 under the age of 12. Many people have mentioned the health effects on those students. She said with the closed-loop cooling system, there are chemicals that will enter the air and the water in those systems does not stay in the closed-loop. She said she has passed those studies onto the Commission. She claimed that the water does not get recovered once poisoned and gets put into the drinking water. That is one of the reasons why she is there, she does not want that in her drinking water, nor does she want her kids bathing in it. Ms. Morris said she has heard the proposal for a drainage easement. She asked why a drainage easement would be needed if they were not draining the water. She proposes a third-party environmental study saying where the forever-chemicals that are meant to keep the closed-loop pipes clean are going and show what the environmental effects it will have. Ms. Morris stated that it was brought up as to how much water was going to be used daily. The area is set for drought in 2026, so if we want to use our water moving forward want to keep data centers cool instead of keeping citizens able to drink and water their gardens, then put in a data center, but she is not for it. Ms. Morris said the closed-loop systems provide a heat island within five (5) to ten (10) miles of them, meaning people will have increased electrical bills because the air conditioning will have to work harder. She wanted to know if the applicant will be subsidizing their own substation or if they will be straining everyone else's grid, both financially and practically by increasing bills or rolling blackouts and will electrical allotments be dulled out by AI or by humans. She said the parent company of DAMAC is in Dubai and is in international litigation and asked if they want to sell their property to them.

Mr. Jason Sowers, 19911 Pepper Tree Lane, Edgerton, KS, stood before the Commission. He said he agrees with many of the comments that have been made, specifically the moratorium to study data centers and their effects along with studies on wastewater. He said the applicant is claiming the closed-loop cooling system will have near zero usage. This phrase is narrow and potentially misleading as there are regular blowdowns in closed-loop systems to remove

water with concentrated minerals, scale, and buildup by electrical growth. He wondered if a chemical analysis of what this proposed well done water has been provided to the City's wastewater treatment. They cannot risk the introduction of chemically treated discharge into the local infrastructure or ground water under the guise of a sustainable system. The other area of concern for him is electrical rates. Data centers are among most energy intensive structures on earth. While DAMAC is funding the switching station, the sheer magnitude of their regional draw will require infrastructure upgrades by Evergy. Mr. Sowers said that Evergy claims that data centers will pay 20% more than an existing customer. However, there has been no mention of whether they are going to hold firm on the base rate that 20% increase will be applied to. He said that history has shown that the costs are passed on to general rate payer. He said the most concerning is the economic tradeoff. This facility has a massive footprint and consumes many public resources, but in his experience, it will yield 20 long-term jobs. He said traditional logistics and manufacturing hubs provide hundreds of opportunities in the workforce; data centers are essentially a dark building with a collection of servers, a skeleton crew of security and minimal Information Technology (IT) staff. This results in greater than 50% profit margins for the companies. DAMAC is asking the City to facilitate a project that will offer millions in profit for their company while offering a few dozen jobs. He said the neighbors are taking all of the environmental risks, while they take all of the profits. Tax abatements and other incentives exacerbate this problem, as that is money that should be going to schools, fire stations, municipalities, and others while most go out of state or out of the country. He wants to know what the maximum buildout in terms of megawatts is and what other buildings is are they looking to add.

Ms. Robyn Harris, 34117 W. 263rd Street, Paola, KS, addressed the Commission. She inquired as to where Mayor Donald Roberts was. She said that he is smarter than Gardner by taking the intermodal. She explained that she lives just west of Hillsdale Lake and has done her research. She said that we need to ask ourselves why all of these hyper data centers are needed. She inquired if the data centers will be used for surveillance and control. The United States has the most with 4,000 to 5,000. She said she found an article that said Meta is going to cut ten percent (10%) of their workforce in an AI push. She said layoffs from one company is not good for anybody. She said if anyone who states a data center is bringing jobs in is lying. The layoffs effects 8,000 employees and Meta is to close 6,000 open roles as they focus on AI. She said her daughter will be losing her job and that can't be the only one. She said the decisions we make affect a lot of people. She said she understands that the City needs money, but when you want a business to come in, the jobs it brings in should be considered too. That brings in income and people buying homes.

Chairperson Mathos requested a motion to close the public hearing. A gentleman in the audience asked if the full time had elapsed and stated there were people who entered the meeting after him that had a chance to speak while he did not. Ms. Beth Linn, City Administrator, stated there are two (2) public hearings and this was the first one. The gentleman interjected by stating he was handed a signup list by a City employee. Ms. Vaughn stated that is all that who signed up to speak during the public hearing for the Preliminary Plat and there are people signed up for the Final Site Plan, which the public hearing has not happened for yet. The gentleman stated he does not know which one he signed up for. Ms. Linn stated that they can check the list of names to ensure if he is concerned about it. The gentleman stated his concern is that he was told he would be able to speak and he has not been given that opportunity. Ms. Linn explained there is a second public hearing this evening

that he will be able to speak at. The gentleman understood and thanked Ms. Linn for her explanation.

Commissioner Soemer moved to close the public hearing. The motion was seconded by Commissioner Little. The public hearing for Application PP2026-0001, Preliminary Plat for Edgerton Project was closed at 8:04, 4-0.

Chairperson Mathos requested that the applicant address the public comments.

Mr. Skidmore addressed the Commission. He said with the Preliminary Plat they are proposing to combine the three (3) lots into one (1) and have no additional responses at this time.

Chairperson Mathos asked City staff to respond to the public comments.

Mr. Moore stated that a moratorium would need to be action by the Governing Body. The Commission cannot enact one in their roles when considering a Preliminary Plat or Final Site Plan application. The use of the property can be contemplated during a Preliminary Plat. As identified in the Staff Report, the proposed use of a data center is permitted use by right in the L-P District which this Preliminary Plat does not change. Mr. Moore said there was a comment regarding the drainage easement. He explained that the drainage easement is intended for existing stormwater runoff from the site and not for detention. It is not intended for any new offsite flow from any water discharge on this property. Any water that is collected on the site will be diverted to a private stormwater sewer system that would not be included in the drainage easement. Mr. Moore explained any questions related to the number of buildings and noise mitigation will be addressed in the Final Site Plan.

Commissioner Soemer stated his questions will wait for the Final Site Plan.

Commissioner Little said he has no questions about the Preliminary Plat.

Commissioner Draskovich said the applicant is requesting all three (3) lots become one (1) and understands the request.

Commissioner Draskovich moved to approve with the stipulations outlined by City staff Application PP2026-0001, Preliminary Plat for Edgerton Project located at 31800 W. 196th Street. Commissioner Soemer seconded the motion. Application PP2026-0001 was approved, 4-0.

7. FSP2026-0002: FINAL SITE PLAN FOR EDGERTON PROJECT LOCATED AT 31800 W. 196TH STREET

Chairperson Mathos requested Mr. Luckman explain what a Final Site Plan application is and what the application does as part of the overall development process.

Mr. Luckman stated this item is similar to the previous item as it is not zoning decision with the Golden criteria or other factors. He explained this application is for a Site Plan and there are no statutory requirements for Site Plans generally, so this application is controlled by the City code and UDC. The restrictions are only towards reasonableness of their decisions. This

means the Commissioners have to have a basis one way or the other and express that reason. The Commissioners should have reviewed the UDC which has specific requirements for Site Plans that the application must be compliant with. The Commission can review those and determine whether or not those standards have been met. This is not an opportunity for zoning concerns to come up, but if there are specific things about the Site Plan, those items can be addressed. Mr. Luckman said that a reason for denial must be provided per the UDC and the Commissioner will need to establish their reasons.

Chairperson Mathos asked the applicant to present their application.

Mr. Skidmore stood before the Commission. He stated there are a few items with the proposed development plan that he wanted to cover. He said it is an existing building and per the previous agenda item, they will be combining with other parcels to be under one ownership. The building is roughly 380,000 square feet and is located at 31800 W. 196th Street.

Mr. Skidmore wanted to discuss the site access and circulation within the site. There are two (2) access points currently. One (1) in southwest corner of the property, at the west end of the cul-de-sac, and one (1) shared access point on the southeast corner that is shared with property to the east. The proposal is to maintain those access points with no additional or closure of access points. The entrances will be gated and secured. The main entrance will be the western access point. Deliveries and anyone entering the site will go through a security check point and proceed along the south side of the building along W. 196th Street. The site circulation will be in a counterclockwise direction around the building and leave through the same access point on the southwest corner of the site.

Mr. Skidmore explained there are several changes to the building that are proposed. There are currently dock doors on the east and west façades of the building that were part of the previous use. Many of the dock doors will be closed off with compatible materials to match the building. Generator pods will be added to the northeast, southeast, southwest, and northwest corners along the east and west façades of the building. The pods will be screened with a wall that will be architecturally compatible with the existing building. Two (2) additional electrical intake buildings on northeast and northwest corners are proposed. Each building is just over 2,000 square feet. A new guard house would be constructed on the southwest corner near the secure entrance with the footprint being less than 1,000 square feet. Overall, there is less than 5,000 square feet of new buildings proposed.

Mr. Skidmore said the landscaping will be brought up to the current standards in the UDC. Buffering will be included along the west frontage of the property that is adjacent to the Johnson County Rural (RUR) zoned parcel. Buffers will be provided along each side of the electrical infrastructure in the substation and switching station with evergreen trees. He explained the site will be surrounded by a ten (10) foot high, steel, impact security fence. Gates will also be at both entrances with controlled access through security operations.

Mr. Skidmore stated the existing development drainage has been accommodated by using a regional detention basin that is northeast of the subject property. The proposed redevelopment of the property is accommodated by that basin as well. The electrical substation and switching station will require additional drainage. A basin will be installed to the north of that area prior to the water entering the tributary to meet the City's guidelines.

He explained the current public water and sanitary sewer utilities onsite are adequate to service the facility. No public improvement or upgrades are needed for water or sanitary sewer. There are electrical infrastructure upgrades that are being brought in and paid for by the developer in agreement with Evergy to supply adequate power to the facility.

Mr. Skidmore said there will be exterior lighting at the facility. A photometric plan was submitted, and they are working with City staff to bring that into compliance with the UDC. This will include a footcandle reading of zero at the property lines. This will eliminate any lighting spilling onto adjacent properties. He said the L-P bulk zoning regulations are being met. All of the requirements of building setbacks, coverage, height, separations, and site coverage are being met and there are no deviations from the bulk regulations associated with the L-P District proposed.

Chairperson Mathos requested City staff present the staff report and review of the application.

Mr. Zachary Moore, Development Services Director, addressed the Commission. He explained that City staff receives the application for a Final Site Plan from the property owner or their applicant and reviews the submitted documents against all applicable City codes. He said for this Final Site Plan application, Section 5.2, which has the zoning requirements for the L-P District, and Article 10, which outlines the requirements for all Site Plans, are used to review the application. City staff will also look at additional plans, studies, and documents approved by the Governing Body that will have an impact on the application. Based on the review of the documents against all codes, studies, and documents, City staff will make a recommendation on the application. The recommendation is found inside the published packet.

Mr. Moore stated that this application is for a Final Site Plan for 53.79 acres to be in one (1) lot located at 31800 W. 196th Street. He explained the application is to refit an existing 378,038 square foot warehouse for use of data center, which is a use that is permitted by right in the L-P zoning district. The proposed Final Site Plan does include two (2) new medium voltage intake buildings, each being just over 2,000 square feet in size, a new guard shack, an electrical substation and an Evergy switching station. Generators, transformers, and other mechanical and electrical equipment that is proposed to be in four (4) pods with two (2) being on the east and two (2) being on the west sides of the building. The pods will all be behind concrete, screening walls with louvers.

Mr. Moore explained that the property is currently three (3) parcels. The currently developed parcel was annexed into the City in March of 2014 and was later rezoned to the L-P District in December of 2017. He said the Final Plat for the parcel was approved in 2016 and recorded in 2017, along with two (2) parcels to the east. In April of 2016, a Final Site Plan was approved, and the parcel is currently developed under that Final Site Plan with the existing warehouse. The two (2) parcels to the north of the currently developed parcel were both annexed in August of 2018 and rezoned to the L-P District in October of 2018.

Mr. Moore stated the proposed use of a new data center is a use permitted by right. The proposal either meets or exceeds the L-P District regulations that are governed by the City's UDC. That includes the bulk regulations such as the minimum open space, which is 50% for

L-P zoned properties. With all of the proposed property combined, the applicant would have just over 67% open space, exceeding the requirement. The maximum building height in the L-P District is 110 feet, and the applicant is compliant with that requirement as the existing warehouse, which is the tallest at 46 feet in height. He said the UDC requires a Floor Area Ratio (FAR) of three (3) to one (1). The applicant has a proposed FAR of 0.16 to one (1), which is less than the maximum allowed. The UDC allows for a maximum building coverage of 50% and the applicant proposes total building coverage of 16.34%, meeting the requirement. Mr. Moore stated the setbacks for the L-P District are 50 feet for the front yard, and 25 feet for the sides and rear yard setbacks. The closest building to the front yard setback is the guard shack, which is approximately 95 feet from the property line. The buildings will be 45 feet from the eastern property line and 110 feet from the west side of the property. The final bulk regulation is building separation. The UDC requires a minimum of 20 feet between buildings. The closest buildings to one another and the existing warehouse and the medium voltage intake buildings which are about 38 feet apart. The proposal is compliant with the bulk regulations as presented.

Mr. Moore stated that there are no proposed changes to the existing warehouse in terms of architectural design. The warehouse may remain as it was approved under the previously approved Final Site Plan. The three (3) new proposed buildings are smaller in size than what the UDC requires for vertical or horizontal articulation, so none is needed for those buildings. The new buildings are compliant with the color palette and building materials as outlined in the UDC. He explained that the UDC does require that all rooftop mounted equipment be screened from public view by the building parapet or other architectural designs. This will also be included as a stipulation for any new rooftop mounted equipment.

Mr. Moore highlighted that the existing access points are to remain and will be gated. There is an access point on the southwest corner of the property and a cross access to the property to the east with a gate. The applicant is proposing a private drive from the existing developed area to the substation and switching station to the north. An access drive is also proposed from W. 191st Street where there is an existing curb cut to the parcels with the new substation and switching station. The applicant would be required to build the private drive from W. 191st Street to that area. Mr. Moore said the applicant is proposing a reduction in the parking from 316 passenger vehicle spaces to 153 total parking spaces. The applicant has indicated that there would be a maximum of 30 employees at one given time with minimal visits from the public. City staff finds that the reduction in the parking spaces is sufficient for the proposed use. A loading dock will remain on the west side of the building and that will meet the requirements of loading dock areas for buildings of this size. He said there is sufficient queuing space for vehicles as any vehicles that need access to the site will be pre-authorized.

Mr. Moore informed the Commission that gravel is proposed for the substation and switching station area. While the City typically requires a finished surface, City staff consulted third-party reviewers who informed staff that gravel is the industry standard for these types of areas for safety reasons. Therefore, City staff is supportive of the use of gravel in the substation and switching station yards.

Mr. Moore stated the proposed landscaping plan shows the removal of 50 existing trees and the installation of 79 new trees on the property. The new trees are primarily shown on the western property line, where 24 deciduous trees and 200 new shrubs are proposed to fulfill

the UDC requirements. Additionally, 55 new evergreen trees are proposed on the east and west sides of the substation and switching station areas to provide screening of the electrical equipment. The existing vegetation to the north of the electrical equipment will remain, which will provide adequate screening as well. A decorative fence that is ten (10) feet in height is included on the Final Site Plan for security. The fence does meet the UDC requirements for height and material.

Mr. Moore said the applicant anticipates approximately 20 passenger vehicle trips per day with no customer-facing traffic. He said a stormwater management study and plan has been submitted and reviewed by the City Engineer. There are comments that still need to be addressed, and the applicant is aware that prior to the issuance of a building permit, all comments must be addressed. This is included as a stipulation of City staff recommendation. The future access road from W. 191st Street would cross the floodway area and will require a bridge. Specifications of the bridge must be provided for review, a floodplain development permit, with a no-rise certification, will be required, as will state and federal permits. The applicant is aware of those requirements as well.

Mr. Moore explained that the UDC requires footcandle reading, as measured five (5) feet above grade, to be 0.0 when adjacent to residential properties and 0.2 footcandles when adjacent to nonresidential properties. The submitted photometric plan for existing warehouse meets these requirements. A second photometric plan for the substation and switching yards has been provided but is not compliant with the UDC. City staff has included the stipulation that the second photometric plan must be in compliance with the UDC prior to the issuance of a building permit. The applicant is aware of that stipulation and is in agreement with it.

Mr. Moore stated the UDC requires all ground or roof mounted equipment to be screened from public view, which is defined as view from public right-of-way or adjacent property. The applicant shows four (4) areas of ground mounted equipment, two (2) on the east and two (2) on the west side of the building. Each area is proposed to consist of 15 generators with the related equipment for those generators to remain functional. The equipment will sit behind a screen wall that must be the same height as the equipment at a minimum and must remain screened at all times. If any portion of the equipment can be viewed as outlined in the UDC, then the applicant must address it.

Mr. Moore said that City staff recommends approval of Final Site Plan Application FSP2026-0002, Final Site Plan Application for Edgerton Data Center with the following stipulations:

1. Applicant/Owner Obligation. The site plan, a scale map of proposed buildings, structures, parking areas, easements, roads, and other city requirements (landscaping/berm plan, lighting plan) used in physical development, when approved by the Planning Commission shall create an enforceable obligation to build and develop in accordance with all specifications and notations contained in the site plan instrument. The applicant prior to the issuance of any development permit shall sign all site plans. A Final Site Plan filed for record shall indicate that the applicant shall perform all obligations and requirements contained therein.
2. Prior to the certification of the Final Site Plan by the Zoning Administrator and the issuance of a building permit for exterior site improvements on the subject property, the following must occur:

- a. A photometric plan for the substation must be submitted and approved by the Zoning Administrator.
 - b. The stormwater management report must be revised by the Applicant and approved by the City Engineer.
 - c. The proper floodplain and floodway permits must be obtained from all applicable jurisdictions and the details for the required bridge must be provided.
3. All outdoor mechanical equipment must be fully screened from public view as defined in the UDC. If, following construction of the improvements indicated on the Final Site Plan, it is found in the built environment that mechanical equipment is not adequately screened upon inspection by the Zoning Administrator or their designee, the Applicant will be required to adequately screen said equipment.

Chairperson Mathos reiterated the rules and requirements of the public hearing.

Chairperson Mathos opened the public hearing at 8:33 PM. She stated that prior to calling the first speaker up, City staff will read the names and addresses of written comments submitted to the City preceding the meeting. City staff will indicate if the comments were in support, opposition, or neutral in nature.

Ms. Vaughn explained that it is the same list read prior to the previous public hearing.

Mr. Oltman approached the Commission. He said he is speaking in support of the Final Site Plan for the project that is looking to locate within LPKC. He requested that the Commissioners separate the facts from the fiction. He said that it is fiction that the project will use millions of gallons of water and drain the water supply. There have been technological advances at a rapid pace for cooling systems in the last 24 months. The project will use a closed-loop cooling system that will require a small fill at the beginning of use then will not need substantial ongoing access to water. Once the facility is operational, the water use will be less than a standard warehouse. He claimed that it is fiction that electrical bills will go sky-high and regular customers are going to have to pay for the upgrades. He said the fact is in 2025 the Kansas Corporation Commission, which is the agency that regulates utility and energy services in Kansas, approved a new large-load service agreement specifically designed to protect regular electrical customers from new massive electrical customers. This agreement specifically states the new high-load customers must pay for upgrades needed for their project, they must sign long-term contracts, pay for a minimum threshold of power even if it is not being used, and pay up to 20% more than standard rates for regular customers specifically protecting regular customers from increased rates and upgrades charges from these types of projects. Mr. Oltman said it is fiction that this project will not create any jobs. He contended that the facility would create high paying, quality jobs that will be available to the residents of Edgerton and surrounding communities. He continued by stating that these jobs will have higher wages than typically seen at normal warehouse environments with most positions averaging over six (6) figures a year. The facility will provide no benefit for the Edgerton community - fiction. He stated the fact is the facility will provide considerable benefits to the Edgerton community. In addition to the high paying jobs mentioned, this facility will generate a significant amount of sales tax revenue for the Edgerton community. With the recent passage of the new community sales tax dedicated solely to street and stormwater projects, those dollars will accelerate much needed projects in areas specifically

like the horseshoe. He hoped the Commissioners could objectively consider the request before them this evening and accept the facts and reject the fictional narrative being established.

As the audience began to jeer, Chairperson Mathos requested that members of the audience act with civility and respect towards all speakers. A gentleman asked that he be allowed to speak when Mr. Oltman had been allowed to speak twice. Ms. Linn stated that everyone was offered a chance to speak during either public hearing or both if they wish.

Mr. LaFalce addressed the Commission. He said he is a 30-year resident of Edgerton. He said gets the perception based on their body language that they have already made a decision. He said that Christ was sold out for 30 pieces and he wants to know what their pass was. He said they are there to represent the community and that if they pursue this project then they need to resign in mass right now. He said they will be removed from office through a recall. He stated he will have his friends at the Department of Justice to follow the money.

Ms. Shaunacee Wilkinson, 105 E. McDonald Street, Edgerton, KS, spoke before the Commission. She said she was born and raised in Edgerton and now her daughter goes to Edgerton Elementary and Ms. Wilkinson serves on the advisory committee as the school district reworks the district's boundaries. Her current role is to encourage people to come to Edgerton. There is push back on students who don't want to come to Edgerton. Her role is to show that Edgerton is safe, clean, and a place to be proud of. She said Edgerton has had an edge of the County reputation and it is not seen as being in Johnson County. She has had to fight that reputation having grown up here. They have been changing that reputation with the projects at the playground, Big Bull Creek Park, new sidewalks, and Greenspace building are making the area more welcoming, more walkable and a place they can be proud of. She said the new sidewalk and curb on 2nd Street are her new joy. She stated she is concerned about the data center as it feels misaligned with the direction they are wanting to go. While the project does fill a current vacant building, it brings a different impact than what was there before. Ms. Wilkinson shared she had a chance to speak with members of the project team. She stated many of them grew up and currently live in larger metropolitan areas such as New York, Long Island, and Atlanta. She said they don't understand how connected a small community is and why they are potentially upset with this change. She requested the development team provide comparable communities where data centers had been built. Several members of the team had no comment while Chelsea provided two (2) communities. Ms. Wilkinson recommended that research be done as to how Red Oak, Texas and Midlothian, Texas are doing after the data center arrived. She said it is not just about development but the long-term impact as the facilities run 24/7, have continuous noise, use lots of energy, and significant water use. The long-term impacts on the environment and health are not fully understood. They already know that chronic industrial noise and infrastructure strain can sleep, stress, and overall quality of life. She said her parents live near the train tracks and closer to the quarry than most, and have had the firsthand effect on their sleep, noise pollution, and infrastructure challenges. She does not believe small towns like Edgerton and the community should not take any more risks and once it is done it can't be undone.

Mr. Don Vestal, 612 W. Hulett Street, Edgerton, KS approached the Commission. He apologized for his outbursts earlier; he just wanted to make sure he was given the chance to speak. He said he is 72 years old and has lived in Edgerton for the last 25 years. He moved to Edgerton to retire in peace. He was an IBEW electrician for 42 years and he might not have

worked at a data center; he has worked on all of the equipment that is in a data center. Unless the applicant is willing to pay for the entire cost for the power distribution improvements, he is against it because it will fall back on normal customers with rate increases. He is not sure on the estimated water usage, but they say it is a closed-loop system and that is a lie. The water has to be cooled and is done by industrial chillers. The chillers require that chemicals be injected into the water to prevent rust and corrosion. Those chemicals cannot be treated by a common wastewater facility and have to be handled as hazardous waste. He has experience with industrial chillers and had to do it when he worked on the railroad. If the Commission does not believe him, then they need to watch the movie, Erin Brockovich. He said he was raised for the first 20 years of his life in a town 13 miles from Hinkley, California. That town, 40 years later, is a complete dead zone because the civic, gas, and electric companies released these anticorrosive, rust preventative chemicals into a cooling can and was absorbed into the water system. This turned the entire town and surrounding areas into a dead zone. Mr. Vestal stated the last item he wants to address is taxes. He said he always pays his taxes, and he wants their full bill paid without any abatements or deferments. He claimed that the tax money belongs to us and not them. He said they can bring their company in as he is not against improvement or advancements, but he is against people who don't want to do their own fair share. He said the Commissioners stood up and said the Pledge of Allegiance to the Flag, which made his heart happy. He said the best thing about this county is that if the representatives don't represent the people, you can get rid of them. He said you can cut off the head of the snake and get a new group of people in.

Ms. Olivia Baken, 217 W. McDonald Street, Edgerton, KS, spoke before the Commission. She said she moved to Edgerton in 2021 and loves this town and loved that it was a small town with no facilities using all of their water. She said her water bill has gone up and it is concerning. She said she has done some research, and it showed that in five (5) years, water bills will increase 24% on average in cities with data centers. She said she is highly concerned that this topic was brought before the Commission when it has been in the works since November. She said they had a lot of time to plan everything, what was going to be happening and how to present it. The town was not able to seek out a moratorium to find out more information. She said they do not want a data center in their community. Ms. Baken said their salaries are paid through their taxes. She said the Commission works for the residents and the residents do not work for the Commission. She said that they are the people that speak and what the Commission is to do is act on what they request. She said it is clear that the town does not want the data center and she has not spoken to one person who wants it. She wants to know why it is so easy for the Commission to not oppose the idea. She wants to know all of the closed-door deals. She said this project came to Edgerton after Gardner refused any incentives. She inquired about what incentives are being offered. The applicant came to speak as to how great the data center will be and how unharmed it will be. She said her research shows that there are pollutants in the water and forever chemicals that leak into the water source and into the soil which poses long-term environmental risks.

Commissioner Soemer moved to close the public hearing. The motion was seconded by Commissioner Little. The public hearing for Application FSP2026-0002, Final Site Plan for Edgerton Project was closed at 8:49, 4-0.

Chairperson Mathos requested that the applicant address the public comments.

Mr. Skidmore stood before the Commission. He said in regard to the Site Plan approval process that is being considered, he emphasized that they are meeting the bulk regulations of the L-P District. The public water supply and sanitary sewer is in place that serves the existing building and adequate to service the purposed facility. The additional electrical components are being brought in as part of the development.

Ms. Kulhanek thanked the Commission and stated that this project is not affiliated with other developments in other cities.

Chairperson Mathos requested City staff respond to the public comments.

Ms. Linn stated there are a few points of clarification that need to be made. She explained this project is not associated with other projects. This is not the company that had a proposal in Gardner and is not the company that had a proposal in Spring Hill. In anticipation of questions about data centers that are not typically handled during the Site Plan phase of development as explained by the City Attorney and the City's role in the application, a lot of information was included in the published packet. It included information from other sources from Evergy, the DAMAC Digital Team, she would recommend those materials be referenced. Questions like energy usage and things like that are outside the City's role for review. She recognizes there are other questions out there.

Commissioner Draskovich inquired if a decibel reading could be provided as to what the equipment will put out and what could be heard nearby. He also wanted to know how far the noise would travel. Ms. Kulhanek replied that they will be in compliance with the zoning code and their data is based on industry data and specifications from the manufacturers' equipment. Commissioner Draskovich asked if any numerical data would be provided at this time. Chairperson Mathos stated Ms. Kulhanek stated that is correct to ensure Commissioner Draskovich heard the response. Commissioner Draskovich said that no actual data was going to be provided. He said that the applicant is not providing a number, so he asked how will be compliant with the code and inquired if they knew what the code required. The applicant stated that they are continuing to work with acousticians on applying the requirements of the code and not only meeting those requirements, but also exceeding those numbers, but it is a process. Commissioner Draskovich stated that his question was not answered and he is requesting a set number because the applicant should have some sort of reading as it pertains to noise pollution and they need to provide data. He said the applicant needs to understand that they are on the back end and trying to dig themselves out of a hole and bringing actual data would be a good thing. If they are unable to provide a number, then he has all of the information that he needs. The applicant responded that they have reviewed the code as it relates to noise emanation and it is essentially protected based on distance to residential properties and the impact of any industrial noise on the noise level within the city. They continued that they are confident they will be lower than what the code allows and stated that the code does not provide a number. The audience demanded they provide a number. Commissioner Draskovich requested civility so they can get the information. He said they are providing information on residential, and he asked if they were aware of the requirements for commercial properties. The applicant responded that they are confident that they will be under the way the code addresses noise emanation in both residential and commercial and how it relates to impact on residential areas. He said the nearest residence is over 1,000 feet away. A member of the audience asked if the noise level will be met at all times. The applicant

responded in the affirmative. Commissioner Draskovich stated that the nearest commercial property is 134 feet away. The applicant stated that is understood. Commissioner Draskovich said that there will be people working in nearby areas that will be impacted by the noise level. The applicant said they have evaluated the code and with respect to everything else that is being done, they will follow the City's requirements and is confident that the project will be under the noise ordinance allowance.

Commissioner Draskovich asked if any of the floor drains will be connected to the City sanitary sewer where the data center itself will be located. Mr. Skidmore answered that the floor drains will not be connected to sanitary sewer system. Commissioner Draskovich inquired if there are currently any floor drains that are connected to the City's sanitary sewer. He asks this because the closed-loop system will have a lot of lines and the taxpayers need to be protected from risks. He understands that is not really in the scope of a Final Site Plan, but he has questions about protection for any spills entering the stormwater or sanitary sewer system. Mr. Skidmore responded that there are existing floor drains in the building, but with the repurposing of the building, those will not discharge into the public sanitary sewer system. Commissioner Draskovich asked if they will be closed off. Mr. Skidmore stated that is correct.

Commissioner Draskovich inquired about how many facilities DAMAC has currently in operation that are roughly the size of this proposal. Ms. Kulhanek replied that DAMAC has many centers around the world in southeast Asia and Europe but no current data centers in the US. Commissioner Draskovich asked if any of the existing centers were the same size as this one. Ms. Kulhanek stated that projects vary in size. Commissioner Draskovich asked what kind of cooling system the centers use. Ms. Kulhanek answered that they utilize a variety of cooling technology in different projects, and she does not believe there is an apples-to-apples comparison that could be made. Commissioner Draskovich said if there are closed-loop systems currently being used, the water usage from that facility could be provided to give an estimate as to what this center could use. He said that providing data is important and good when presenting the application and asked if they were willing to provide that information. Ms. Kulhanek replied that is not in the scope of this application.

Commissioner Draskovich if the property owner was planning any expansion in the future. He also asked that if the closed-loop system doesn't work and isn't as efficient, if they would change and go to evaporative cooling. Ms. Kulhanek replied that is not in the scope of this application.

Commissioner Little stated a stormwater survey and study was submitted. The Army of Corps Engineers started a study for the data center impact that was recently withdrawn from Gardner. He said he would like to see that report and what the impacts of a project like this would have as it would be the first in the area. He wants to know what the watershed can handle, especially since he foresees more coming in the future. Ms. Linn stated she is not familiar with that particular study, but she knows the Army Corps of Engineers were working with the water office on a wastewater study. Commissioner Little stated it was a wastewater runoff study. Ms. Linn explained that they study was looking at wastewater and how to handle wastewater in this area and is not related to a particular industry as it is aimed at finding a long-term solution on how to handle wastewater in the watershed.

Commissioner Little inquired as to why a Preliminary Site Plan was not concerned for this project. Mr. Moore replied that the UDC allows applicants to submit a Final Site Plan application without a Preliminary Site Plan application being submitted if all of the applicable information can be provided. This allows for the public hearing to be held at either the Preliminary or Final Site Plan so there is one (1) public hearing for the proposal regardless of the application. Commissioner Little stated that the Commission has considered Preliminary Site Plans in the past while other projects have gone straight to a Final Site Plan. Ms. Linn explained that with an existing building, it is not unusual for an applicant to submit for a Final Site Plan and not go through a Preliminary Site Plan application but still has the requirement of a public hearing being held. She added that as the City Attorney explained, a public hearing at the Site Plan phase of development is not required by the state statute, but the UDC requires the public hearing as a form of transparency.

Chairperson Mathos stated that she is in healthcare and testing of the generators is done. The applicant will be testing their generators. She understands that this will be the first data center in the US for the applicant, but she inquired as to how often the generators are tested. Ms. Kulhanek replied that the generators will be tested monthly and the run time limited by EPA to about one (1) hour per month per generator. Chairperson Mathos asked if the generators will run at the same time or will they be done in succession one at a time. Mr. David Varghese, DAMAC Digital, answered that they will test one (1) line-up at a time and there are typically six (6) generators in a line-up. He added that depending on how the testing is to be done, multiple line-ups can be done at once. He said testing will be done in a way that makes sense for noise regulations to be met. Ms. Kulhanek said the testing would be done during business hours at a scheduled time. Chairperson Mathos stated that the generators are to be screened but there is nothing over the generators. She asked what the air quality is would be like around the generators. Ms. Kulhanek there are certain emissions with diesel gas generators which are typical with industry standards, but they are going to follow EPA standards. There are studies in review of the operational run times and actual emission calculations, so they do not have that information available with them this evening. Chairperson Mathos clarified that the data is in review with the applicant's team. Ms. Kulhanek replied that the EPA has the data. Chairperson Mathos asked if it would be information that could be provided prior to occupying the building. Mr. Varghese stated that is possible and the generators cannot be installed without EPA and state approval. A permit must be provided prior to the installation of the generators and other auxiliary equipment. Ms. Linn stated just like with other applications such as land disturbance, the applicant must submit information to the Kansas Department of Health and Environment (KDHE), and once KDHE has approved the information, then the City can review the documents under our code requirements. She said for generators, the information must be submitted to the EPA, which is administrated by KDHE in the state of Kansas, KDHE reviews the documents and issues a permit. All of that needs to be in hand prior to any Certificate of Occupancy being issued. Mr. Varghese said these permits are not new under the EPA and Clean Air Act, which has been in place since the 1960s and is regulated by the state and EPA. They have to follow those guidelines or they don't get the permits. Chairperson Mathos stated that 60 generators is a lot and wanted to make sure there are other checklists in place.

Commissioner Draskovich stated that it is most likely the generators are generally set. He said they cannot act like they don't have the information and data. The generators are most likely already manufactured and be delivered as a whole unit. He again requested the decibel

readings of those generators put out during testing. Ms. Kulhanek replied that they do have data sheets as it relates to each manufacturing specification, however there are components of site design that will happen during the final phases of the project that will take into account other noise attenuation, positioning, and screening and other components of that design. Mr. Varghese said the reason why they are not providing decibels in this scenario is this is the initial Site Plan submission. They are still finalizing equipment selections and providing those readings to the acoustical engineers to make sure that it is adequate to the community and to the surrounding neighborhoods. They are committed to making it right to the community and that is why they are confident that they will make it work. They still have to go through those equipment selections and finalize it and run it through the studies to ensure it meets the codes and regulations. Commissioner Draskovich stated that if the generators are going to be brought to the table, then actually bring it to the table because the Commission and community cannot come here with hopes and dreams, they are not coming to the table with unicorn farts. If an applicant is going to come before the Commission and request a Final Site Plan, then they should know what equipment they will be installing so they can provide all of the information. Stating they are still finalizing equipment and still finalizing things with acoustical engineers is not ideal when there are concerns about noise pollution.

Chairperson Mathos requested clarification and reiteration as to what they are voting on. Mr. Luckman explained that there are three (3) motions available. They are to approve, deny with reason or table with direction. He said that UDC Subsection 10.1.H has the standards to approval. This section is used for approving or disapproving a site plan. There are eight (8) factors to look at. The best thing to do if they are looking to disapprove the site plan, then list what of those factors has not been met and need to be addressed. Tabling for direction is more open because this is a process, then they can request additional information. Mr. Luckman said the only limitation is that the request has to be reasonable and there has to be a standard that applies that the information will help satisfy. He said for example there is nothing about the rate charged by Evergy, so asking for that information is not within the standards and would not be reasonable.

Mr. Sowers interjected that Mr. Moore had not completely answered his questions. Mr. Moore responded that he thought the questions were answered during the presentation for the Final Site Plan. The questions about maximum number of buildings. The only information City staff has is the number of buildings provided in the application as the existing warehouse and the three (3) proposed buildings. The questions about megawattage would have to be deferred to the applicant.

There was a lot of chatter from the audience and Commissioners. Chairperson Mathos inquired if executive session could be called. Ms. Linn responded that discussion is required to be open to everyone.

Commissioner Draskovich stated that everyone sees where he was going with this. Chairperson Mathos inquired as to where that would fall under those eight (8) factors. Commissioner Draskovich said it will fall under Article 5 in the L-P zoning. Within the warehouse district the purpose is also to limit vibration, noise, smoke, pollution, fire and explosive hazards, glare and yeah, yeah, yeah. That has to be taken into consideration, especially since noise pollution is a pollution that they need to think about. Chairperson Mathos stated that she believes that under Section 5.2, we can ask for additional information if that

is what he is proposing. Commissioner Draskovich said the other thing that they have to consider is that under Conditional Use Permit (CUP) in Article 7, and rock crushing that have been discussed, the reading of 60 decibels in an adjoining residential area or 70 decibels in an adjoining commercial property. The property to the west, just under 135 feet away, will have people working and other people working with people to the east. Chairperson Mathos said this is not a CUP. Commissioner Draskovich stated he understands that.

Commissioner Draskovich stated that pertaining to Article 5 and Article 2, he motions to deny the request for a data center. Mr. Luckman stated that in Subsection 10.1.H, there is no standard for inserting zoning controls in the decision. If there is a factor in Subsection 10.1.H that is lacking, then it could be made for the motion to deny. Chairperson Mathos inquired if additional information could be requested by using another motion. Mr. Luckman stated that if the Commission believes there is additional information needed, then yes. But the UDC does not allow for a reason to deny based on compliance with zoning requirements. It mentions landscaping, the Comprehensive Plan, and other policies, but not noise specifically. Commissioner Draskovich said that under the current zoning in the L-P District, a CUP would be required for a use that spills 70 decibels of noise onto an adjacent commercial property. He is trying to point out that it would be a potential zoning issue, and the Final Site Plan does not adequately address the potential issue. Mr. Luckman asked if Commissioner Draskovich is saying that the use does not fit within the L-P zoning district. Commissioner Draskovich said that the applicant is not bringing any readings and the only information they are providing is that they will try to do better. The only thing the Commission can fall back on is what the area was zoned for previously, which has a decibel reading in writing in the UDC. He inquired if the zoning does not pertain to the Final Site Plan. Mr. Luckman said it pertains to the application but it is not a test or hearing as to whether or not the Final Site Plan fits within the provisions of the zoning district and the public hearing is on if the Final Site Plan meets the standards of approval outlined in the UDC. Commissioner Draskovich stated he understands that but that is also numbered information that is provided in the UDC. Chairperson Mathos stated that under the UDC, they have met the requirements. Mr. Luckman stated that the motion imports standards that the City does not recognize for site plans. Chairperson Mathos said the provisions are not being discussed, but the actual site plan is. Mr. Luckman said that if the property violates the zoning restrictions after construction, then then it will be a code violation, just like any other property. He gave the example that if someone opens a home business and they do not comply with the regulations, it could be shut down.

Mr. Luckman stated there is a motion on the table. Commissioner Draskovich withdrew the motion.

Commissioner Little moved that Application FSP2026-0002 be tabled until the decibel readings requested by Commissioner Draskovich could be provided. The equipment should have been decided as this is a Final Site Plan application. Commissioner Draskovich seconded the motion.

Commissioner Soemer stated that the request is zoning related and inquired if the motion was legitimate per the UDC. Commissioner Little said the application is for a Final Site Plan while the applicant said it is an initial request, so nobody is on the same page. Chairperson Mathos said that it the request is for a Final Site Plan, not a zoning application. Commissioner Little said they were in the initial stages of getting their equipment. Chairperson Mathos said what

is being requested is zoning information, not Final Site Plan related information and she is not sure if it is a legitimate motion. Mr. Luckman said the motion was general, just like the previous motion, and clarity is needed in the motion. He asked if Commissioner Little was requesting that the construction plans be within the decibel levels of that required in the L-P zoning district. He asked what standard was being used. Ms. Linn stated that the standards that Commissioner Draskovich referenced earlier are for a CUP portion of the L-P zoning district and not a standard in the L-P zoning district. Mr. Luckman inquired if there are any decibel standards. Ms. Linn replied that there is not. Mr. Luckman stated that the request for the decibel level would most likely be outside the purview of the Commission.

Commissioner Soemer introduced himself to the audience. He explained that he is a community volunteer and has been paid in the amount of one (1) t-shirt. He said he is not an attorney but has understood where they would end up for the last two (2) hours. They are all uncomfortable with a lot of things, and yet what is before use, even if they feel backed into a corner, they do not have a statute to lean on to deny or table the application. He said that is their role as a Planning Commission and they are not a Governing Body. There was chatter from the audience. Ms. Linn stated it is not a conversation between the audience and Commission. Commissioner Soemer said he is speaking clearly and loudly so all can hear and is speaking to the other commissioners so they, and the audience, understand the position they are in.

Mr. Luckman said there is a motion and second that has been presented and should be voted on. The Commission requested the motion be repeated. Mr. Chris Clinton, Planning and Zoning Coordinator reread the motion as Commissioner Little moved to table Application FSP2026-0002 be tabled until the decibel readings requested by Commissioner Draskovich could be provided. Mr. Luckman said the motion was seconded and there was no clarification of that because it did not meet a standard. The question is before the Chairperson whether the motion and second can be accepted as it is not set to a standard outlined in the Code. Chairperson Mathos stated the motion and second cannot be accepted as it is not based on a standard. Mr. Luckman stated that the motion has been ruled as out of order and the floor is back open.

Commissioner Soemer stated that the statute has them backed into a corner. Chairperson Mathos said that if there is something in the statute that allows the Commission to request additional information, she would be in support of that motion. Ms. Linn stated that the standards have been shared to Commissioner Draskovich's screen as he is joined via videoconference. Chairperson Mathos stated that the application is for a Final Site Plan and there are three (3) options. The Commission can approve it, deny with cause, or table the application requesting additional information within those standards.

Commissioner Draskovich said they are backed into a corner. The Commission is at a slight impasse.

There was chatter from the audience that the Commission is to find a reason not to approve and must listen to its constituents.

Commissioner Draskovich explained they are in a tougher situation because they are not the City Council.

Mr. Luckman stated this is about the rules that they and the City Council create. The reason why the UDC is published is so that anyone can come in and know what the rules are when they submit and the rug will not be pulled out from under them by having additional requirements added. That is not how the law or the system works. There are clear standards to be met and if those standards are met, then the applicant should get the chance to proceed. That is why they are focusing on the standards of approval, this is what is required, not more and certainly not less. If no reason can be found that the standards have not been met, then the application complies.

Commissioner Soemer moved that in the absence of any statute-based denial or statute-based direction given to City staff that application FSP2026-0002 be approved according to City staff direction. Mr. Luckman requested a point of clarification that there is no state statute governing the application, it is all under the city code. Commissioner Soemer stated that is correct. Mr. Clinton stated that the motion on the table is that in the absence of any code section based on denial, the motion to approve the application with the stipulations outlined by City staff. Mr. Luckman informed the Commission that a Commissioner can second a motion and not have to vote to approve the motion and he stated that the Chair can motion as well.

The audience stated that the motion can just die on the table and that the public was invited and public comment is welcomed. Chairperson Mathos stated that public comments can be made during the public hearings.

Commissioner Draskovich inquired if any of the items will go to the Governing Body. Chairperson Mathos said that the Commission is the deciding body. Commissioner Draskovich asked that nothing will be going before the City Council. Ms. Linn stated that a Final Plat must still be submitted, but for a Final Site Plan the Commission is the deciding body. Commissioner Draskovich requested Ms. Linn repeat herself. Ms. Linn stated that for the Final Site Plan, the Commission is the deciding body, but should this application be approved like the Preliminary Plat, the applicant would need to submit a Final Plat application which would have to come before the Commission and City Council without a public hearing.

Mr. Luckman said there is a motion on the table. Chairperson Mathos said that if there is no second, then it will die on the table. Commissioner Draskovich stated that he does not see a choice but to second the motion. Commissioner Draskovich seconded the motion for approval of Application FSP2026-0002. The motion for approval of Application FSP2026-0002 with the stipulations outlined by City staff failed to pass, 2-2 with Commissioners Little and Draskovich voting no.

Mr. Luckman said that if there is a question of the engineering design of the generators, which could include noise levels, Subsection 10.1.H.5 states that "[t]he plan is consistent with good land planning and site engineering design principles." Site design principles may be wide enough for a Commissioner to request those items to satisfy the original questions posed about the generators. Mr. Luckman reminded the Commission, that based on what the applicant says, there is no ultimate zoning standards to apply, the Commission would be just gathering information for their own purposes.

Commissioner Draskovich said that would at least allow the Commission to get the information. He asked if that would fall under Article 5.2. Mr. Moore stated it would be UDC Section 10.1.H.5. Commissioner Draskovich said that would at least allow time to get the proper information.

Commissioner Draskovich moved to table Application FSP2026-0002, Final Site Plan for Edgerton Project located at 31800 W. 196th Street, in regards to UDC Section 10.1.H.5 for more site engineering design principles related to generators and noise pollution. Commissioner Little seconded the motion. Application FSP2026-0002 was tabled, 4-0.

Chairperson Mathos requested City staff outline the next steps in the development process.

Mr. Moore explained that since the application is tabled, it will come again before the Commission and will be for the Final Site Plan only. Ms. Linn added that since the public hearing was held tonight, there will not be an additional public hearing held, it will just be additional information presented to the Commission.

8. Future Meeting Reminders

Chairperson Mathos stated that the next regular sessions are scheduled for June 9, 2026, at 7:00 PM; July 14, 2026, at 7:00 PM; and August 11, 2026, at 7:00 PM.

9. ANNOUNCEMENTS

There were no announcements made.

10. ADJOURN

Commissioner Little moved to adjourn the meeting. Commissioner Soemer seconded the motion. The meeting was adjourned at 9:49 PM, 4-0.

Submitted by Chris Clinton, Planning and Zoning Coordinator

DAMAC public comment for 5/12 meeting @7pm

From Aimee Morris <aimeemorris224@gmail.com>

Date Thu 5/7/2026 9:44 PM

To City Clerk Distribution List <cityclerk@edgertonks.org>



Caution: External (aimeemorris224@gmail.com)

First-Time Sender [Details](#)



[Safe](#) [Spam](#) [Phish](#) [More...](#)

[External Sender]

My family lives in Gardner just over the city line. I am STRONGLY against the development of this data center!

I have recently been put in the position to do significant research on the process of these data centers.

The closed loop cooling systems are full of chemicals that bleed into the air and the water DOES need to be dumped into the community water. The chemicals get into the aquifers and poison them! The water cannot be recovered.

Here is a link to an NIH bulletin that outlines the process of a closed loop system... chemicals used to keep the pipes clean, preventative chemicals, etc. But it also mentions clearly that it is rarely actually closed, and that there is generally about a 25% loss. This loss ends up in the environment, including seeping into the aquifer, running even our wells. Once that is contaminated there is no going back.

https://orf.od.nih.gov/TechnicalResources/Documents/Technical%20Bulletins/23TB/Closed%20Loop%20Water%20Treatment%20-%20August%202023%20Technical%20Bulletin_508.pdf

This particular NIH bulletin discussed all the reasons corrosion in those "closed loop" pipes happens.

https://orf.od.nih.gov/TechnicalResources/Documents/Technical%20Bulletins/25TB/Corrosion%20in%20Closed-Loop%20Water%20Systems%20Part%201%20-%20Understanding%20Corrosion%20-%20May%202025%20TB%20_508.pdf

It is deeply important to my family and your community that we have clean water to drink and bathe in.

This singular issue is one of many that we have seen with these data centers.

Another being that Kansas is set for a drought in 2026! But many of these data centers take water from the environment to get up and running. On top of it they have to flush the system periodically-

generally into the community water, then they have to fill back up again!

If we don't have water to drink, but we are able to have our ai systems up and running what good are we doing?

Many of these closed loop systems put off a significant amount of heat because these servers run so hot. The temperature of these servers are causing "heat islands" that are raising temperatures for up to 6 miles from the data centers! This is not only causing all of wildlife to pay for our mistake of putting these things in, but you could also think of all the air conditioners that will have to run that much harder in order to keep cool- and all the utility bills that will be run up. On top of that the data center will be taking energy from Evergy, maybe they'll subsidize their own sub station, or maybe they won't but it will be putting strain on our grid. Financially and practically. Increasing our bills - likely even worse; rolling black outs etc. — will our electrical allotment be determined by AI systems that we are putting in place here?

These machines are often reaching end of life by the time they're 5-10 years old, and if you've chosen to put this center in, and even expand to other buildings, Edgerton will soon be a wasteland - left with forever chemicals contaminating your environment and families left sick, your energy all sucked dry and building left with useless machines needing upgraded.

As the government that has been put in place to protect your community, PLEASE do just that. Take all this and more into consideration. We will never be able to undo this if you vote yes. Right now, you have the opportunity to keep big data from getting bigger.

Thank you for your time.

Aimee Morris

Gardner Ks

letter of support - DAMAC Digital

From Brian Johanning <brian@superiorbowen.com>
Date Tue 5/12/2026 8:21 AM
To City Clerk Distribution List <cityclerk@edgertonks.org>

 1 attachment (722 KB)
Letter of Support.pdf;



Caution: External (brian@superiorbowen.com)
First-Time Sender [Details](#)



[Safe](#) [Spam](#) [Phish](#) [More...](#)

[External Sender]

Please find attached a letter of support in advance of the Planning Commission meeting tonight.



SUPERIOR BOWEN

*A Legacy Infrastructure
Group Company*

Brian Johanning
Executive Vice President

o 816.298.5560 | m 816.394.0979
brian@superiorbowen.com

520 W. Pennway St., Suite 300
Kansas City, MO 64108
superiorbowen.com



SUPERIOR BOWEN

To Whom It May Concern:

On behalf of Superior Bowen, I am writing in strong support of the proposed Heartland Data Center development and the substantial economic opportunities this project represents for the region.

As a regional leader in asphalt production and heavy civil construction, Superior Bowen understands the scale of infrastructure investment required for modern data center campuses and the meaningful economic impact these projects generate during both construction and long-term operation. Developments of this magnitude create significant demand for local contractors, suppliers, skilled trades, trucking, utilities, and supporting businesses throughout the surrounding community.

Recent large-scale data center investments throughout Missouri and the Midwest have demonstrated the ability to generate hundreds of construction jobs, increase local tax revenues, and attract additional private investment into surrounding communities. Missouri's Department of Economic Development recently announced a \$1.4 billion data center project in Liberty expected to create hundreds of construction jobs and high-paying permanent positions with average wages approaching \$100,000 annually.

Projects like Heartland Data Center also provide critical opportunities for local construction and material suppliers to participate in transformative regional infrastructure investments. Superior Bowen would welcome the opportunity to support this project through asphalt production, paving, grading, and site construction services utilizing our experienced local workforce and longstanding commitment to safety and quality.

We believe the Heartland Data Center project represents a forward-looking investment that can strengthen regional infrastructure, support high-quality construction and technical jobs, and generate lasting economic benefits for local communities and businesses.

Thank you for your consideration and leadership regarding this important project.

Sincerely,

Brian Johanning

Executive Vice President

Data Center Project

From Carrie Copley <carriecopley@yahoo.com>
Date Mon 5/11/2026 8:40 PM
To City Clerk Distribution List <cityclerk@edgertonks.org>



Caution: External (carriecopley@yahoo.com)
First-Time Sender [Details](#)



[Safe](#) [Spam](#) [Phish](#) [More...](#)

[External Sender]

Dear Edgerton Planning Commission:

I am writing in support of the Data Center project looking at Edgerton. Not only will it provide high paying jobs, but we also don't need anymore projects that are going to continue to increase truck traffic. Anything that helps that is a benefit in my book.

I hope you consider approving this project instead of another warehouse with a bunch of trucks coming in and out every day, congesting our roads and causing accidents.

Thank you for your consideration.

Sincerely,
Carrie Copley
Horizon Trails
Gardner, KS

DAMAC Data Center

From Carrie Schmidt <cschmidt12@yahoo.com>

Date Sun 5/10/2026 10:35 PM

To Donald Roberts <mayor@edgertonks.org>; Clay Longanecker <clonganecker@edgertonks.org>; Josh Lewis <jlewis@edgertonks.org>; Ron Conus <rconus@edgertonks.org>; Bill Malloy <Bmalloy@edgertonks.org>; Deb Lebakken <dlebakken@edgertonks.org>; dlebakken@edgertonks.com <dlebakken@edgertonks.com>; Community Development <CommunityDevelopment@edgertonks.org>; info@edgertonks.org <info@edgertonks.org>; City Clerk Distribution List <cityclerk@edgertonks.org>

 5 attachments (10 MB)

MN_FS_Data_Centers_02.26.25a (1).pdf; Hilsdale Lake Water Usage (1).pdf; Kansas Surplus Water 2026 (1).pdf; Municipal Water Use Kansas_By Drainage Basin (1).pdf; Michigan Fors School_What Happens When Data Centers come to town (1).pdf;



External (cschmidt12@yahoo.com)



[Safe](#) [Spam](#) [Phish](#) [More...](#)

[External Sender]

I am attaching information and studies on data centers that are facts. I am also requesting that a moratorium is added to the agenda at the next city council meeting to halt the data center until you are able to do more reading of research to have a more educated vote. This decision cannot be taken lightly. If I find more information tomorrow I will send it your way as well.

Thank you,
Carrie Schmidt

Please cut and paste these links into your browser if needed.

<https://vtechworks.lib.vt.edu/server/api/core/bitstreams/484c56d7-9557-4c71-ad47-84ab67a21bad/content>

<https://stpp.fordschool.umich.edu/sites/stpp/files/2025-07/stpp-data-centers-2025.pdf>

<https://arxiv.org/pdf/2603.02705>

[Frontiers | Health implications of the rapid rise of data centers in Virginia: an exploratory assessment](#)

Frontiers | Health implications of the rapid rise of data centers in Virginia: an exploratory assessment

Driven by advances in cloud computing, cryptocurrency, and artificial intelligence, the rapid proliferation of data centers may pose severe human and planeta...



[\(PDF\) The data heat island effect: quantifying the impact of AI data centers in a warming world](#)

(PDF) The data heat island effect: quantifying the impact of AI data centers in a warming world

PDF | The strong and continuous increase of AI-based services leads to the steady proliferation of AI data centres worldwide with the unavoidable... | Find, read and cite all the research you need on ResearchGate



H I L L S D A L E L A K E - R E S E R V O I R A C C O U N T I N G

Calendar Year 2026

Date	Conservation Pool 2009 Survey Results		INFLOW Monthly Inflow (AF)	OUTFLOW Monthly Outflow (AF)	PRECIP Monthly Precip. (inches)	EVAP Reservoir Evap. (AF)	Future Use					Water Marketing					Water Quality				
	EOM Elevation (MSL)	EOM Storage (AF)					Inflow Share (AF)	Use (AF)	Evap. Share (AF)	EOM Storage (%)	EOM Storage (AF)	Inflow Share (AF)	Use (AF)	Evap. Share (AF)	EOM Storage (%)	EOM Storage (AF)	Inflow Share (AF)	Use (AF)	Evap. Share (AF)	EOM Storage (%)	EOM Storage (AF)
	915.58	70,815									39,871					16,236					
Jan	915.56	70,727	518	175	0.72	434	200	0	245	97%	40,055	93	428	100	83%	15,907	83	32	90	86%	14,764
Feb																					
Mar																					
Apr																					
May																					
Jun																					
Jul																					
Aug																					
Sep																					
Oct																					
Nov																					
Dec																					
TOTAL			518	175	0.72	434	200	0	245			93	428	100			83	32	90		

AF - Acre Feet
 EOM - End of Month
 Evap. - Evaporation
 Precip. - Precipitation
 MSL - Mean Sea Level

Future Use - Storage the State has contracted to purchase but has not yet been needed for the Water Marketing or Water Assurance programs.
 Water Marketing - Storage dedicated to serving customers of the Water Marketing Program, sufficient for a drought having a 2% chance occurrence.
 Water Conservation Plan triggers issued by KWO are based on remaining Water Marketing Storage, as follows:
 Water Watch: 75% Water Warning & Emergency: No specific remaining storage threshold. KWO will issue if any monitored drought indicator is observed to be more severe than the 2% chance condition.
 Water Quality - Storage that is managed jointly by the U.S. Army Corps of Engineers and the Kansas Water Office and is used to serve downstream water quality needs.

Municipal Water Use in Kansas, 2023

Published March 2025



Table of Contents

Abstract	Page 3
Introduction	Page 3
Definitions	Page 3
Population	Page 3
Regional Per Capita Water Use	Page 3
Unaccounted For Water	Page 3
Summary	Page 4
Tables	Pages 5-49
Table 1: Average GPCD for Public Water Suppliers by Region	Page 5
Table 2: Average GPCD by Regional Planning Area	Page 5
Table 3: Gallons Per Capita Day by Supplier	Page 6
Table 4: Unaccounted for water by Public Water Suppliers	Page 28
Figures	Page 50
Figure 1: Regions Used for GPCD Analysis	Page 50
Figure 2: Kansas Regional Planning Areas	Page 50
Useful Links	Page 51

Front cover images were provided by the Kansas Rural Water Association (KRWA) and the Kansas Water Office (KWO).

ABSTRACT

This report, prepared by the Kansas Water Office (KWO) in cooperation with the Kansas Department of Agriculture, Division of Water Resources (DWR), presents derivative statistics of 2023 municipal water use in Kansas. The per-capita usage and unaccounted for water percentage are presented for 802 public water suppliers. Regional averages of these statistics are also presented.

INTRODUCTION

Water use in Kansas is regulated by the Kansas Department of Agriculture, Division of Water Resources (DWR). The DWR requires annual water use reports from all public water suppliers with active water rights and from water suppliers that purchase water from State-owned storage in Federal reservoirs or from other water suppliers.

Information for the 802 suppliers in this publication was collected from annual water use reports filed by the public water suppliers. This includes cities and towns, rural water districts, and housing subdivisions. These public water suppliers provide information on quantity of water diverted, water purchased from and sold to other suppliers, sales to retail customers, metered free and unaccounted for water, population served, and number of connections.

The DWR reviews the water use data to ensure that the information is as accurate and complete as possible. The DWR derives the statistics on per capita usage and percent of water unaccounted for. The review is also important for identifying system adjustments or reporting errors.

POPULATION

The number of persons served directly by a public supplier is reported on the annual water

use report. When reported population is unavailable or unreliable an estimate is used. For cities, the estimated value is the census population plus the product of the number of connections outside of city limits and the county-average persons-per-household. For entities other than cities the product of the number of active residential connections and county-average persons-per household is used.

REGIONAL PER CAPITA WATER USE

Water usage in gallons per capita per day (GPCD) is calculated for each water system from reported data on water use and population served. GPCD usage for individual suppliers is based on amounts of water sold for residential and commercial uses, free uses, and unaccounted for water. GPCD figures do not include sales to other suppliers, industries, bulk uses, or farmsteads using more than 200,000 gallons per year.

Average GPCD figures are calculated for water suppliers in eight regions of the State which correspond to general patterns of per-capita water use and precipitation (Table 1, Figure 1). Averages were also calculated by source water Regional Planning Area (Table 2, Figure 2). This allows individual suppliers to be compared to the average use for similar geographical area (Table 3). GPCD use increases from Eastern to Western Kansas, primarily due to increased outdoor use in the more arid regions. Average GPCD usage by Kansas public water suppliers by region and size is shown in Table 1 for years 2019 – 2023. In 2023, average per-capita water usage ranged from 216 gallons per day in Region 1 in western most Kansas to 91 gallons per day in Region 7 among small public water suppliers in eastern Kansas.

UNACCOUNTED FOR WATER

The quantity of unaccounted for water is calculated by subtracting metered water

reported sold or provided free from the total raw water diverted and water purchased from other public suppliers. The fraction of total water diverted and purchased that is unaccounted for is presented by public supplier for 2019 through 2023 (Table 4).

SUMMARY

In 2023, 138 billion gallons of water were diverted for municipal use in Kansas. The state average per-capita usage was 113 gallons per

day. The average unaccounted-for water amongst public suppliers was 16 percent. Completion of the annual water use report by personnel at each water supply system is greatly appreciated. The data collected are valuable to the DWR for administering water rights, to the Kansas Water Office for preparing water conservation plans, to the Kansas Rural Water Association in identifying candidates for technical assistance with excessive unaccounted for water, and many others.

Table 1: Average GPCD for public water suppliers by region and size, 2019-2023

Region ¹	Year					Average
	2019	2020	2021	2022	2023	
1	205	264	230	265	216	236
2	180	212	209	238	201	208
3	168	201	201	225	187	197
4	139	140	160	169	150	152
5	105	109	107	120	118	112
6ML ²	118	123	125	135	131	126
6S	114	119	125	135	131	125
7L	105	114	122	125	128	119
7M	88	92	93	97	98	94
7S	76	81	85	90	91	85
8L	105	111	110	119	114	112
8M	83	89	91	96	97	91
8S	79	90	89	95	93	89
Statewide³	99	107	109	117	113	109

¹Large suppliers (L) serve 10,000 persons or more. Medium (M) suppliers serve 500 to 9,999 persons. Small (S) suppliers serve fewer than 500 persons.

²Medium and large are combined because of limited number of systems in region.

³State-wide GPCD is computed as the average of public-water supplier's GPCDs specified for use in a regional average.

Table 2: Average GPCD for public water suppliers by Regional Planning Area, 2019-2023

Source-water Regional Planning Area	Year					Average
	2019	2020	2021	2022	2023	
Cimarron(Ci)	191	224	218	273	213	223
Equus-Walnut (Ew)	88	93	94	102	102	96
Great Bend Prairie (Gb)	102	110	112	123	120	114
Kansas (Ks)	82	86	90	93	94	89
Marais Des Cygnes (Mc)	76	82	82	86	85	82
Missouri (Mo)	101	104	96	101	103	101
Neosho (Ne)	84	90	94	100	99	93
Red Hills (Rh)	138	146	156	160	147	149
Solomon-Republican (Sr)	115	127	129	131	134	127
Smoky Hill-Saline (Ss)	98	96	101	115	112	104
Upper Arkansas (Ua)	171	198	184	201	171	185
Upper Republican (Ur)	200	241	242	260	220	233
Upper Smoky Hill (Us)	172	219	213	247	201	210
Verdigris (Ve)	78	84	85	91	94	86
Statewide¹	99	107	109	117	113	109

¹State-wide GPCD is computed as the average of public-water suppliers' GPCDs specified for use in a regional average

Table 3: Gallons per capita day by public water supplier

Public Water Supplier	DWR ID	GPCD Region ¹	Source Water RPA	Gallons per capita-day					Average
				2019	2020	2021	2022	2023	
Abbyville	33073	6S	Ew	74	99	99	118	95	97
Abilene	16	7M	Ss	161	168	176	178	168	170
Agenda	87	7S	Ks	78	96	78	93	92	87
Agra	2841	5	Sr	71	70	69	78	66	71
Albert	2842	6S	Gb	73	82	87	102	80	85
Alexander	2843	5	Gb	74	106	100	110	84	95
Allen	33090	7S	Ne	52	50	58	58	57	55
Allen Co. RWD #04	23837	8S	Ne	73	NA	82	124	123	100
Allen Co. RWD #06	23839	8S	Ne	216	178	205	315	328	224
Allen Co. RWD #08	23841	8M	Ne	79	151	93	86	93	100
Allen Co. RWD #10	34203	8S	Ne	NA	174	NA	NA	NA	174
Allen Co. RWD #12	34599	8S	Ne	18	31	32	NA	NA	27
Allen Co. RWD #13	33777	8S	Ne	53	54	NA	56	62	56
Allen Co. RWD #15	34314	8S	Ne	53	66	53	63	66	60
Allen Co. RWD #16	33776	8S	Mc	69	109	161	215	133	138
Alma	2844	7M	Ks	93	90	86	90	96	91
Almena	20310	4	Sr	108	142	111	103	122	117
Alta Vista	30210	7S	Ks	57	61	60	61	60	60
Altamont	227	8M	Ne	65	66	55	58	58	60
Alton	20290	6S	Sr	113	122	275	286	344	228
Altoona	233	7S	Ve	56	61	62	63	NA	61
Andale	38067	7M	Ew	69	73	71	66	68	69
Anderson Co. RWD #01	34007	8S	Mc	84	85	88	99	110	93
Anderson Co. RWD #01C	57826	8M	Mc	89	105	104	93	82	95
Anderson Co. RWD #04	15200	8M	Mc	73	74	83	79	80	78
Anderson Co. RWD #05	23842	8M	Mc	54	67	63	59	59	61
Anthony	370	6ML	Rh	104	113	120	143	137	124
Arcadia	2847	8S	Mc	140	148	70	74	74	101
Argonia	411	7M	Rh	72	84	75	93	75	80
Arkansas City	413	7L	Ew	118	133	163	173	156	149
Arlington	416	6S	Ew	71	83	102	92	92	88
Arma	417	8M	Mc	67	82	68	73	78	73
Arnold	32854	4	Ss	212	156	154	227	143	178
Ashland	471	4	Rh	163	178	197	198	149	177
Assaria	484	7M	Ss	16	51	50	49	58	45
Atchison	488	8L	Mo	125	117	88	134	100	113
Atchison Co. RWD #01	33716	8S	Mo	64	65	62	69	63	65
Atchison Co. RWD #05C	58472	8M	Ks	96	95	104	105	102	101

Table 3: Gallons per capita day by public water supplier

Public Water Supplier	Gallons per capita-day								
	DWR ID	GPCD Region ¹	Source Water	2019	2020	2021	2022	2023	Average
			RPA						
Atchison Co. RWD #06	33720	8M	Ks	61	64	58	63	63	62
Atlanta	501	7S	Ew	57	68	68	73	73	68
Attica	504	6ML	Rh	283	355	342	181	230	278
Atwood	22248	2	Ur	134	177	154	171	148	157
Augusta	513	7M	Ew	129	144	140	138	134	137
Aurora	20287	7S	Ks	92	74	80	144	161	110
Axtell	536	7S	Ks	72	74	78	81	81	77
Baldwin	649	8M	Mc	73	110	73	71	73	80
Barber Co. RWD #01	34361	6S	Rh	147	149	197	201	204	180
Barber Co. RWD #02	15195	6S	Rh	456	454	521	606	596	527
Barber Co. RWD #03	15199	6S	Rh	116	121	124	129	90	116
Barnard	756	6S	Sr	66	61	81	71	NA	70
Barnes	764	7S	Ks	73	76	77	79	98	81
Bartlett	54997	8S	Ne	131	126	134	154	NA	136
Barton Co. RWD #02	15196	6ML	Gb	34	40	39	41	45	40
Barton Hills Water District	33006	6S	Gb	16	27	12	15	26	19
Baxter Springs	933	8M	Ne	219	208	209	219	437	258
Bazine	943	4	Gb	73	78	71	75	75	75
Beattie	22016	7S	Ks	82	76	66	71	69	73
Bel Aire	25219	7M	Ew	98	108	NA	117	126	112
Belle Plaine	1098	7M	Ew	84	88	94	87	81	87
Belleville	1099	7M	Sr	136	146	153	144	185	153
Beloit	1100	6ML	Sr	100	105	117	118	128	114
Belpre	1101	5	Gb	98	92	76	91	77	87
Belvidere	6162	5	Rh	NA	NA	NA	NA	NA	NA
Belvue	1104	7S	Ks	62	80	44	53	40	56
Bennington	1131	7M	Sr	85	95	82	71	84	84
Bentley	39238	7M	Ew	84	NA	NA	55	52	64
Benton	1147	7M	Ew	127	63	59	73	67	78
Bern	1196	7S	Mo	49	60	59	80	75	65
Beverly	1250	6S	Ss	113	107	74	127	118	108
Bird City	1319	1	Ur	244	296	248	401	321	302
Bison	1350	5	Gb	82	87	77	85	70	80
Blue Rapids	1461	7M	Ks	107	102	135	136	132	122
Bluff City	1465	6S	Rh	83	81	209	NA	87	115
Bogue	1520	4	Sr	104	107	139	110	114	115
Bonner Springs	1572	8M	Mo	100	98	112	112	108	106
Bourbon Co. RWD #02C	34048	8M	Ne	70	76	77	69	66	71
Bourbon Co. RWD #04	20867	8M	Mc	103	123	116	123	106	114

Table 3: Gallons per capita day by public water supplier

Public Water Supplier	DWR ID	GPCD Region ¹	Source Water RPA	Gallons per capita-day					Average
				2019	2020	2021	2022	2023	
Brewster	1909	2	Ur	182	217	243	290	224	231
Bronson	1997	8S	Mc	51	58	57	56	61	57
Brown Co. RWD #01	15192	8M	Mo	90	84	93	80	95	88
Brown Co. RWD #02	38841	8M	Ks	51	47	63	66	61	58
Brownell	20981	4	Gb	79	59	66	99	102	81
Bucklin	2193	4	Ua	126	144	160	187	199	163
Buffalo	2219	7S	Ve	59	67	67	63	65	64
Buffalo Hills Park	41252	5	Ss	52	45	39	40	43	44
Buhler	2224	6ML	Ew	124	138	140	157	147	141
Bunker Hill	2246	6S	Ss	88	73	79	88	71	80
Burden	2260	7M	Ew	77	78	82	81	78	79
Burdett	2264	5	Gb	86	102	98	134	149	114
Burlingame	2305	7M	Mc	66	66	NA	NA	54	62
Burlington	2306	7M	Ne	80	86	87	89	78	84
Burns	2312	7S	Ew	56	72	70	66	73	67
Burr Oak	2317	6S	Sr	125	136	118	101	81	112
Burrton	2331	7M	Ew	72	97	80	79	78	81
Bushton	2350	6S	Gb	101	80	106	108	118	103
Butler Co. RWD #01	15191	7M	Ew	54	61	NA	71	NA	62
Butler Co. RWD #02	29224	7M	Ew	69	66	NA	71	NA	69
Butler Co. RWD #03	29226	7M	Ne	69	72	68	78	102	78
Butler Co. RWD #04	29233	7M	Ew	81	87	85	79	87	84
Butler Co. RWD #05	29227	7M	Ew	66	75	84	85	81	78
Butler Co. RWD #06	29228	7M	Ew	76	95	103	111	108	98
Butler Co. RWD #07	54998	7M	Ew	41	44	43	46	49	45
Caldwell	32342	7M	Rh	92	93	111	108	105	102
Cambridge	2465	7S	Ew	90	73	NA	81	55	74
Caney	2504	7M	Ve	103	144	129	110	94	116
Canton	2512	7M	Ew	93	94	93	106	126	102
Carbondale	2521	7M	Ks	77	77	85	98	72	82
Cassoday	2644	7S	Ew	88	79	76	78	75	79
Cawker City	2673	6S	Sr	135	151	149	144	130	142
Cedar Point	34053	7S	Ne	101	73	114	NA	45	83
Cedar Vale	2689	7M	Ve	62	64	107	82	74	78
Centralia	39511	7M	Ks	70	72	72	68	71	71
Chanute	2740	8M	Ne	86	84	82	83	96	86
Chapman	20907	7M	Ss	136	129	120	129	132	129
Chase	20834	6S	Gb	82	81	94	90	87	87
Chase Co. RWD #01	34363	7S	Ne	83	94	86	83	80	85
Chautauqua	54999	7S	Ve	64	62	72	NA	NA	66

Table 3: Gallons per capita day by public water supplier

Public Water Supplier	DWR ID	GPCD Region ¹	Source Water RPA	Gallons per capita-day					Average
				2019	2020	2021	2022	2023	
Chautauqua Co. RWD #01	34459	7S	Ve	NA	NA	74	63	54	64
Chautauqua Co. RWD #02	35446	7S	Ve	92	100	100	105	115	102
Chautauqua Co. RWD #03	40615	7S	Ve	67	60	61	71	85	69
Chautauqua Co. RWD #04	61986	7S	Ve	96	128	NA	129	131	121
Cheney	2758	7M	Ew	132	147	124	159	157	144
Cherokee	2767	8M	Ne	63	55	48	48	44	52
Cherokee Co. RWD #01	15193	8M	Ne	85	110	93	109	120	103
Cherokee Co. RWD #02	15197	8M	Ne	82	83	81	88	83	83
Cherokee Co. RWD #03	15198	8M	Ne	120	138	140	151	131	136
Cherokee Co. RWD #04	15201	8M	Ne	91	111	112	122	115	110
Cherokee Co. RWD #05	32690	8S	Ne	56	70	64	70	68	66
Cherokee Co. RWD #07	34434	8S	Ne	101	89	117	83	NA	97
Cherokee Co. RWD #08	32219	8M	Ne	68	73	75	NA	74	73
Cherokee Co. RWD #09	55013	8M	Ne	44	43	42	62	43	47
Chetopa	2773	8M	Ne	89	105	86	80	93	91
Chicopee Rural Water District	34257	8S	Ne	57	65	72	71	68	67
Chisolm Creek Utility Authority	56957	7S	Ew	NA	NA	NA	NA	NA	NA
Cimarron	2830	3	Ua	194	225	236	277	211	229
Circleville	34337	7S	Ks	59	50	49	NA	NA	53
Clafin	2857	6ML	Gb	114	133	121	133	95	119
Clay Center	2934	7M	Ks	138	147	153	160	192	158
Clay Co. RWD #01	15203	7S	Ks	96	105	153	122	138	123
Clay Co. RWD #02	22113	7M	Ss	41	54	64	53	47	52
Clayton	2938	4	Sr	65	66	81	84	72	73
Clearview City	57736	8S	Ks	NA	NA	102	NA	NA	102
Clearwater	2939	7M	Ew	66	71	71	73	81	72
Clifton	2962	7M	Ks	88	92	102	103	97	96
Cloud Co. RWD #01	15204	7S	Sr	107	119	95	108	126	111
Clyde	2987	7M	Ks	119	116	137	124	127	125
Coal Hollow Water District	38417	8S	Ve	32	NA	NA	66	62	53
Coats	2992	6S	Gb	85	75	78	131	145	103
Coffey Co. RWD #02	22506	7M	Ne	NA	100	98	91	112	100
Coffey Co. RWD #03	33835	7M	Ne	86	78	85	85	76	82
Coffeyville	3018	7M	Ve	154	157	207	149	218	177

Table 3: Gallons per capita day by public water supplier

Public Water Supplier	DWR ID	GPCD Region ¹	Source Water RPA	Gallons per capita-day					Average
				2019	2020	2021	2022	2023	
Colby	3038	2	Ur	220	270	252	281	239	252
Coldwater	32341	5	Rh	134	139	135	174	164	149
Collyer	3096	4	Ss	48	56	96	118	95	83
Colony	3098	8S	Ne	61	59	51	139	90	80
Columbus	3103	8M	Ne	87	88	92	73	70	82
Colwich	37973	7M	Ew	73	80	88	77	80	79
Comanche Co. RWD #01	34392	5	Rh	105	95	88	89	142	104
Comanche Co. RWD #02	15211	5	Rh	NA	NA	NA	NA	NA	NA
Concordia	3122	7M	Sr	247	292	131	115	110	179
Conway Springs	3166	7M	Rh	64	106	NA	49	63	70
Coolidge	3203	1	Ua	305	378	187	228	157	251
Copeland	3247	3	Ua	171	201	209	258	205	209
Corning	34298	7S	Ks	79	94	92	87	NA	88
Cottonwood Falls	3323	7M	Ne	77	78	73	82	95	81
Council Grove	3340	7M	Ne	123	NA	107	110	154	123
Courtland	3351	7S	Sr	110	122	123	97	103	111
Cowley Co. RWD #01	15205	7M	Ew	90	88	91	96	97	92
Cowley Co. RWD #03	15218	7M	Ew	83	96	79	94	90	88
Cowley Co. RWD #04	34395	7M	Ew	89	109	101	146	133	116
Cowley Co. RWD #05	33722	7M	Ew	56	65	67	90	160	88
Cowley Co. RWD #06	15226	7M	Ew	59	79	73	77	85	75
Cowley Co. RWD #07	21282	7M	Ew	41	38	42	43	37	40
Cowley Co. RWD #08	41516	7S	Ew	130	NA	NA	92	76	99
Crawford Co. RWD #01	15206	8M	Mc	60	35	55	61	59	54
Crawford Co. RWD #01C	30949	8M	Mc	NA	139	155	176	149	155
Crawford Co. RWD #02	15212	8M	Ne	53	56	57	NA	55	55
Crawford Co. RWD #03	15219	8S	Mc	55	65	63	58	65	61
Crawford Co. RWD #04	15221	8M	Ne	59	70	63	74	71	67
Crawford Co. RWD #05	15224	8M	Ne	70	90	94	82	94	86
Crawford Co. RWD #06	15227	8M	Ne	75	86	97	102	94	91
Cuba	3543	7S	Ks	90	83	99	84	86	88
Cullison	3553	6S	Gb	113	142	127	128	145	131
Culver	23878	7S	Ss	62	59	64	61	NA	62
Cunningham	3571	6S	Rh	177	176	184	191	177	181
Damar	3670	5	Sr	95	107	103	135	NA	110
Dearing	33938	7S	Ve	53	67	82	78	64	69
Deerfield	3893	2	Ua	155	141	153	179	133	152
Delia	33123	7S	Ks	45	45	55	50	45	48
Delphos	3932	7S	Sr	68	68	67	79	87	74
Denison	34338	8S	Ks	35	37	50	41	44	41

Table 3: Gallons per capita day by public water supplier

Public Water Supplier	DWR ID	GPCD Region ¹	Source Water RPA	Gallons per capita-day					Average
				2019	2020	2021	2022	2023	
Derby (El Paso Water Company)	33488	7L	Ew	79	93	86	95	92	89
DeSoto	3977	8M	Ks	106	103	112	151	147	124
Dexter	4021	7S	Ew	65	63	70	81	83	73
Dickinson Co. RWD #01	15207	7M	Ss	110	109	110	194	204	145
Dickinson Co. RWD #02	15213	7M	Ss	99	97	103	122	125	109
Dighton	4108	3	Us	142	136	164	206	180	166
Dodge City	4207	4	Ua	122	144	145	161	148	144
Doniphan Co. RWD #03	15202	8M	Mo	48	44	42	43	41	44
Doniphan Co. RWD #05	23843	8M	Mo	87	102	NA	NA	114	101
Doniphan RWD 06	61940	8S	Mo	44	52	NA	NA	NA	48
Dorrance	21622	6S	Ss	45	56	54	46	52	51
Douglas Co. RWD #01	15209	8M	Ks	92	108	114	105	NA	105
Douglas Co. RWD #02	15215	8M	Ks	53	58	162	48	55	75
Douglas Co. RWD #03 (Tri-District Water System)	15220	8M	Ks	130	134	142	139	143	138
Douglas Co. RWD #04	55000	8M	Mc	73	75	75	78	90	79
Douglas Co. RWD #05	39221	8M	Mc	NA	65	59	62	68	63
Douglass	4304	7M	Ew	58	63	48	174	67	82
Downs	4336	6ML	Sr	121	114	126	133	120	123
Durham	4480	7S	Ne	79	75	93	80	80	81
Dwight	4511	7S	Ne	57	58	62	57	66	60
Easton	31979	8S	Mo	73	82	70	76	76	75
Edgerton	4610	8M	Ks	58	48	47	50	52	51
Edna	4619	8S	Ve	55	59	59	66	70	62
Effingham	4636	8M	Ks	61	70	65	66	67	66
El Dorado	4698	7L	Ew	137	149	157	166	162	154
Elbing	55002	7S	Ew	52	56	54	52	48	52
Elgin	4708	7S	Ve	107	82	118	213	135	131
Elk City	4709	7S	Ve	78	100	70	93	92	87
Elk Co. RWD #01	34256	7S	Ve	119	134	138	149	131	134
Elk Co. RWD #02	63748	7S	Ve	94	95	88	66	64	81
Elkhart	4710	1	Ci	204	285	305	311	238	269
Ellinwood	4717	6ML	Gb	98	102	112	119	103	107
Ellis	4753	5	Ss	89	102	106	87	90	95
Ellis Co. RWD #01C	57485	5	Ss	NA	NA	NA	268	253	260
Ellis Co. RWD #03	20643	5	Ss	38	46	47	49	40	44
Ellis Co. RWD #06	15222	5	Ss	127	124	126	139	153	134
Ellsworth	4780	6ML	Ss	121	142	127	112	120	125

Table 3: Gallons per capita day by public water supplier

Public Water Supplier	Gallons per capita-day								
	DWR ID	GPCD Region ¹	Source Water	2019	2020	2021	2022	2023	Average
			RPA						
Ellsworth RWD #01	30564	6ML	Ss	111	129	131	143	141	131
Elmdale	34037	7S	Ne	118	83	136	119	136	118
Emmett	4812	7S	Ks	58	49	49	48	49	51
Emporia	4817	7L	Ne	150	171	159	173	214	173
Englewood	4853	4	Rh	124	146	210	146	134	152
Ensign	4871	3	Ua	119	142	130	151	135	135
Enterprise	4882	7M	Ss	90	91	112	140	116	110
Erie	4908	8M	Ne	NA	79	NA	86	77	81
Esbon	4927	6S	Sr	110	81	145	124	101	112
Eskridge	26278	7M	Mc	108	122	118	152	137	127
Eudora	4974	8M	Ks	63	69	66	65	75	68
Eureka	4981	7M	Ve	105	112	114	119	106	111
Everest	5007	8S	Ks	81	80	83	83	75	81
Fall River	33228	7S	Ve	66	46	48	57	51	54
Finney Co. RWD #01	25245	2	Ua	96	131	119	120	117	117
Florence	5381	7S	Ne	80	81	106	114	108	98
Fontana	5403	8S	Mc	62	66	46	52	51	55
Ford	32601	4	Ua	NA	NA	108	69	98	92
Formoso	5429	6S	Sr	59	60	68	71	71	66
Fort Scott	5443	8M	Mc	144	151	156	188	151	158
Fowler	5489	3	Ci	121	138	123	NA	144	131
Frankfort	5566	7M	Ks	112	110	120	112	118	114
Franklin Co. RWD #01	21088	8M	Mc	36	56	39	44	44	44
Franklin Co. RWD #02	33669	8M	Mc	53	63	63	60	80	64
Franklin Co. RWD #03	34185	8S	Mc	52	65	NA	63	NA	60
Franklin Co. RWD #04	15223	8M	Mc	72	90	83	81	88	83
Franklin Co. RWD #05	5568	8M	Mc	53	56	57	54	55	55
Franklin Co. RWD #06	5569	8M	Mc	109	107	96	94	103	102
Fredonia	5611	7M	Ve	102	110	140	129	125	121
Frontenac	5729	8M	Ne	79	84	90	97	93	89
Fulton	5776	8S	Mc	65	74	81	76	95	78
Galatia	57758	6S	Ss	NA	NA	NA	NA	NA	NA
Galena	5822	8M	Ne	173	172	245	272	173	207
Galesburg	5823	8S	Ne	71	73	92	60	60	71
Galva	5832	7S	Ew	221	231	210	246	227	227
Garden City	5855	2	Ua	156	162	180	154	132	157
Garden Plain	30142	7M	Ew	94	114	110	162	104	117
Gardner	5862	8L	Ks	98	96	98	98	92	97
Garnett	5890	8M	Mc	81	126	NA	120	175	126
Gas	34316	8M	Ne	58	64	64	59	70	63

Table 3: Gallons per capita day by public water supplier

Public Water Supplier	Gallons per capita-day								
	DWR ID	GPCD Region ¹	Source Water	2019	2020	2021	2022	2023	Average
			RPA						
Gaylord	5932	6S	Sr	126	70	77	100	108	96
Geary Co. RWD #01	34329	7S	Ks	45	59	46	46	45	48
Geary Co. RWD #02	37064	7S	Ks	72	76	77	NA	NA	75
Geary Co. RWD #04	22303	7M	Ks	65	65	65	58	89	68
Geneseo	5973	6S	Ew	78	83	83	69	129	88
Geuda Springs	6018	7S	Ew	95	110	110	114	128	111
Girard	6127	8M	Ne	157	125	124	130	140	135
Glade	6137	5	Sr	128	151	105	85	66	107
Glasco	6139	7S	Sr	69	89	90	NA	86	83
Glen Elder	6157	6S	Sr	106	104	115	135	165	125
Goddard	6168	7M	Ew	56	65	68	74	76	68
Goessel	6219	7M	Ew	85	101	70	85	92	87
Goff	6233	7S	Ks	39	NA	42	NA	43	41
Goodland	6270	1	Ur	198	245	245	258	181	225
Gorham	6302	6S	Ss	68	68	88	75	62	72
Gove	6332	3	Us	96	121	170	293	150	166
Grainfield	6383	3	Ss	132	228	182	206	167	183
Grandview Plaza	6390	7M	Ks	90	94	89	78	103	91
Great Bend	23133	6ML	Gb	97	105	100	108	112	104
Greeley	6456	8S	Mc	51	50	48	50	49	50
Green	6463	7S	Ks	79	85	94	91	82	86
Greenleaf	6493	7S	Ks	107	91	87	94	94	95
Greensburg	6496	5	Gb	240	236	270	281	248	255
Greenwood Co. RWD #01	33858	7M	Ve	154	NA	NA	NA	NA	154
Greenwood Co. RWD #02	33859	7M	Ve	94	99	88	89	94	93
Greenwood Co. RWD #03	53335	7S	Ve	NA	110	NA	87	91	96
Grenola	20856	7S	Ve	53	56	57	58	73	59
Gridley	6524	7S	Ne	70	80	78	68	69	73
Grinnell	6570	3	Ss	154	188	185	243	205	195
Gypsum	6666	7S	Ss	80	82	81	82	91	83
Haddam	6698	7S	Ks	79	88	113	149	127	111
Halstead	6801	7M	Ew	59	64	64	68	63	64
Hamilton	6807	7S	Ve	58	58	62	90	66	67
Hamilton Co. RWD #01	22258	1	Ua	52	50	69	66	57	59
Hanover	6904	7	Ks	NA	NA	NA	NA	NA	NA
Hanston	6934	4	Gb	140	172	157	196	148	162
Hardtner	6957	6S	Rh	158	104	82	120	89	110

Table 3: Gallons per capita day by public water supplier

Public Water Supplier	DWR ID	GPCD Region ¹	Source Water RPA	Gallons per capita-day					Average
				2019	2020	2021	2022	2023	
Harper	7022	6ML	Rh	139	121	155	145	109	134
Harper Co. RWD #01	34302	6S	Rh	203	163	206	289	NA	215
Harper Co. RWD #02	33885	6S	Rh	273	307	374	359	392	341
Harper Co. RWD #04	36758	6S	Rh	98	110	135	140	118	120
Harper Co. RWD #05	34303	6S	Rh	NA	229	NA	NA	NA	229
Harper RWD 03	7018	6S	Rh	118	142	84	84	57	97
Hartford	7088	7M	Ne	37	46	43	51	59	47
Harvey Co. RWD #01	34259	7M	Ne	50	52	55	49	54	52
Harveyville	7124	7S	Mc	65	70	56	55	76	64
Haven	7184	6ML	Ew	94	112	113	118	121	112
Havensville	7186	7S	Ks	70	73	NA	97	78	79
Haviland	7187	5	Gb	98	99	106	134	117	111
Hays	7227	5	Ss	75	76	78	81	81	78
Hays City Suburban Estates	7224	5	Ss	107	125	150	146	119	129
Haysville	7238	7L	Ew	80	92	87	93	85	88
Hazelton	7246	6S	Rh	209	94	110	110	88	122
Herington	7470	7M	Ss	95	107	113	115	113	109
Herndon	7491	2	Ur	157	206	184	213	163	185
Hesston	7561	7M	Ew	126	149	137	172	166	150
Hiawatha	7590	8M	Mo	104	100	104	96	99	101
Highland	7636	8M	Mo	105	89	105	96	104	100
Hill City	7652	4	Ur	154	181	280	326	273	243
Hillsboro	7699	7M	Ne	96	105	119	104	106	106
Hillsdale Area Water Cooperative	65397	8L	Mc	NA	NA	NA	NA	NA	NA
Hoag Water District	34270	8	Ne	NA	NA	NA	NA	NA	NA
Hoisington	7858	6ML	Gb	98	98	94	96	102	98
Holcomb	7861	2	Ua	142	168	155	162	120	149
Holton	21613	7M	Ks	91	92	94	93	93	93
Holyrood	7958	6S	Gb	87	91	93	98	91	92
Hope	8005	7S	Ss	75	58	58	80	72	69
Horace	8013	1	Us	124	185	151	161	153	155
Horton	8041	8M	Ks	84	78	66	87	162	95
Howard	8100	7M	Ve	73	94	82	104	91	89
Howison Heights Water District	32822	7S	Ss	NA	NA	NA	NA	NA	NA
Hoxie	8123	3	Ur	206	240	250	280	245	244
Hoyt	55003	7M	Ks	55	59	60	67	NA	60
Hugoton	8223	2	Ci	266	309	322	383	336	323

Table 3: Gallons per capita day by public water supplier

Public Water Supplier	DWR ID	GPCD Region ¹	Source Water RPA	Gallons per capita-day					Average
				2019	2020	2021	2022	2023	
Humboldt	8241	8M	Ne	96	101	101	98	98	99
Hunters Island: Riley County Public Work	64397	7S	Ks	90	70	71	72	80	77
Hutchinson	8330	6ML	Ew	128	137	136	143	148	139
Independence	8379	7M	Ve	172	160	167	163	163	165
Ingalls	8384	3	Ua	NA	NA	NA	177	NA	177
Inman	8388	7M	Ew	120	134	127	146	147	135
Iola	8395	8M	Ne	103	107	102	102	102	103
Isabel	8436	6S	Rh	102	122	105	87	92	102
Iuka	33046	6S	Gb	NA	202	188	334	213	234
Jackson Co. RWD #01	23895	7M	Ks	56	59	65	78	80	68
Jackson Co. RWD #03	21090	7M	Ks	92	82	86	77	37	75
Jamestown	8540	7S	Sr	72	70	57	72	70	68
Jefferson Co. RWD #01	8627	8M	Ks	56	59	60	63	63	60
Jefferson Co. RWD #02	8628	8S	Ks	266	281	259	278	286	274
Jefferson Co. RWD #03	8622	8M	Ks	81	87	95	111	87	92
Jefferson Co. RWD #07	20800	8M	Ks	111	112	102	122	125	114
Jefferson Co. RWD #09	21091	8S	Ks	106	120	66	71	80	88
Jefferson Co. RWD #10	20750	8S	Ks	73	62	86	85	87	79
Jefferson Co. RWD #11	20752	8S	Ks	59	64	76	101	102	80
Jefferson Co. RWD #12	20541	8M	Ks	82	83	94	89	87	87
Jefferson Co. RWD #13	21092	8M	Ks	113	122	104	97	105	108
Jefferson Co. RWD #15	21093	8S	Ks	49	51	58	68	57	57
Jennings	8647	3	Ur	164	202	305	186	95	190
Jetmore	8671	4	Gb	123	136	132	163	137	138
Jewell	8672	6S	Sr	59	73	67	64	57	64
Jewell Co. RWD #01	15281	6S	Sr	205	225	210	209	238	217
Johnson City	8719	1	Ua	288	353	316	364	289	322
Johnson Co. RWD #07	23910	8M	Ks	144	138	140	148	156	145
Junction City	8979	7L	Ks	132	118	171	177	157	151
Kanopolis	9033	6S	Ss	62	56	60	60	72	62
Kanorado	9034	1	Ur	198	336	228	258	347	273
Kansas City Board of Public Utilities	20297	8L	Ks	149	147	141	144	143	145
Kechi	35516	7M	Ew	68	82	NA	79	82	78
Kensington	9265	6S	Sr	137	122	125	127	147	132
Kingman	9404	6ML	Rh	121	127	120	132	124	125
Kingman Co. RWD #01	33775	6S	Rh	92	71	63	63	77	73
Kinsley	9417	5	Gb	104	93	97	93	111	100
Kiowa	9423	6ML	Rh	106	101	NA	131	215	138

Table 3: Gallons per capita day by public water supplier

Public Water Supplier	DWR ID	GPCD Region ¹	Source Water RPA	Gallons per capita-day					Average
				2019	2020	2021	2022	2023	
Kirwin	9468	5	Sr	262	100	98	105	113	136
Kismet	9474	2	Ci	90	128	142	225	159	149
Konza Valley Water District	41962	7S	Ks	58	63	67	70	78	67
La Crosse	10038	5	Gb	102	113	121	149	153	127
La Cygne	10036	8M	Mc	91	88	92	105	83	92
La Harpe	33754	8S	Ne	143	171	181	197	151	169
Labette Co. RWD #01C	62649	8S	Ne	106	142	111	122	NA	121
Labette Co. RWD #03	55006	8S	Ve	57	70	79	85	86	75
Labette Co. RWD #06	23845	8M	Ve	55	74	100	101	89	84
Labette Co. RWD #07	55007	8M	Ne	54	56	70	79	82	68
Labette Co. RWD #08	23846	8M	Ne	114	127	125	155	155	135
Labette RWD #04	34378	8	Ne	NA	NA	NA	NA	NA	NA
Labette RWD #05	34379	8M	Ne	NA	NA	64	80	75	73
Lake Wabaunsee Improvement District	57322	7S	Mc	32	36	35	35	35	35
Lakeside Village Improvement District	10062	8S	Ks	107	113	208	157	90	135
Lakin	10065	2	Ua	192	200	205	245	188	206
Lancaster	10103	8S	Ks	48	53	49	51	50	50
Lane	10129	8S	Mc	131	107	51	55	55	80
Lane Co. RWD #01	20681	3	Us	193	216	206	252	198	213
Lansing (Lan-Del Water District)	34182	8M	Mo	72	80	81	74	76	77
Larned	10164	5	Gb	158	156	166	181	168	166
Latham	10220	7S	Ew	55	61	67	90	95	74
Lawrence	10239	8L	Ks	87	93	93	94	95	92
Leavenworth	10277	8L	Mo	127	116	110	94	103	110
Leavenworth Co. RWD #01	34178	8M	Mo	NA	NA	NA	NA	83	83
Leavenworth Co. RWD #01C	15267	8M	Mo	75	80	72	83	NA	78
Leavenworth Co. RWD #02	34179	8M	Mo	79	45	NA	NA	NA	62
Leavenworth Co. RWD #05	34180	8M	Ks	60	49	43	50	55	52
Leavenworth Co. RWD #06	33868	8M	Ks	62	68	72	110	NA	78
Leavenworth Co. RWD #07	33869	8M	Ks	69	72	75	68	73	71

Table 3: Gallons per capita day by public water supplier

Public Water Supplier	DWR ID	GPCD Region ¹	Source Water RPA	Gallons per capita-day					Average
				2019	2020	2021	2022	2023	
Leavenworth Co. RWD #08	34181	8M	Ks	65	68	65	NA	NA	66
Leavenworth Co. RWD #09	15276	8M	Ks	72	73	65	66	68	69
Leavenworth Co. RWD #10	34371	8M	Mo	62	76	86	84	83	78
Lebanon	10279	6S	Sr	75	69	66	63	82	71
Lebo	10280	7M	Mc	57	63	66	65	68	64
Lecompton	10287	8M	Ks	79	96	109	65	69	83
Lehigh	10317	7S	Ne	74	82	88	96	108	89
Lenora	10379	4	Sr	133	187	160	165	183	165
Leon	10381	7M	Ew	84	71	68	77	81	76
Leonardville	10399	7S	Ks	80	86	77	74	81	80
Leoti	10402	2	Us	145	163	159	182	148	159
LeRoy	10405	7M	Ne	56	63	68	NA	NA	62
Lewis	10437	5	Gb	124	106	134	117	74	111
Liberal	10482	2	Ci	NA	NA	NA	NA	NA	NA
Liebenthal	20452	5	Ss	61	60	68	55	55	60
Lincoln Center	10543	6ML	Ss	89	90	95	105	105	97
Lindsborg	10570	7M	Ss	96	97	87	90	90	92
Linn	10585	7S	Ks	75	80	87	93	115	90
Linn Co. RWD #01	33757	8M	Mc	163	181	213	187	255	200
Linn Co. RWD #02	34376	8M	Mc	70	82	101	77	81	82
Linn Co. RWD #03	33758	8M	Mc	79	103	86	99	105	94
Linn Valley	65869	8M	Mc	31	39	39	28	21	32
Linwood	10595	8S	Ks	58	54	61	56	65	59
Little Bear Mound	38330	7S	Ve	27	45	NA	NA	68	46
Little River	10607	6ML	Ew	95	100	108	115	112	106
Logan	10655	5	Sr	134	183	171	189	210	177
Long Island	10681	5	Sr	100	174	159	118	132	137
Longford	10693	7S	Ss	81	80	80	90	83	83
Longton	10695	7S	Ve	79	77	61	62	63	68
Lorraine	10713	6S	Gb	59	65	103	80	61	74
Louisburg	10734	8M	Mc	82	86	77	81	87	83
Lucas	10790	6S	Ss	63	67	87	80	80	75
Luray	10838	6S	Ss	64	84	63	50	50	62
Lyndon	10859	7M	Mc	67	71	72	69	67	69
Lyon Co. RWD #01	15230	7M	Mc	117	60	110	98	102	98
Lyon Co. RWD #02	23887	7M	Ne	61	61	108	58	64	70
Lyon Co. RWD #03	34166	7S	Ve	47	69	68	73	105	72

Table 3: Gallons per capita day by public water supplier

Public Water Supplier	DWR ID	GPCD Region ¹	Source Water RPA	Gallons per capita-day					Average
				2019	2020	2021	2022	2023	
Lyon Co. RWD #05	34168	7M	Mc	130	119	118	93	147	122
Lyons	10864	6ML	Gb	127	128	130	147	119	130
Macksville	10889	6ML	Gb	92	102	108	105	106	103
Madison	10909	7M	Ve	99	101	73	115	108	99
Mahaska	10934	7S	Ks	NA	NA	118	124	123	121
Maize	22377	7M	Ew	71	75	74	71	63	71
Manchester	10986	7S	Ss	NA	NA	140	NA	NA	140
Manhattan	10997	7L	Ks	113	109	123	129	133	121
Mankato	10999	6ML	Sr	234	206	213	214	227	219
Manter	11022	1	Ci	219	241	175	227	166	206
Maple Hill	11026	7M	Ks	55	63	65	67	67	63
Marais des Cygnes Public Utility Authority	58769	8L	Mc	NA	NA	NA	NA	NA	NA
Marion	11052	7M	Ne	105	104	112	117	122	112
Marion Co. Improvement District #02	51710	7S	Ne	40	43	44	42	47	43
Marion Co. RWD #01	15231	7M	Ss	118	98	118	154	113	120
Marion Co. RWD #02	55008	7S	Ne	51	59	54	66	75	61
Marion Co. RWD #04	23219	7M	Ne	87	94	79	88	101	90
Marquette	11075	7M	Ss	111	82	120	138	176	126
Marshall Co. RWD #01	15232	7S	Ks	NA	NA	110	97	93	100
Marshall Co. RWD #03	15261	7M	Ks	97	99	87	90	98	94
Marysville	11144	7M	Ks	99	101	106	95	114	103
Matfield Green	33118	7S	Ne	31	30	40	39	42	36
Mayetta	33072	7S	Ks	61	61	61	64	72	64
Mayfield	34417	7S	Rh	107	106	99	120	104	107
McCracken	32339	5	Ss	64	58	68	100	68	71
McCune	11416	8S	Ne	54	65	62	52	47	56
McDonald	11436	2	Ur	169	238	255	308	256	245
McFarland	22114	7S	Ks	60	61	60	57	61	60
McLouth	11588	8M	Ks	57	58	61	110	105	78
McPherson	11618	7L	Ew	135	143	140	155	148	144
McPherson Co. RWD #01	15233	7S	Ss	67	84	84	105	84	85
McPherson Co. RWD #02	34332	7S	Ew	105	115	NA	99	124	111
McPherson Co. RWD #03	34333	7S	Ew	76	91	96	126	104	99
McPherson Co. RWD #04	34334	7M	Ew	67	65	77	90	87	77

Table 3: Gallons per capita day by public water supplier

Public Water Supplier	DWR ID	GPCD Region ¹	Source Water RPA	Gallons per capita-day					Average
				2019	2020	2021	2022	2023	
McPherson Co. RWD #06	57737	7M	Ss	60	61	57	73	75	65
Meade	11636	3	Ci	163	195	191	214	185	190
Medicine Lodge	11663	6ML	Rh	97	94	167	268	227	171
Melvern	11736	7S	Mc	69	72	77	72	77	73
Miami Co. RWD #01	34426	8M	Mc	NA	56	67	60	NA	61
Miami Co. RWD #02	15252	8L	Mc	82	103	122	130	119	111
Miami Co. RWD #03	34427	8M	Mc	85	84	83	97	98	89
Miami Co. RWD #04	36767	8M	Mc	NA	NA	72	73	64	69
Milford	11883	7M	Ks	43	NA	NA	NA	NA	43
Miller Enterprises Inc Of Garden City	50843	2	Ua	NA	NA	NA	NA	NA	NA
Miltonvale	12083	7S	Ss	66	72	81	93	94	81
Minneapolis	12094	7M	Sr	85	101	99	107	116	102
Minneola	12095	4	Rh	135	167	167	194	145	161
Mitchell Co. RWD #02	15253	6ML	Ss	232	242	182	251	185	218
Mitchell Co. RWD #03	33397	6	Sr	NA	NA	NA	NA	NA	NA
Moline	12169	7S	Ve	60	62	56	63	53	59
Montezuma	12199	3	Ua	204	266	255	290	240	251
Montgomery Co. RWD #01	23847	7S	Ve	77	78	82	104	92	86
Montgomery Co. RWD #01C	55339	7M	Ve	60	NA	69	60	46	59
Montgomery Co. RWD #02	23848	7S	Ve	NA	NA	NA	NA	209	209
Montgomery Co. RWD #02C	61793	7M	Ve	NA	NA	NA	79	NA	79
Montgomery Co. RWD #06	55009	7M	Ve	116	125	86	100	112	108
Montgomery Co. RWD #08	23852	7S	Ve	NA	75	58	65	61	65
Montgomery Co. RWD #09	23853	7S	Ve	90	98	87	113	134	104
Montgomery Co. RWD #12	34326	7M	Ve	37	38	38	43	40	39
Montgomery Co. RWD #14	56883	7S	Ve	127	122	NA	NA	NA	125
Moran	12278	8M	Ne	82	158	82	93	97	103
Morganville	12308	7S	Ks	113	110	110	145	112	118
Morland	12319	4	Ur	138	223	215	303	342	244
Morrill	12322	8S	Mo	62	54	47	43	45	50

Table 3: Gallons per capita day by public water supplier

Public Water Supplier	DWR ID	GPCD Region ¹	Source Water RPA	Gallons per capita-day					Average
				2019	2020	2021	2022	2023	
Morris Co. RWD #01	34865	7M	Ne	158	158	175	153	161	161
Morrowville	12363	7S	Ks	62	82	85	104	90	85
Moscow	12380	2	Ci	280	279	250	323	263	279
Mound City	12429	8M	Mc	83	97	97	99	102	96
Mound Valley	12430	8S	Ve	66	61	51	66	63	61
Moundridge	12431	7M	Ew	106	118	102	111	118	111
Mount Hope	12432	7M	Ew	162	163	135	131	116	142
Mulberry	12476	8M	Mc	67	70	69	74	68	69
Mullinville	20461	5	Gb	65	78	11	18	166	67
Mulvane	12492	7M	Ew	78	71	67	83	77	75
Munden	12497	7S	Ks	61	57	71	79	63	66
Muscotah	12560	8S	Ks	NA	78	83	83	112	89
Narka	12605	7S	Ks	103	99	83	94	105	97
Nashville	12607	6S	Rh	NA	NA	NA	NA	NA	NA
Natoma	12620	6S	Ss	73	72	82	149	93	94
Nemaha Co. RWD #01	15234	7S	Mo	200	185	172	100	129	157
Nemaha Co. RWD #03	15262	7M	Mo	271	158	89	85	81	137
Nemaha Co. RWD #04	34423	7M	Mo	125	101	91	109	87	102
Neodesha	12743	7M	Ve	79	79	87	82	79	81
Neosho Co. RWD #01C	55011	8M	Ne	NA	NA	NA	185	199	192
Neosho Co. RWD #02	15254	8M	Ne	71	83	88	84	81	82
Neosho Co. RWD #03	55010	8S	Ne	91	NA	NA	NA	94	93
Neosho Co. RWD #04	39323	8M	Ne	192	196	168	195	195	189
Neosho Co. RWD #08	34393	8S	Ne	NA	98	94	113	118	106
Ness City	12744	4	Gb	116	129	157	152	127	136
Netawaka	34339	7S	Ks	89	88	80	82	80	84
New Strawn	12765	7S	Ne	71	86	85	80	100	84
Newton	12788	7L	Ew	73	79	78	83	84	79
Nickerson	12853	6ML	Ew	66	73	86	83	77	77
Nicodemus Township	12857	4	Ur	418	219	455	320	102	317
Norcatour	12973	3	Ur	93	115	126	112	101	110
North Newton	26573	7M	Ew	74	82	79	87	89	82
Norton	13015	4	Sr	150	186	192	202	179	182
Norton Co. RWD #01	15235	4	Sr	31	28	27	40	30	31
Nortonville	13022	8M	Ks	72	70	66	74	72	71
Norwich	13023	6S	Rh	62	112	101	102	120	99
Oakley	13097	2	Ur	197	249	224	248	211	226
Oberlin	13110	3	Ur	131	155	166	167	161	156
Offerle	13167	5	Gb	86	95	84	105	96	93
Ogden	13169	7M	Ks	62	54	60	NA	77	63

Table 3: Gallons per capita day by public water supplier

Public Water Supplier	Gallons per capita-day								
	DWR ID	GPCD Region ¹	Source Water RPA	2019	2020	2021	2022	2023	Average
Oketo	13183	7S	Ks	55	71	75	101	118	84
Olathe	13184	8L	Ks	74	97	102	108	111	99
Olmitz	20925	6S	Gb	86	86	91	104	103	94
Olpe	13210	7M	Ne	57	62	65	62	57	61
Olsburg	34885	7S	Ks	111	73	76	73	77	82
Onaga	13244	7M	Ks	64	71	72	71	81	72
Oneida	13245	7S	Mo	50	54	56	55	48	53
Osage City	13263	7M	Mc	70	74	76	76	76	74
Osage Co. RWD #02	15255	7S	Mc	51	68	68	66	65	64
Osage Co. RWD #03	15263	7M	Mc	109	110	106	116	102	109
Osage Co. RWD #04	15268	7M	Mc	88	89	81	105	105	94
Osage Co. RWD #05	15119	7M	Mc	68	75	74	73	81	74
Osage Co. RWD #06	40021	7S	Mc	91	89	85	80	NA	86
Osage Co. RWD #07	33876	7M	Mc	59	64	72	92	88	75
Osage Co. RWD #08	55012	7M	Mc	NA	NA	NA	159	NA	159
Osawatomie	13264	8M	Mc	90	109	91	90	99	96
Osborne	13269	6ML	Sr	118	129	125	136	129	127
Osborne Co. RWD #01A	15249	6S	Sr	NA	NA	NA	NA	NA	NA
Osborne Co. RWD #02	25758	6S	Sr	138	148	150	192	171	160
Oskaloosa	13276	8M	Ks	75	81	77	140	75	89
Oswego	13299	8M	Ne	89	85	92	92	92	90
Otis	13300	5	Gb	74	77	78	105	124	92
Ottawa	13308	8L	Mc	89	102	99	105	116	102
Ottawa Co. RWD #01	15282	7S	Sr	94	98	126	148	136	121
Ottawa Co. RWD #02	15256	7M	Sr	110	105	117	99	103	107
Overbrook	13323	7M	Mc	65	58	75	65	61	65
Oxford	13353	7M	Ew	82	88	87	85	91	86
Ozawkie	13358	8M	Ks	61	75	65	92	75	73
Palco	13384	5	Sr	85	84	74	78	83	81
Palmer	13393	7S	Ks	127	141	159	146	148	144
Paola	13415	8M	Mc	82	80	86	90	92	86
Paradise	13419	6S	Ss	80	88	82	100	98	89
Park	13430	3	Ur	394	429	274	237	282	323
Park City	13427	7M	Ew	NA	123	126	134	128	128
Parsons	13488	8M	Ne	135	138	142	152	162	146
Pawnee Rock	31008	6S	Gb	76	74	76	66	71	72
Paxico	13551	7S	Ks	63	66	75	71	65	68
Paxton Addition	29202	1	Ur	NA	304	293	356	236	297
Peabody	13561	7M	Ne	65	75	108	NA	88	84
Perry	20928	8M	Ks	71	72	80	69	70	72

Table 3: Gallons per capita day by public water supplier

Public Water Supplier	DWR ID	GPCD Region ¹	Source Water RPA	Gallons per capita-day					Average
				2019	2020	2021	2022	2023	
Peru	13688	7S	Ve	38	43	41	NA	32	38
Phillips Co. RWD #01	15236	5	Sr	110	129	139	162	152	138
Phillipsburg	13808	5	Sr	161	118	110	115	125	126
Pittsburg	13876	8L	Ne	95	103	113	130	113	111
Plains	19243	3	Ci	182	207	246	276	239	230
Plainville	13883	5	Ss	79	69	106	126	112	99
Pleasanton	13889	8M	Mc	100	99	113	121	111	109
Pomona	13946	8M	Mc	71	75	89	77	75	77
Portis	13980	6S	Sr	80	80	101	66	80	82
Pottawatomie Co. RWD #01	15237	7M	Ks	101	110	119	70	131	106
Pottawatomie Co. RWD #02	21005	7M	Ks	77	87	93	95	102	91
Pottawatomie Co. RWD #03	34075	7M	Ks	85	86	103	78	65	83
Pottawatomie Co. RWD #04	50614	7M	Ks	110	114	116	126	134	120
Potwin	14009	7S	Ew	55	60	86	76	67	69
Powhattan	33375	8S	Ks	NA	NA	NA	85	91	88
Prairie View	14043	5	Sr	105	127	112	135	125	121
Pratt	14050	6ML	Gb	224	210	213	252	225	225
Prescott	22619	8S	Mc	40	39	38	52	54	45
Preston	14074	6S	Gb	57	141	76	95	59	86
Pretty Prairie	14078	6ML	Ew	108	105	104	113	103	107
Princeton	14125	8S	Mc	71	61	NA	59	NA	63
Protection	14152	5	Rh	167	164	170	169	160	166
Quenemo	14200	7S	Mc	NA	NA	NA	128	NA	128
Quinter	14220	3	Ur	121	148	158	185	168	156
Randall	14294	6S	Sr	54	93	64	125	59	79
Randolph	14309	7S	Ks	67	69	80	65	69	70
Ransom	14322	4	Ss	143	90	82	101	96	102
Rantoul	14323	8S	Mc	54	57	39	37	69	51
Raymond	14383	6S	Gb	108	102	154	144	169	135
Reading	14386	7S	Mc	44	43	NA	NA	60	49
Red Bud Lake Improvement District	14391	7S	Ss	40	35	34	31	32	35
Reno Co. RWD #01	15238	6S	Ew	72	85	72	86	78	79
Reno Co. RWD #03	15264	6ML	Ew	38	47	47	59	45	47
Reno Co. RWD #04	34153	6ML	Ew	31	29	30	30	28	30
Reno Co. RWD #08	29055	6S	Ew	227	216	247	255	242	237

Table 3: Gallons per capita day by public water supplier

Public Water Supplier	DWR ID	GPCD Region ¹	Source Water RPA	Gallons per capita-day					Average
				2019	2020	2021	2022	2023	
Reno Co. Water District #101	30458	6S	Ew	222	205	217	258	255	231
Republic	14580	7S	Sr	150	156	219	171	161	171
Republic Co. RWD #01	15239	7S	Sr	NA	453	556	477	525	503
Republic Co. RWD #02	15257	7M	Sr	153	169	182	173	209	177
Reserve	14589	8S	Mo	134	105	67	63	52	84
Rexford	14597	2	Ur	228	249	274	263	278	259
Rice Co. RWD #01	40441	6ML	Ew	103	108	105	93	128	107
Richmond	14683	8S	Mc	63	66	79	74	74	71
Riley	14753	7M	Ks	71	75	76	68	72	73
Riley Co. RWD #01	15240	7M	Ks	53	58	80	60	62	63
Robinson	14882	8S	Mo	59	75	54	53	47	57
Rocky Ford Water Company	35916	7S	Ks	NA	NA	NA	NA	NA	NA
Rolla	14999	1	Ci	196	224	201	226	190	207
Rooks Co. RWD #01	15283	5	Sr	90	74	75	73	98	82
Rooks Co. RWD #02	15258	5	Ss	59	67	67	70	72	67
Rooks Co. RWD #03	15265	5	Sr	161	130	197	204	201	179
Rose Hill	15031	7M	Ew	45	73	69	83	68	67
Roseland	34296	8S	Ne	56	55	64	77	52	61
Rossville	15076	7M	Ks	74	72	71	66	69	71
Rozel	15118	5	Gb	154	184	195	187	147	173
Rush Center	15286	5	Gb	123	128	144	128	107	126
Rush Co. RWD #01	15241	5	Ss	141	151	152	271	277	198
Russell	15300	6ML	Ss	110	111	118	131	173	129
Russell Co. RWD #01	15242	6S	Ss	90	91	102	132	110	105
Russell Co. RWD #02	15259	6S	Ss	NA	NA	199	198	256	218
Russell Co. RWD #03	20482	6ML	Gb	138	147	131	94	95	121
Russell Co. RWD #04	15269	6S	Ss	337	294	197	186	291	261
Sabetha	15348	7M	Ks	111	124	113	111	110	114
Salina	15366	7L	Ss	94	95	96	98	105	97
Saline Co. RWD #01	15243	7S	Ss	56	43	48	59	54	52
Saline Co. RWD #02	15260	7S	Ss	150	89	93	108	165	121
Saline Co. RWD #03	34359	7M	Ss	67	76	68	67	81	72
Saline Co. RWD #04	15270	7M	Ss	97	90	113	99	125	105
Saline Co. RWD #06	15273	7S	Ss	97	82	80	80	70	82
Saline Co. RWD #07	35556	7S	Ss	54	58	73	69	55	62
Saline Co. RWD #08	50063	7S	Ss	118	139	132	120	117	125
Satanta	15444	2	Ci	185	209	216	260	212	217
Sawyer	15461	6S	Gb	117	123	125	144	112	124

Table 3: Gallons per capita day by public water supplier

Public Water Supplier	DWR ID	GPCD Region ¹	Source Water RPA	Gallons per capita-day					Average
				2019	2020	2021	2022	2023	
Scammon	15474	8S	Ne	54	64	99	87	76	76
Scandia	15476	7S	Sr	110	123	128	144	128	127
Schoenchen	61775	5	Ss	59	70	63	79	56	65
Scott City	21022	2	Us	212	243	223	247	204	226
Scranton	16052	7M	Mc	NA	NA	102	96	43	80
Sedan	16086	7M	Ve	75	90	69	85	70	78
Sedgwick	16088	7M	Ew	63	64	66	70	73	67
Sedgwick Co. RWD #01	24790	7M	Ew	NA	62	60	74	66	66
Sedgwick Co. RWD #02	23894	7M	Ew	69	83	75	90	NA	79
Sedgwick Co. RWD #03	24791	7M	Ew	68	69	64	69	70	68
Sedgwick Co. RWD #04	26327	7M	Ew	NA	80	57	54	53	61
Selden	16120	3	Ur	220	275	243	269	237	249
Seneca	16149	7M	Mo	113	162	164	155	163	151
Severy	37790	7S	Ve	95	80	96	116	107	99
Sharon	16223	6S	Rh	181	170	178	174	150	171
Sharon Springs	16222	1	Us	174	238	205	238	227	216
Shawnee Co. RWD #01C	23881	7M	Ks	52	57	59	59	61	58
Shawnee Co. RWD #02C	31683	7M	Ks	69	NA	57	NA	61	62
Shawnee Co. RWD #03C	58394	7M	Ks	100	106	110	118	123	111
Shawnee Co. RWD #04C	58395	7L	Ks	75	116	119	89	126	105
Shawnee Co. RWD #08	15275	7L	Ks	54	57	57	56	57	56
Silver Lake	16478	7M	Ks	NA	64	61	68	63	64
Simmons Subdivision Sanitation System	60582	7S	Ew	47	51	46	42	46	46
Simpson	16521	6S	Sr	68	73	65	72	73	70
Smith Center	16631	6ML	Sr	160	166	152	167	167	162
Smith Co. RWD #01	24115	6S	Sr	251	289	296	301	290	285
Soldier	34340	7S	Ks	NA	35	40	55	51	45
Solomon	16867	7M	Sr	85	84	95	94	96	91
South Haven	16878	7S	Rh	122	138	84	NA	106	113
South Hutchinson	16879	6ML	Ew	154	158	172	159	156	160
Spearville	16915	4	Ua	119	137	135	164	132	137
Speed	16919	5	Sr	56	82	60	67	69	67
Spivey	16977	6S	Rh	69	NA	NA	NA	NA	69
Spring Hill	20489	8M	Mc	54	65	64	67	43	59
St. Francis	17027	1	Ur	226	251	243	298	236	251
St. George	17028	7M	Ks	113	115	103	180	127	128
St. John	17029	6ML	Gb	107	85	97	104	162	111
St. Marys	17032	7M	Ks	89	121	101	110	98	104
St. Paul	17033	8M	Ne	95	104	97	111	102	102

Table 3: Gallons per capita day by public water supplier

Public Water Supplier	DWR ID	GPCD Region ¹	Source Water RPA	Gallons per capita-day					Average
				2019	2020	2021	2022	2023	
Stafford	17056	6ML	Gb	103	99	110	138	114	113
Sterling	17250	6ML	Gb	83	77	85	84	216	109
Stockton	17320	5	Sr	129	121	145	157	137	138
Strong City	17454	7S	Ne	67	63	89	88	83	78
Sublette	17539	2	Ci	NA	251	221	281	215	242
Suburban Water Company	24951	8M	Ks	78	97	105	105	117	100
Summerfield	17582	7S	Mo	95	107	104	139	137	116
Sumner Co. RWD #01	34418	7S	Ew	136	95	94	90	98	103
Sumner Co. RWD #02	34419	7S	Ew	81	NA	88	131	131	108
Sumner Co. RWD #03	34420	7S	Rh	NA	119	106	124	144	123
Sumner Co. RWD #04	25252	7M	Ew	69	72	71	66	70	70
Sumner Co. RWD #05	24552	7M	Rh	43	42	45	48	56	47
Sumner Co. RWD #06	34318	7S	Ew	85	82	86	92	93	88
Sundowner Inc.	52848	7S	Ss	35	37	NA	NA	NA	36
Susank	55014	6S	Gb	69	67	69	56	80	68
Sylvan Grove	17695	6S	Ss	97	88	102	102	105	99
Sylvia	17700	6S	Gb	133	171	123	110	92	126
Syracuse	17702	1	Ua	307	371	363	388	334	352
Tescott	17827	7S	Ss	68	68	77	74	79	73
Thayer	17839	8S	Ve	177	155	171	174	196	175
Timber Creek Water and Sewer District	36072	7M	Ks	107	129	135	135	142	130
Timken	18023	5	Gb	85	80	104	79	87	87
Tipton	18041	6S	Sr	84	88	110	146	140	113
Tonganoxie	18085	8M	Ks	82	81	76	74	82	79
Topeka	18096	7L	Ks	115	123	129	122	132	124
Toronto	18107	7S	Ve	60	60	NA	76	124	80
Towanda	18112	7M	Ew	72	69	142	NA	194	119
Trego Co. RWD #01	28343	4	Ss	249	82	185	172	167	171
Trego Co. RWD #02	36275	4	Ss	163	146	184	174	172	168
Tribune	18175	1	Us	197	249	224	268	224	232
Troy	18204	8M	Mo	96	82	86	84	81	86
Turon	18272	6S	Gb	74	76	75	99	84	82
Tuttle Creek Water Co.	36200	7S	Ks	NA	NA	NA	NA	NA	NA
Two Lions Subdivision	16725	2	Ua	144	131	140	145	143	141
Udall	18307	7M	Ew	69	72	73	75	69	72
Ulysses	18327	2	Ua	196	225	226	232	203	216
Uniontown	18355	8S	Mc	66	71	64	64	55	64

Table 3: Gallons per capita day by public water supplier

Public Water Supplier	DWR ID	GPCD Region ¹	Source Water RPA	Gallons per capita-day					Average
				2019	2020	2021	2022	2023	
University Park Water District	18363	7S	Ks	37	46	49	44	50	45
Utica	18454	4	Gb	155	206	263	291	331	249
Valley Center	18473	7M	Ew	63	66	63	85	67	69
Valley Falls	18474	8M	Ks	85	83	204	177	196	149
Vermillion	22017	7S	Ks	101	97	91	103	85	96
Victoria	18587	5	Ss	49	56	51	60	55	54
Viola	18599	7S	Ew	66	78	88	109	81	84
Virgil	21302	7S	Ve	54	50	73	53	86	63
Wabaunsee Co. RWD #01	15244	7S	Ks	79	99	108	83	87	91
Wabaunsee Co. RWD #02	33095	7M	Ks	94	106	127	121	134	116
WaKeeney	18717	4	Ss	156	151	153	177	183	164
Wakefield	18718	7M	Ks	84	93	81	91	96	89
Waldo	18732	6S	Ss	70	75	83	71	83	76
Wallace	18794	1	Ss	140	161	132	163	121	143
Wallace Co. RWD #01	15245	1	Us	208	322	331	291	201	271
Walnut	33755	8S	Ne	97	124	103	103	90	103
Walton	55500	7S	Ew	58	61	67	58	68	62
Wamego	18859	7M	Ks	101	116	124	134	138	123
Washington	18929	7M	Ks	112	126	119	104	112	115
Washington Co. RWD #01	15246	7M	Ks	97	110	112	151	158	126
Washington Co. RWD #02	20337	7M	Ks	135	161	121	137	161	143
Water One - Johnson Co.	8693	8L	Mo	127	137	135	147	148	139
Waterville	18965	7M	Ks	91	87	92	92	101	93
Wathena	21969	8M	Mo	112	115	120	131	114	118
Waverly	18996	7M	Mc	64	61	65	64	62	63
Weir	19108	8M	Ne	65	64	67	72	66	67
Wellington	19136	7M	Rh	92	NA	126	151	114	121
Wellsville	19154	8M	Mc	73	63	72	NA	NA	69
West Hills Water Company	41680	6S	Ew	174	184	134	197	283	194
West Mineral	19242	8S	Ne	37	61	111	99	68	75
Westmoreland	19288	7M	Ks	63	63	64	64	73	65
Wetmore	19290	7S	Ks	67	80	90	78	73	78
White City	19348	7M	Ne	54	51	135	122	62	85
White Cloud	33077	8S	Mo	170	404	271	274	398	303
Whitewater	19409	7M	Ew	65	64	72	69	64	67

Table 3: Gallons per capita day by public water supplier

Public Water Supplier	DWR ID	GPCD Region ¹	Source Water RPA	Gallons per capita-day					Average
				2019	2020	2021	2022	2023	
Whiting	19416	7S	Ks	56	65	68	72	69	66
Wichita	19449	7L	Ew	98	98	110	118	108	106
Williamsburg	19628	8S	Mc	67	74	NA	66	69	69
Willis	34204	8S	Mo	NA	NA	64	159	137	120
Wilroads Garden Improvement	19647	4	Ua	NA	NA	NA	NA	NA	NA
Wilsey	56248	7S	Ne	59	34	48	54	52	49
Wilson	20377	6ML	Ss	115	101	88	87	77	94
Wilson Co. RWD #01	33731	7S	Ve	81	84	77	95	127	93
Wilson Co. RWD #02	33732	7S	Ve	55	65	79	56	54	62
Wilson Co. RWD #04	34323	7S	Ve	59	88	105	93	121	93
Wilson Co. RWD #05	23885	7S	Ve	34	25	35	31	26	30
Wilson Co. RWD #06	34324	7S	Ve	61	86	85	59	113	81
Wilson Co. RWD #07	33735	7S	Ve	84	103	82	188	90	109
Wilson Co. RWD #08	51703	7S	Ve	55	82	64	56	92	70
Wilson Co. RWD #12	34325	7S	Ve	53	56	NA	61	NA	57
Wilson Co. RWD #13	34529	7S	Ve	87	81	75	92	108	89
Wilson Lake Estates (Russell Co)	32937	6S	Ss	69	91	90	86	80	83
Winchester	19671	8M	Ks	57	60	55	61	NA	58
Windom	38134	7S	Ew	94	93	NA	142	69	100
Winfield	19679	7L	Ew	124	140	149	149	163	145
Winona	19724	2	Us	228	322	299	329	327	301
Woodbine	40930	7S	Ss	NA	56	NA	NA	NA	56
Woodson Co. RWD #01	15247	7M	Ne	61	66	66	76	75	69
Woodston	19886	5	Sr	94	199	61	66	64	97
Wright Improvement District	25906	4	Ua	NA	NA	NA	NA	NA	NA
Yates Center	19999	7M	Ne	98	100	106	118	99	104
Zenda	20148	6S	Rh	NA	NA	106	110	119	111

¹Large suppliers (L) serve 10,000 persons or more. Medium (M) suppliers serve 500 to 9,999 persons. Small (S) suppliers serve fewer than 500 persons; medium and large are combined for Region 6 because of the limited number of systems

Table 4: Unaccounted for water by public water supplier

Public Water Supplier	Person ID	GPCD Region ¹	Source Water RPA	Percent Unaccounted					Average
				2019	2020	2021	2022	2023	
Abbyville	33073	6S	Ew	14	18	11	14	12	14
Abilene	16	7M	Ss	16	13	12	12	8	12
Agenda	87	7S	Ks	13	13	7	2	2	7
Agra	2841	5	Sr	13	2	9	6	12	8
Albert	2842	6S	Gb	11	9	14	24	18	15
Alexander	2843	5	Gb	2	6	10	2	1	4
Allen	33090	7S	Ne	1	2	1	3	1	2
Allen Co. RWD #04	23837	8S	Ne	NA	NA	9	29	9	16
Allen Co. RWD #06	23839	8S	Ne	10	4	NA	2	4	5
Allen Co. RWD #08	23841	8M	Ne	NA	38	46	44	35	41
Allen Co. RWD #10	34203	8S	Ne	NA	NA	NA	NA	NA	NA
Allen Co. RWD #12	34599	8S	Ne	NA	NA	NA	NA	NA	NA
Allen Co. RWD #13	33777	8S	Ne	12	2	NA	6	18	9
Allen Co. RWD #15	34314	8S	Ne	NA	NA	8	16	8	11
Allen Co. RWD #16	33776	8S	Mc	20	17	16	NA	NA	18
Alma	2844	7M	Ks	17	5	8	9	8	9
Almena	20310	4	Sr	33	37	14	17	14	23
Alta Vista	30210	7S	Ks	NA	5	7	11	10	8
Altamont	227	8M	Ne	8	10	10	11	15	11
Alton	20290	6S	Sr	27	NA	37	63	56	46
Altoona	233	7S	Ve	27	29	24	31	NA	28
Andale	38067	7M	Ew	6	6	5	4	5	5
Anderson Co. RWD #01	34007	8S	Mc	16	15	12	12	21	15
Anderson Co. RWD #01C	57826	8M	Mc	23	31	28	15	NA	24
Anderson Co. RWD #04	15200	8M	Mc	32	28	38	30	34	33
Anderson Co. RWD #05	23842	8M	Mc	16	22	17	15	11	16
Anthony	370	6ML	Rh	19	19	21	28	22	22
Arcadia	2847	8S	Mc	53	59	27	25	30	39
Argonia	411	7M	Rh	5	11	7	13	7	8
Arkansas City	413	7L	Ew	11	12	16	19	6	13
Arlington	416	6S	Ew	4	4	22	5	NA	9
Arma	417	8M	Mc	14	14	11	14	17	14
Arnold	32854	4	Ss	NA	NA	NA	NA	NA	NA
Ashland	471	4	Rh	17	14	12	11	11	13
Assaria	484	7M	Ss	19	12	7	14	25	15
Atchison	488	8L	Mo	13	13	11	24	20	16
Atchison Co. RWD #01	33716	8S	Mo	6	9	7	9	7	8
Atchison Co. RWD #05C	58472	8M	Ks	27	23	23	21	18	22
Atchison Co. RWD #06	33720	8M	Ks	21	14	12	12	14	15
Atlanta	501	7S	Ew	18	14	10	2	1	9

Table 4: Unaccounted for water by public water supplier

Public Water Supplier	Person ID	GPCD Region ¹	Source Water RPA	Percent Unaccounted					
				2019	2020	2021	2022	2023	Average
Attica	504	6ML	Rh	67	66	60	33	59	57
Atwood	22248	2	Ur	8	8	5	5	9	7
Augusta	513	7M	Ew	9	14	8	10	11	10
Aurora	20287	7S	Ks	30	19	13	6	30	20
Axtell	536	7S	Ks	11	13	11	13	14	12
Baldwin	649	8M	Mc	16	38	13	12	10	18
Barber Co. RWD #01	34361	6S	Rh	NA	NA	NA	NA	NA	NA
Barber Co. RWD #02	15195	6S	Rh	41	40	43	45	44	43
Barber Co. RWD #03	15199	6S	Rh	37	40	38	41	32	38
Barnard	756	6S	Sr	14	12	NA	19	NA	15
Barnes	764	7S	Ks	4	4	4	8	0	5
Bartlett	54997	8S	Ne	27	36	34	47	NA	36
Barton Co. RWD #02	15196	6ML	Gb	NA	NA	NA	NA	NA	NA
Barton Hills Water District	33006	6S	Gb	4	2	6	3	3	4
Baxter Springs	933	8M	Ne	64	60	57	57	49	57
Bazine	943	4	Gb	7	15	14	10	19	13
Beattie	22016	7S	Ks	24	19	11	16	16	17
Bel Aire	25219	7M	Ew	2	15	NA	8	9	9
Belle Plaine	1098	7M	Ew	20	19	30	20	18	21
Belleville	1099	7M	Sr	12	1	8	9	5	7
Beloit	1100	6ML	Sr	NA	NA	NA	NA	7	7
Belpre	1101	5	Gb	14	11	22	11	8	13
Belvidere	6162	5	Rh	NA	NA	NA	NA	NA	NA
Belvue	1104	7S	Ks	NA	NA	1	NA	3	2
Bennington	1131	7M	Sr	27	32	18	15	17	22
Bentley	39238	7M	Ew	0	NA	NA	77	3	27
Benton	1147	7M	Ew	2	20	1	NA	1	6
Bern	1196	7S	Mo	NA	NA	1	5	2	3
Beverly	1250	6S	Ss	28	20	34	92	47	44
Bird City	1319	1	Ur	36	33	27	44	46	37
Bison	1350	5	Gb	17	14	9	12	9	12
Blue Rapids	1461	7M	Ks	30	NA	27	NA	27	28
Bluff City	1465	6S	Rh	NA	NA	43	NA	49	46
Bogue	1520	4	Sr	5	NA	NA	NA	NA	5
Bonner Springs	1572	8M	Mo	14	1	24	25	26	18
Bourbon Co. RWD #02C	34048	8M	Ne	21	22	27	NA	NA	23
Bourbon Co. RWD #04	20867	8M	Mc	12	34	21	15	8	18
Brewster	1909	2	Ur	NA	NA	20	7	NA	14
Bronson	1997	8S	Mc	9	7	7	7	6	7

Table 4: Unaccounted for water by public water supplier

Public Water Supplier	Person ID	GPCD Region ¹	Source Water RPA	Percent Unaccounted					Average
				2019	2020	2021	2022	2023	
Brown Co. RWD #01	15192	8M	Mo	30	20	34	20	32	27
Brown Co. RWD #02	38841	8M	Ks	14	3	18	24	17	15
Brownell	20981	4	Gb	12	1	1	1	1	3
Bucklin	2193	4	Ua	NA	5	15	7	21	12
Buffalo	2219	7S	Ve	16	14	18	18	12	15
Buffalo Hills Park	41252	5	Ss	26	18	9	11	20	17
Buhler	2224	6ML	Ew	11	13	4	6	4	8
Bunker Hill	2246	6S	Ss	3	5	3	4	3	3
Burden	2260	7M	Ew	8	7	5	1	4	5
Burdett	2264	5	Gb	0	15	7	21	1	9
Burlingame	2305	7M	Mc	10	14	52	54	10	28
Burlington	2306	7M	Ne	4	3	4	2	NA	3
Burns	2312	7S	Ew	3	15	7	8	10	9
Burr Oak	2317	6S	Sr	35	36	25	18	21	27
Burrton	2331	7M	Ew	10	20	14	13	11	14
Bushton	2350	6S	Gb	11	22	16	29	22	20
Butler Co. RWD #01	15191	7M	Ew	21	25	NA	35	NA	27
Butler Co. RWD #02	29224	7M	Ew	24	21	NA	20	NA	22
Butler Co. RWD #03	29226	7M	Ne	21	17	12	16	23	18
Butler Co. RWD #04	29233	7M	Ew	12	24	15	10	11	14
Butler Co. RWD #05	29227	7M	Ew	10	9	19	15	10	13
Butler Co. RWD #06	29228	7M	Ew	23	30	28	25	20	25
Butler Co. RWD #07	54998	7M	Ew	6	NA	20	20	25	18
Caldwell	32342	7M	Rh	18	22	28	26	24	24
Cambridge	2465	7S	Ew	NA	40	NA	44	NA	42
Caney	2504	7M	Ve	45	34	43	41	38	41
Canton	2512	7M	Ew	16	10	10	10	27	15
Carbondale	2521	7M	Ks	11	NA	NA	NA	NA	11
Cassoday	2644	7S	Ew	13	11	12	13	14	13
Cawker City	2673	6S	Sr	26	32	27	21	25	26
Cedar Point	34053	7S	Ne	2	5	15	NA	NA	7
Cedar Vale	2689	7M	Ve	14	14	15	4	15	13
Centralia	39511	7M	Ks	2	2	6	5	2	3
Chanute	2740	8M	Ne	15	11	11	17	20	15
Chapman	20907	7M	Ss	0	0	0	1	0	0
Chase	20834	6S	Gb	9	9	12	4	9	9
Chase Co. RWD #01	34363	7S	Ne	23	27	15	15	22	20
Chautauqua	54999	7S	Ve	23	22	32	NA	NA	26
Chautauqua Co. RWD #01	34459	7S	Ve	NA	NA	22	22	7	17

Table 4: Unaccounted for water by public water supplier

Public Water Supplier	Person ID	GPCD Region ¹	Source Water RPA	Percent Unaccounted					Average
				2019	2020	2021	2022	2023	
Chautauqua Co. RWD #02	35446	7S	Ve	27	24	20	16	NA	22
Chautauqua Co. RWD #03	40615	7S	Ve	8	0	5	5	NA	4
Chautauqua Co. RWD #04	61986	7S	Ve	9	21	NA	13	18	15
Cheney	2758	7M	Ew	4	1	11	0	4	4
Cherokee	2767	8M	Ne	2	7	3	4	4	4
Cherokee Co. RWD #01	15193	8M	Ne	32	40	27	31	40	34
Cherokee Co. RWD #02	15197	8M	Ne	33	27	26	27	27	28
Cherokee Co. RWD #03	15198	8M	Ne	43	50	58	57	48	51
Cherokee Co. RWD #04	15201	8M	Ne	44	43	47	47	49	46
Cherokee Co. RWD #05	32690	8S	Ne	26	23	NA	24	28	25
Cherokee Co. RWD #07	34434	8S	Ne	NA	33	45	NA	NA	39
Cherokee Co. RWD #08	32219	8M	Ne	23	16	22	NA	19	20
Cherokee Co. RWD #09	55013	8M	Ne	27	22	18	32	26	25
Chetopa	2773	8M	Ne	10	11	16	15	12	13
Chicopee Rural Water District	34257	8S	Ne	NA	4	3	6	NA	4
Chisolm Creek Utility Authority	56957	7S	Ew	17	16	13	3	0	10
Cimarron	2830	3	Ua	4	2	0	0	0	1
Circleville	34337	7S	Ks	11	9	5	NA	NA	8
Claflin	2857	6ML	Gb	19	19	8	14	18	16
Clay Center	2934	7M	Ks	9	8	8	9	13	9
Clay Co. RWD #01	15203	7S	Ks	14	10	14	18	18	15
Clay Co. RWD #02	22113	7M	Ss	24	26	28	12	NA	23
Clayton	2938	4	Sr	1	9	21	17	11	12
Clearview City	57736	8S	Ks	NA	NA	NA	NA	NA	NA
Clearwater	2939	7M	Ew	9	10	11	4	22	11
Clifton	2962	7M	Ks	17	21	25	22	25	22
Cloud Co. RWD #01	15204	7S	Sr	25	32	20	24	27	26
Clyde	2987	7M	Ks	29	24	28	21	13	23
Coal Hollow Water District	38417	8S	Ve	9	NA	NA	7	3	6
Coats	2992	6S	Gb	9	4	6	NA	NA	6
Coffey Co. RWD #02	22506	7M	Ne	13	15	11	15	NA	14
Coffey Co. RWD #03	33835	7M	Ne	12	12	13	9	8	11
Coffeyville	3018	7M	Ve	9	15	21	NA	10	14
Colby	3038	2	Ur	12	10	12	11	13	12
Coldwater	32341	5	Rh	12	14	6	16	18	13

Table 4: Unaccounted for water by public water supplier

Public Water Supplier	Person ID	GPCD Region ¹	Source Water RPA	Percent Unaccounted					Average
				2019	2020	2021	2022	2023	
Collyer	3096	4	Ss	1	5	12	11	NA	7
Colony	3098	8S	Ne	4	1	NA	16	NA	7
Columbus	3103	8M	Ne	19	16	19	10	9	15
Colwich	37973	7M	Ew	21	18	32	17	20	22
Comanche Co. RWD #01	34392	5	Rh	12	11	15	24	NA	15
Comanche Co. RWD #02	15211	5	Rh	15	3	30	33	37	24
Concordia	3122	7M	Sr	17	28	19	4	14	16
Conway Springs	3166	7M	Rh	3	18	NA	15	NA	12
Coolidge	3203	1	Ua	0	2	3	3	2	2
Copeland	3247	3	Ua	15	15	5	6	9	10
Corning	34298	7S	Ks	6	3	3	4	NA	4
Cottonwood Falls	3323	7M	Ne	2	10	6	0	0	4
Council Grove	3340	7M	Ne	27	32	15	20	16	22
Courtland	3351	7S	Sr	8	10	13	13	13	11
Cowley Co. RWD #01	15205	7M	Ew	10	10	9	12	15	11
Cowley Co. RWD #03	15218	7M	Ew	19	29	11	26	29	23
Cowley Co. RWD #04	34395	7M	Ew	3	19	22	1	38	16
Cowley Co. RWD #05	33722	7M	Ew	22	22	18	14	17	19
Cowley Co. RWD #06	15226	7M	Ew	8	22	19	15	21	17
Cowley Co. RWD #07	21282	7M	Ew	45	26	21	28	22	29
Cowley Co. RWD #08	41516	7S	Ew	41	NA	NA	8	7	18
Crawford Co. RWD #01	15206	8M	Mc	13	8	7	6	8	8
Crawford Co. RWD #01C	30949	8M	Mc	NA	30	29	44	22	31
Crawford Co. RWD #02	15212	8M	Ne	24	20	23	NA	NA	22
Crawford Co. RWD #03	15219	8S	Mc	4	6	18	7	11	9
Crawford Co. RWD #04	15221	8M	Ne	NA	14	11	14	16	14
Crawford Co. RWD #05	15224	8M	Ne	3	4	4	NA	12	6
Crawford Co. RWD #06	15227	8M	Ne	15	25	36	29	20	25
Cuba	3543	7S	Ks	30	15	16	10	9	16
Cullison	3553	6S	Gb	28	27	24	0	22	20
Culver	23878	7S	Ss	31	23	21	24	NA	25
Cunningham	3571	6S	Rh	25	20	25	20	15	21
Damar	3670	5	Sr	10	7	5	3	NA	6
Dearing	33938	7S	Ve	NA	NA	NA	8	NA	8
Deerfield	3893	2	Ua	14	10	13	16	17	14
Delia	33123	7S	Ks	18	12	23	14	NA	17
Delphos	3932	7S	Sr	15	14	13	12	10	13
Denison	34338	8S	Ks	7	13	11	7	9	10
Derby (El Paso Water Company)	33488	7L	Ew	NA	NA	3	6	3	4

Table 4: Unaccounted for water by public water supplier

Public Water Supplier	Person ID	GPCD Region ¹	Source Water RPA	Percent Unaccounted					Average
				2019	2020	2021	2022	2023	
DeSoto	3977	8M	Ks	21	15	17	20	22	19
Dexter	4021	7S	Ew	27	27	25	22	38	28
Dickinson Co. RWD #01	15207	7M	Ss	33	31	27	9	12	23
Dickinson Co. RWD #02	15213	7M	Ss	30	22	22	26	26	25
Dighton	4108	3	Us	3	9	NA	17	1	7
Dodge City	4207	4	Ua	1	3	1	1	1	1
Doniphan Co. RWD #03	15202	8M	Mo	17	9	8	19	7	12
Doniphan Co. RWD #05	23843	8M	Mo	21	26	NA	NA	NA	23
Doniphan RWD 06	61940	8S	Mo	20	8	NA	NA	NA	14
Dorrance	21622	6S	Ss	20	14	9	14	15	14
Douglas Co. RWD #01	15209	8M	Ks	23	26	29	28	NA	27
Douglas Co. RWD #02	15215	8M	Ks	8	13	5	11	NA	9
Douglas Co. RWD #03 (Tri-District Water System)	15220	8M	Ks	25	27	29	20	19	24
Douglas Co. RWD #04	55000	8M	Mc	6	7	6	9	11	8
Douglas Co. RWD #05	39221	8M	Mc	NA	18	14	12	16	15
Douglass	4304	7M	Ew	10	14	12	14	9	12
Downs	4336	6ML	Sr	9	1	8	10	14	9
Durham	4480	7S	Ne	18	26	34	13	12	21
Dwight	4511	7S	Ne	7	7	12	6	18	10
Easton	31979	8S	Mo	8	22	10	10	9	12
Edgerton	4610	8M	Ks	25	11	10	8	12	13
Edna	4619	8S	Ve	6	10	3	6	8	7
Effingham	4636	8M	Ks	13	19	8	8	13	12
El Dorado	4698	7L	Ew	1	2	2	NA	1	1
Elbing	55002	7S	Ew	13	5	8	7	8	8
Elgin	4708	7S	Ve	53	32	52	63	52	51
Elk City	4709	7S	Ve	3	4	1	4	44	11
Elk Co. RWD #01	34256	7S	Ve	26	24	30	29	27	27
Elk Co. RWD #02	63748	7S	Ve	21	21	37	17	16	22
Elkhart	4710	1	Ci	15	14	18	17	17	16
Ellinwood	4717	6ML	Gb	4	4	7	5	4	5
Ellis	4753	5	Ss	19	25	22	20	21	21
Ellis Co. RWD #01C	57485	5	Ss	NA	NA	NA	20	21	20
Ellis Co. RWD #03	20643	5	Ss	17	24	26	31	24	24
Ellis Co. RWD #06	15222	5	Ss	33	26	25	19	23	25
Ellsworth	4780	6ML	Ss	14	37	26	11	21	22
Ellsworth RWD #01	30564	6ML	Ss	15	15	12	16	11	14
Elmdale	34037	7S	Ne	27	1	7	62	58	31

Table 4: Unaccounted for water by public water supplier

Public Water Supplier	Person ID	GPCD Region ¹	Source Water RPA	Percent Unaccounted					Average
				2019	2020	2021	2022	2023	
Emmett	4812	7S	Ks	1	0	8	9	10	5
Emporia	4817	7L	Ne	27	18	20	25	29	24
Englewood	4853	4	Rh	39	51	58	31	36	43
Ensign	4871	3	Ua	11	6	NA	4	10	8
Enterprise	4882	7M	Ss	39	40	33	54	41	41
Erie	4908	8M	Ne	7	12	10	19	10	11
Esbon	4927	6S	Sr	22	20	39	29	33	29
Eskridge	26278	7M	Mc	6	4	3	7	6	5
Eudora	4974	8M	Ks	7	10	7	8	18	10
Eureka	4981	7M	Ve	9	8	9	9	8	9
Everest	5007	8S	Ks	20	17	16	15	8	15
Fall River	33228	7S	Ve	28	9	8	21	17	17
Finney Co. RWD #01	25245	2	Ua	4	10	9	3	2	5
Florence	5381	7S	Ne	12	26	33	23	20	23
Fontana	5403	8S	Mc	45	18	11	6	9	18
Ford	32601	4	Ua	NA	NA	23	3	17	14
Formoso	5429	6S	Sr	3	6	1	6	13	6
Fort Scott	5443	8M	Mc	10	6	11	24	15	13
Fowler	5489	3	Ci	23	26	23	NA	9	20
Frankfort	5566	7M	Ks	3	5	7	3	9	6
Franklin Co. RWD #01	21088	8M	Mc	5	11	13	14	13	11
Franklin Co. RWD #02	33669	8M	Mc	3	1	4	NA	8	4
Franklin Co. RWD #03	34185	8S	Mc	11	15	NA	6	NA	11
Franklin Co. RWD #04	15223	8M	Mc	7	10	7	9	8	8
Franklin Co. RWD #05	5568	8M	Mc	16	12	15	8	10	12
Franklin Co. RWD #06	5569	8M	Mc	25	26	21	17	26	23
Fredonia	5611	7M	Ve	29	25	37	33	32	31
Frontenac	5729	8M	Ne	11	12	11	9	9	10
Fulton	5776	8S	Mc	17	27	29	34	39	29
Galatia	57758	6S	Ss	NA	NA	NA	NA	NA	NA
Galena	5822	8M	Ne	56	48	66	37	49	51
Galesburg	5823	8S	Ne	10	12	25	3	2	10
Galva	5832	7S	Ew	10	0	0	5	3	4
Garden City	5855	2	Ua	3	1	4	3	3	3
Garden Plain	30142	7M	Ew	10	5	19	27	20	16
Gardner	5862	8L	Ks	19	18	12	16	16	16
Garnett	5890	8M	Mc	7	24	NA	26	24	20
Gas	34316	8M	Ne	6	5	8	5	8	6
Gaylord	5932	6S	Sr	13	8	1	NA	27	12
Geary Co. RWD #01	34329	7S	Ks	9	23	6	5	NA	11

Table 4: Unaccounted for water by public water supplier

Public Water Supplier	Person ID	GPCD Region ¹	Source Water RPA	Percent Unaccounted					
				2019	2020	2021	2022	2023	Average
Geary Co. RWD #02	37064	7S	Ks	NA	NA	NA	NA	NA	NA
Geary Co. RWD #04	22303	7M	Ks	4	3	4	3	5	4
Geneseo	5973	6S	Ew	29	34	24	11	28	25
Geuda Springs	6018	7S	Ew	19	24	20	29	20	22
Girard	6127	8M	Ne	59	59	33	26	22	40
Glade	6137	5	Sr	18	15	22	12	14	16
Glasco	6139	7S	Sr	18	26	21	NA	27	23
Glen Elder	6157	6S	Sr	11	NA	8	6	7	8
Goddard	6168	7M	Ew	4	14	13	14	12	11
Goessel	6219	7M	Ew	9	10	8	9	13	10
Goff	6233	7S	Ks	NA	NA	12	NA	5	8
Goodland	6270	1	Ur	12	13	16	15	11	14
Gorham	6302	6S	Ss	10	6	10	19	13	12
Gove	6332	3	Us	15	12	20	44	15	21
Grainfield	6383	3	Ss	NA	1	10	5	13	7
Grandview Plaza	6390	7M	Ks	NA	2	3	NA	2	2
Great Bend	23133	6ML	Gb	23	7	24	18	32	21
Greeley	6456	8S	Mc	3	5	5	1	3	3
Green	6463	7S	Ks	6	5	0	11	3	5
Greenleaf	6493	7S	Ks	23	2	5	6	6	8
Greensburg	6496	5	Gb	21	24	25	20	6	19
Greenwood Co. RWD #01	33858	7M	Ve	40	NA	NA	NA	NA	40
Greenwood Co. RWD #02	33859	7M	Ve	44	41	32	31	27	35
Greenwood Co. RWD #03	53335	7S	Ve	35	30	NA	8	7	20
Grenola	20856	7S	Ve	11	8	6	13	12	10
Gridley	6524	7S	Ne	7	20	25	16	9	15
Grinnell	6570	3	Ss	4	4	4	5	4	4
Gypsum	6666	7S	Ss	23	19	16	13	25	19
Haddam	6698	7S	Ks	28	36	41	53	58	43
Halstead	6801	7M	Ew	9	10	9	10	11	10
Hamilton	6807	7S	Ve	13	6	NA	20	NA	13
Hamilton Co. RWD #01	22258	1	Ua	7	8	5	26	19	13
Hanover	6904	7	Ks	NA	NA	NA	NA	NA	NA
Hanston	6934	4	Gb	9	2	19	3	-3	6
Hardtner	6957	6S	Rh	16	10	12	13	9	12
Harper	7022	6ML	Rh	14	12	20	17	12	15
Harper Co. RWD #01	34302	6S	Rh	4	-57	-5	0	NA	-14

Table 4: Unaccounted for water by public water supplier

Public Water Supplier	Person ID	GPCD Region ¹	Source Water RPA	Percent Unaccounted					Average
				2019	2020	2021	2022	2023	
Harper Co. RWD #02	33885	6S	Rh	13	13	19	NA	15	15
Harper Co. RWD #04	36758	6S	Rh	31	27	NA	28	NA	29
Harper Co. RWD #05	34303	6S	Rh	NA	6	NA	NA	NA	6
Harper RWD 03	7018	6S	Rh	NA	NA	NA	NA	NA	NA
Hartford	7088	7M	Ne	15	18	15	26	21	19
Harvey Co. RWD #01	34259	7M	Ne	14	7	12	11	10	11
Harveyville	7124	7S	Mc	NA	NA	3	NA	NA	3
Haven	7184	6ML	Ew	28	28	28	27	28	28
Havensville	7186	7S	Ks	3	NA	NA	3	NA	3
Haviland	7187	5	Gb	7	10	14	18	13	12
Hays	7227	5	Ss	12	11	7	12	12	11
Hays City Suburban Estates	7224	5	Ss	NA	NA	NA	NA	NA	NA
Haysville	7238	7L	Ew	16	10	18	16	18	16
Hazelton	7246	6S	Rh	54	12	17	10	10	21
Herington	7470	7M	Ss	15	12	11	29	17	17
Herndon	7491	2	Ur	5	2	4	1	1	3
Hesston	7561	7M	Ew	2	5	5	4	6	4
Hiawatha	7590	8M	Mo	19	20	14	22	13	17
Highland	7636	8M	Mo	16	12	14	15	15	14
Hill City	7652	4	Ur	11	8	10	11	8	10
Hillsboro	7699	7M	Ne	6	NA	6	15	3	8
Hillsdale Area Water Cooperative	65397	8L	Mc	0	NA	3	4	1	2
Hoag Water District	34270	8	Ne	NA	NA	NA	NA	NA	NA
Hoisington	7858	6ML	Gb	12	12	17	18	20	16
Holcomb	7861	2	Ua	15	16	15	14	6	13
Holton	21613	7M	Ks	10	11	10	9	11	10
Holyrood	7958	6S	Gb	3	4	9	9	10	7
Hope	8005	7S	Ss	38	8	6	32	14	20
Horace	8013	1	Us	4	6	7	7	3	5
Horton	8041	8M	Ks	27	23	15	27	NA	23
Howard	8100	7M	Ve	5	4	4	4	6	5
Howison Heights Water District	32822	7S	Ss	NA	NA	NA	NA	NA	NA
Hoxie	8123	3	Ur	15	15	16	16	17	16
Hoyt	55003	7M	Ks	14	20	16	22	NA	18
Hugoton	8223	2	Ci	16	12	15	22	22	17
Humboldt	8241	8M	Ne	21	2	5	16	12	11
Hunters Island: Riley County Public Work	64397	7S	Ks	1	2	NA	NA	NA	1

Table 4: Unaccounted for water by public water supplier

Public Water Supplier	Person ID	GPCD Region ¹	Source Water RPA	Percent Unaccounted					
				2019	2020	2021	2022	2023	Average
Hutchinson	8330	6ML	Ew	15	15	13	14	18	15
Independence	8379	7M	Ve	17	39	36	34	38	33
Ingalls	8384	3	Ua	NA	NA	NA	40	NA	40
Inman	8388	7M	Ew	12	9	4	2	7	7
Iola	8395	8M	Ne	24	26	22	23	23	23
Isabel	8436	6S	Rh	14	29	29	4	10	17
Iuka	33046	6S	Gb	NA	49	35	26	22	33
Jackson Co. RWD #01	23895	7M	Ks	16	11	12	13	14	13
Jackson Co. RWD #03	21090	7M	Ks	23	12	12	17	20	17
Jamestown	8540	7S	Sr	15	18	12	12	20	15
Jefferson Co. RWD #01	8627	8M	Ks	25	20	22	24	24	23
Jefferson Co. RWD #02	8628	8S	Ks	40	49	20	38	25	35
Jefferson Co. RWD #03	8622	8M	Ks	46	43	34	50	33	41
Jefferson Co. RWD #07	20800	8M	Ks	22	23	19	27	26	23
Jefferson Co. RWD #09	21091	8S	Ks	30	35	30	35	39	34
Jefferson Co. RWD #10	20750	8S	Ks	35	34	23	18	31	28
Jefferson Co. RWD #11	20752	8S	Ks	NA	4	9	19	10	10
Jefferson Co. RWD #12	20541	8M	Ks	24	23	23	21	19	22
Jefferson Co. RWD #13	21092	8M	Ks	32	27	14	13	18	21
Jefferson Co. RWD #15	21093	8S	Ks	18	13	29	45	36	28
Jennings	8647	3	Ur	32	30	62	27	22	35
Jetmore	8671	4	Gb	7	11	0	9	17	9
Jewell	8672	6S	Sr	12	21	20	22	19	19
Jewell Co. RWD #01	15281	6S	Sr	34	36	29	31	32	33
Johnson City	8719	1	Ua	17	15	11	8	14	13
Johnson Co. RWD #07	23910	8M	Ks	31	18	17	17	17	20
Junction City	8979	7L	Ks	37	30	26	31	26	30
Kanopolis	9033	6S	Ss	16	NA	NA	NA	11	13
Kanorado	9034	1	Ur	22	31	15	NA	17	21
Kansas City Board of Public Utilities	20297	8L	Ks	27	26	28	22	22	25
Kechi	35516	7M	Ew	4	9	NA	1	5	5
Kensington	9265	6S	Sr	31	21	26	21	28	25
Kingman	9404	6ML	Rh	9	2	2	3	8	5
Kingman Co. RWD #01	33775	6S	Rh	52	28	30	24	41	35
Kinsley	9417	5	Gb	14	16	22	21	7	16
Kiowa	9423	6ML	Rh	3	NA	NA	10	51	21
Kirwin	9468	5	Sr	9	12	25	14	15	15
Kismet	9474	2	Ci	17	15	19	18	19	17

Table 4: Unaccounted for water by public water supplier

Public Water Supplier	Person ID	GPCD Region ¹	Source Water RPA	Percent Unaccounted					Average
				2019	2020	2021	2022	2023	
Konza Valley Water District	41962	7S	Ks	NA	6	4	10	10	8
La Crosse	10038	5	Gb	17	19	25	33	37	26
La Cygne	10036	8M	Mc	31	25	26	17	9	22
La Harpe	33754	8S	Ne	25	27	32	28	35	29
Labette Co. RWD #01C	62649	8S	Ne	31	30	24	17	NA	25
Labette Co. RWD #03	55006	8S	Ve	13	12	13	13	8	12
Labette Co. RWD #06	23845	8M	Ve	3	23	41	41	11	24
Labette Co. RWD #07	55007	8M	Ne	NA	18	14	16	11	15
Labette Co. RWD #08	23846	8M	Ne	38	28	24	24	25	28
Labette RWD #04	34378	8	Ne	NA	NA	NA	NA	NA	NA
Labette RWD #05	34379	8M	Ne	NA	NA	NA	21	5	13
Lake Wabaunsee Improvement District	57322	7S	Mc	14	12	NA	NA	NA	13
Lakeside Village Improvement District	10062	8S	Ks	65	53	52	76	55	60
Lakin	10065	2	Ua	5	6	8	NA	NA	7
Lancaster	10103	8S	Ks	12	7	8	2	NA	7
Lane	10129	8S	Mc	24	6	7	13	13	12
Lane Co. RWD #01	20681	3	Us	19	10	8	9	12	12
Lansing (Lan-Del Water District)	34182	8M	Mo	2	3	4	1	2	2
Larned	10164	5	Gb	9	0	NA	4	20	8
Latham	10220	7S	Ew	17	27	18	22	25	22
Lawrence	10239	8L	Ks	7	6	5	4	5	5
Leavenworth	10277	8L	Mo	10	8	8	10	8	9
Leavenworth Co. RWD #01	34178	8M	Mo	NA	NA	NA	NA	3	3
Leavenworth Co. RWD #01C	15267	8M	Mo	7	11	7	7	NA	8
Leavenworth Co. RWD #02	34179	8M	Mo	38	27	NA	NA	NA	32
Leavenworth Co. RWD #05	34180	8M	Ks	16	NA	2	11	12	10
Leavenworth Co. RWD #06	33868	8M	Ks	29	17	NA	5	NA	17
Leavenworth Co. RWD #07	33869	8M	Ks	23	17	22	6	14	17
Leavenworth Co. RWD #08	34181	8M	Ks	15	10	8	NA	NA	11

Table 4: Unaccounted for water by public water supplier

Public Water Supplier	Person ID	GPCD Region ¹	Source Water RPA	Percent Unaccounted					Average
				2019	2020	2021	2022	2023	
Leavenworth Co. RWD #09	15276	8M	Ks	20	16	9	14	20	16
Leavenworth Co. RWD #10	34371	8M	Mo	13	12	20	14	9	14
Lebanon	10279	6S	Sr	29	23	17	18	11	20
Lebo	10280	7M	Mc	7	6	5	8	5	6
Lecompton	10287	8M	Ks	45	54	60	32	38	46
Lehigh	10317	7S	Ne	11	5	2	9	20	10
Lenora	10379	4	Sr	21	21	34	26	20	24
Leon	10381	7M	Ew	33	13	17	15	22	20
Leonardville	10399	7S	Ks	13	14	10	11	11	12
Leoti	10402	2	Us	9	7	12	12	5	9
LeRoy	10405	7M	Ne	11	18	6	7	82	25
Lewis	10437	5	Gb	NA	16	NA	21	8	15
Liberal	10482	2	Ci	NA	NA	NA	NA	NA	NA
Liebenthal	20452	5	Ss	21	18	24	NA	NA	16
Lincoln Center	10543	6ML	Ss	8	8	12	16	15	12
Lindsborg	10570	7M	Ss	6	9	7	6	5	6
Linn	10585	7S	Ks	9	9	6	0	2	5
Linn Co. RWD #01	33757	8M	Mc	33	38	8	NA	NA	26
Linn Co. RWD #02	34376	8M	Mc	NA	29	45	41	40	38
Linn Co. RWD #03	33758	8M	Mc	12	14	9	17	17	14
Linn Valley	65869	8M	Mc	39	35	36	32	17	32
Linwood	10595	8S	Ks	16	10	23	21	27	20
Little Bear Mound	38330	7S	Ve	NA	NA	NA	NA	NA	NA
Little River	10607	6ML	Ew	3	4	13	5	6	6
Logan	10655	5	Sr	11	8	14	9	13	11
Long Island	10681	5	Sr	NA	23	43	NA	NA	33
Longford	10693	7S	Ss	5	NA	2	1	17	6
Longton	10695	7S	Ve	35	36	11	14	12	22
Lorraine	10713	6S	Gb	27	25	16	14	9	18
Louisburg	10734	8M	Mc	19	17	19	12	17	17
Lucas	10790	6S	Ss	6	3	18	9	12	10
Luray	10838	6S	Ss	11	NA	10	1	0	6
Lyndon	10859	7M	Mc	10	10	11	10	6	9
Lyon Co. RWD #01	15230	7M	Mc	NA	NA	4	2	7	4
Lyon Co. RWD #02	23887	7M	Ne	8	3	NA	7	NA	6
Lyon Co. RWD #03	34166	7S	Ve	9	4	6	6	14	8
Lyon Co. RWD #05	34168	7M	Mc	9	10	17	14	15	13
Lyons	10864	6ML	Gb	8	2	8	9	4	6

Table 4: Unaccounted for water by public water supplier

Public Water Supplier	Person ID	GPCD Region ¹	Source Water RPA	Percent Unaccounted					Average
				2019	2020	2021	2022	2023	
Macksville	10889	6ML	Gb	NA	NA	NA	NA	NA	NA
Madison	10909	7M	Ve	15	15	14	24	18	17
Mahaska	10934	7S	Ks	2	4	2	10	6	5
Maize	22377	7M	Ew	10	12	8	NA	11	10
Manchester	10986	7S	Ss	NA	NA	NA	NA	NA	NA
Manhattan	10997	7L	Ks	9	9	12	10	6	9
Mankato	10999	6ML	Sr	56	50	53	45	41	49
Manter	11022	1	Ci	13	13	2	21	17	13
Maple Hill	11026	7M	Ks	9	9	12	13	12	11
Marais des Cygnes Public Utility Authority	58769	8L	Mc	10	12	13	13	13	12
Marion	11052	7M	Ne	21	19	28	27	32	25
Marion Co. Improvement District #02	51710	7S	Ne	2	2	2	2	4	2
Marion Co. RWD #01	15231	7M	Ss	36	26	35	28	28	31
Marion Co. RWD #02	55008	7S	Ne	7	3	4	NA	NA	5
Marion Co. RWD #04	23219	7M	Ne	21	19	13	14	NA	17
Marquette	11075	7M	Ss	12	0	13	15	14	11
Marshall Co. RWD #01	15232	7S	Ks	NA	NA	16	15	NA	15
Marshall Co. RWD #03	15261	7M	Ks	12	12	8	7	9	10
Marysville	11144	7M	Ks	20	15	14	16	20	17
Matfield Green	33118	7S	Ne	2	2	7	7	18	7
Mayetta	33072	7S	Ks	11	8	10	8	13	10
Mayfield	34417	7S	Rh	6	7	3	4	4	5
McCracken	32339	5	Ss	6	NA	15	2	2	7
McCune	11416	8S	Ne	8	16	13	1	15	11
McDonald	11436	2	Ur	29	21	1	17	43	22
McFarland	22114	7S	Ks	3	3	NA	NA	5	4
McLouth	11588	8M	Ks	9	10	14	NA	0	8
McPherson	11618	7L	Ew	7	7	8	4	1	6
McPherson Co. RWD #01	15233	7S	Ss	NA	NA	NA	9	1	5
McPherson Co. RWD #02	34332	7S	Ew	15	12	NA	12	10	12
McPherson Co. RWD #03	34333	7S	Ew	NA	NA	NA	NA	5	5
McPherson Co. RWD #04	34334	7M	Ew	13	7	6	10	5	8
McPherson Co. RWD #06	57737	7M	Ss	15	17	16	13	19	16

Table 4: Unaccounted for water by public water supplier

Public Water Supplier	Person ID	GPCD Region ¹	Source Water RPA	Percent Unaccounted					
				2019	2020	2021	2022	2023	Average
Meade	11636	3	Ci	24	23	23	25	27	25
Medicine Lodge	11663	6ML	Rh	10	10	15	13	9	11
Melvern	11736	7S	Mc	16	23	20	10	24	19
Miami Co. RWD #01	34426	8M	Mc	10	13	100	17	NA	35
Miami Co. RWD #02	15252	8L	Mc	8	7	9	16	14	11
Miami Co. RWD #03	34427	8M	Mc	29	34	38	42	38	36
Miami Co. RWD #04	36767	8M	Mc	NA	NA	13	8	14	12
Milford	11883	7M	Ks	8	NA	NA	NA	NA	8
Miller Enterprises Inc Of Garden City	50843	2	Ua	NA	NA	NA	NA	NA	NA
Miltonvale	12083	7S	Ss	8	1	3	8	5	5
Minneapolis	12094	7M	Sr	6	NA	20	7	23	14
Minneola	12095	4	Rh	6	4	10	5	8	6
Mitchell Co. RWD #02	15253	6ML	Ss	30	32	34	4	25	25
Mitchell Co. RWD #03	33397	6	Sr	NA	NA	NA	NA	NA	NA
Moline	12169	7S	Ve	18	15	12	11	7	13
Montezuma	12199	3	Ua	12	9	5	0	4	6
Montgomery Co. RWD #01	23847	7S	Ve	6	10	12	25	9	12
Montgomery Co. RWD #01C	55339	7M	Ve	26	NA	17	17	16	19
Montgomery Co. RWD #02	23848	7S	Ve	NA	NA	NA	NA	10	10
Montgomery Co. RWD #02C	61793	7M	Ve	NA	NA	NA	13	NA	13
Montgomery Co. RWD #06	55009	7M	Ve	NA	39	45	36	NA	40
Montgomery Co. RWD #08	23852	7S	Ve	NA	17	15	13	13	14
Montgomery Co. RWD #09	23853	7S	Ve	41	39	32	36	25	35
Montgomery Co. RWD #12	34326	7M	Ve	13	14	17	20	16	16
Montgomery Co. RWD #14	56883	7S	Ve	20	14	NA	NA	NA	17
Moran	12278	8M	Ne	18	11	13	14	19	15
Morganville	12308	7S	Ks	45	38	30	44	45	40
Morland	12319	4	Ur	3	13	12	NA	35	16
Morrill	12322	8S	Mo	23	15	9	4	NA	13
Morris Co. RWD #01	34865	7M	Ne	13	14	23	7	NA	14
Morrowville	12363	7S	Ks	4	4	5	3	4	4

Table 4: Unaccounted for water by public water supplier

Public Water Supplier	Person ID	GPCD Region ¹	Source Water RPA	Percent Unaccounted					
				2019	2020	2021	2022	2023	Average
Moscow	12380	2	Ci	26	26	22	17	13	21
Mound City	12429	8M	Mc	3	4	9	7	9	6
Mound Valley	12430	8S	Ve	17	9	11	8	10	11
Moundridge	12431	7M	Ew	3	2	NA	0	3	2
Mount Hope	12432	7M	Ew	31	15	7	9	10	14
Mulberry	12476	8M	Mc	23	21	21	21	19	21
Mullinville	20461	5	Gb	0	2	1	11	2	3
Mulvane	12492	7M	Ew	7	NA	NA	7	8	7
Munden	12497	7S	Ks	15	7	NA	NA	NA	11
Muscotah	12560	8S	Ks	29	9	9	26	45	24
Narka	12605	7S	Ks	NA	38	6	23	NA	22
Nashville	12607	6S	Rh	NA	NA	NA	NA	NA	NA
Natoma	12620	6S	Ss	17	16	11	25	22	18
Nemaha Co. RWD #01	15234	7S	Mo	18	17	16	9	9	14
Nemaha Co. RWD #03	15262	7M	Mo	11	4	4	3	2	5
Nemaha Co. RWD #04	34423	7M	Mo	17	11	20	12	11	14
Neodesha	12743	7M	Ve	8	11	8	12	13	10
Neosho Co. RWD #01C	55011	8M	Ne	NA	NA	NA	26	17	21
Neosho Co. RWD #02	15254	8M	Ne	39	40	43	32	32	37
Neosho Co. RWD #03	55010	8S	Ne	51	NA	NA	NA	7	29
Neosho Co. RWD #04	39323	8M	Ne	21	15	6	7	10	12
Neosho Co. RWD #08	34393	8S	Ne	19	24	16	14	22	19
Ness City	12744	4	Gb	8	9	21	8	9	11
Netawaka	34339	7S	Ks	8	7	5	5	4	6
New Strawn	12765	7S	Ne	14	10	18	7	7	11
Newton	12788	7L	Ew	12	11	10	8	10	10
Nickerson	12853	6ML	Ew	17	21	24	19	19	20
Nicodemus Township	12857	4	Ur	0	0	0	0	0	0
Norcatur	12973	3	Ur	4	8	6	7	5	6
North Newton	26573	7M	Ew	9	10	11	10	10	10
Norton	13015	4	Sr	19	22	19	14	19	19
Norton Co. RWD #01	15235	4	Sr	19	7	5	25	10	13
Nortonville	13022	8M	Ks	10	11	12	11	4	10
Norwich	13023	6S	Rh	21	8	12	18	26	17
Oakley	13097	2	Ur	13	20	19	11	20	17
Oberlin	13110	3	Ur	11	9	5	11	9	9
Offerle	13167	5	Gb	14	13	10	3	7	10
Ogden	13169	7M	Ks	4	20	15	NA	14	13
Oketo	13183	7S	Ks	1	2	14	NA	55	18
Olathe	13184	8L	Ks	16	12	12	16	15	14

Table 4: Unaccounted for water by public water supplier

Public Water Supplier	Person ID	GPCD Region ¹	Source Water RPA	Percent Unaccounted					
				2019	2020	2021	2022	2023	Average
Olmitz	20925	6S	Gb	9	19	23	25	27	21
Olpe	13210	7M	Ne	0	1	3	3	0	2
Olsburg	34885	7S	Ks	3	3	3	5	5	4
Onaga	13244	7M	Ks	3	4	9	8	3	6
Oneida	13245	7S	Mo	17	15	1	17	24	15
Osage City	13263	7M	Mc	5	3	4	3	3	4
Osage Co. RWD #02	15255	7S	Mc	14	13	6	7	8	10
Osage Co. RWD #03	15263	7M	Mc	20	12	10	15	3	12
Osage Co. RWD #04	15268	7M	Mc	25	8	7	15	22	15
Osage Co. RWD #05	15119	7M	Mc	13	14	13	12	13	13
Osage Co. RWD #06	40021	7S	Mc	18	24	24	23	NA	22
Osage Co. RWD #07	33876	7M	Mc	NA	13	15	26	27	20
Osage Co. RWD #08	55012	7M	Mc	NA	NA	NA	7	NA	7
Osawatomie	13264	8M	Mc	NA	NA	4	8	10	7
Osborne	13269	6ML	Sr	10	15	14	13	12	13
Osborne Co. RWD #01A	15249	6S	Sr	86	75	62	72	61	71
Osborne Co. RWD #02	25758	6S	Sr	20	18	17	15	9	16
Oskaloosa	13276	8M	Ks	18	3	8	13	7	10
Oswego	13299	8M	Ne	7	7	10	11	10	9
Otis	13300	5	Gb	1	2	1	3	6	2
Ottawa	13308	8L	Mc	NA	16	14	13	25	17
Ottawa Co. RWD #01	15282	7S	Sr	27	38	22	43	49	36
Ottawa Co. RWD #02	15256	7M	Sr	40	14	18	22	24	24
Overbrook	13323	7M	Mc	17	2	19	24	10	14
Oxford	13353	7M	Ew	7	9	6	NA	10	8
Ozawkie	13358	8M	Ks	17	38	9	28	1	18
Palco	13384	5	Sr	13	18	9	5	2	9
Palmer	13393	7S	Ks	35	3	10	13	6	13
Paola	13415	8M	Mc	16	11	14	15	12	14
Paradise	13419	6S	Ss	19	15	3	13	14	13
Park	13430	3	Ur	57	51	34	10	12	33
Park City	13427	7M	Ew	NA	11	24	23	17	19
Parsons	13488	8M	Ne	12	10	11	12	12	11
Pawnee Rock	31008	6S	Gb	14	16	18	27	19	19
Paxico	13551	7S	Ks	3	6	7	5	5	5
Paxton Addition	29202	1	Ur	NA	NA	NA	NA	NA	NA
Peabody	13561	7M	Ne	12	42	48	64	46	42
Perry	20928	8M	Ks	12	13	22	13	12	15
Peru	13688	7S	Ve	17	32	25	NA	NA	24
Phillips Co. RWD #01	15236	5	Sr	8	10	10	17	10	11

Table 4: Unaccounted for water by public water supplier

Public Water Supplier	Person ID	GPCD Region ¹	Source Water RPA	Percent Unaccounted					Average
				2019	2020	2021	2022	2023	
Phillipsburg	13808	5	Sr	20	10	11	7	7	11
Pittsburg	13876	8L	Ne	11	21	22	27	22	20
Plains	19243	3	Ci	23	18	22	15	21	20
Plainville	13883	5	Ss	5	NA	8	10	9	8
Pleasanton	13889	8M	Mc	11	16	13	14	13	13
Pomona	13946	8M	Mc	11	9	11	13	11	11
Portis	13980	6S	Sr	28	29	30	NA	20	27
Pottawatomie Co. RWD #01	15237	7M	Ks	31	20	31	NA	16	24
Pottawatomie Co. RWD #02	21005	7M	Ks	25	23	20	18	21	21
Pottawatomie Co. RWD #03	34075	7M	Ks	20	16	28	18	18	20
Pottawatomie Co. RWD #04	50614	7M	Ks	16	12	14	13	17	14
Potwin	14009	7S	Ew	1	2	18	8	6	7
Powhattan	33375	8S	Ks	NA	NA	NA	14	38	26
Prairie View	14043	5	Sr	6	4	3	3	5	4
Pratt	14050	6ML	Gb	11	12	10	10	10	10
Prescott	22619	8S	Mc	17	NA	NA	7	6	10
Preston	14074	6S	Gb	17	63	16	33	17	29
Pretty Prairie	14078	6ML	Ew	8	25	22	24	28	21
Princeton	14125	8S	Mc	75	67	NA	NA	NA	71
Protection	14152	5	Rh	18	22	13	17	21	18
Quenemo	14200	7S	Mc	NA	NA	NA	NA	NA	NA
Quinter	14220	3	Ur	10	NA	9	1	6	7
Randall	14294	6S	Sr	NA	28	13	61	26	32
Randolph	14309	7S	Ks	8	12	11	6	11	9
Ransom	14322	4	Ss	7	12	8	8	5	8
Rantoul	14323	8S	Mc	14	14	21	NA	6	14
Raymond	14383	6S	Gb	10	9	1	NA	NA	7
Reading	14386	7S	Mc	10	1	NA	NA	2	4
Red Bud Lake Improvement District	14391	7S	Ss	2	0	0	1	0	1
Reno Co. RWD #01	15238	6S	Ew	3	NA	3	9	5	5
Reno Co. RWD #03	15264	6ML	Ew	19	3	23	22	19	17
Reno Co. RWD #04	34153	6ML	Ew	11	5	NA	NA	NA	8
Reno Co. RWD #08	29055	6S	Ew	9	12	17	14	12	13
Reno Co. Water District #101	30458	6S	Ew	7	7	6	6	10	7
Republic	14580	7S	Sr	44	49	59	46	44	48

Table 4: Unaccounted for water by public water supplier

Public Water Supplier	Person ID	GPCD Region ¹	Source Water RPA	Percent Unaccounted					Average
				2019	2020	2021	2022	2023	
Republic Co. RWD #01	15239	7S	Sr	NA	54	59	51	50	53
Republic Co. RWD #02	15257	7M	Sr	37	35	40	37	42	38
Reserve	14589	8S	Mo	63	61	37	NA	22	46
Rexford	14597	2	Ur	7	7	7	8	7	7
Rice Co. RWD #01	40441	6ML	Ew	5	NA	8	NA	NA	6
Richmond	14683	8S	Mc	15	5	22	18	18	16
Riley	14753	7M	Ks	16	13	15	4	3	10
Riley Co. RWD #01	15240	7M	Ks	8	3	3	3	17	7
Robinson	14882	8S	Mo	18	27	13	2	NA	15
Rocky Ford Water Company	35916	7S	Ks	NA	NA	NA	NA	NA	NA
Rolla	14999	1	Ci	14	10	11	9	11	11
Rooks Co. RWD #01	15283	5	Sr	0	0	0	0	0	0
Rooks Co. RWD #02	15258	5	Ss	8	6	4	4	14	7
Rooks Co. RWD #03	15265	5	Sr	33	20	36	30	29	30
Rose Hill	15031	7M	Ew	NA	NA	11	22	11	14
Roseland	34296	8S	Ne	30	30	45	43	33	36
Rossville	15076	7M	Ks	6	2	8	NA	8	6
Rozel	15118	5	Gb	NA	6	3	12	21	11
Rush Center	15286	5	Gb	13	11	18	6	12	12
Rush Co. RWD #01	15241	5	Ss	29	34	27	20	20	26
Russell	15300	6ML	Ss	13	17	20	19	18	17
Russell Co. RWD #01	15242	6S	Ss	11	7	5	17	8	10
Russell Co. RWD #02	15259	6S	Ss	NA	NA	NA	NA	NA	NA
Russell Co. RWD #03	20482	6ML	Gb	38	26	19	26	14	25
Russell Co. RWD #04	15269	6S	Ss	51	45	38	16	44	38
Sabetha	15348	7M	Ks	10	13	2	8	10	9
Salina	15366	7L	Ss	13	9	7	10	14	11
Saline Co. RWD #01	15243	7S	Ss	2	2	9	9	5	5
Saline Co. RWD #02	15260	7S	Ss	62	27	40	42	49	44
Saline Co. RWD #03	34359	7M	Ss	9	15	2	4	14	9
Saline Co. RWD #04	15270	7M	Ss	28	11	15	15	33	20
Saline Co. RWD #06	15273	7S	Ss	32	12	13	9	4	14
Saline Co. RWD #07	35556	7S	Ss	14	13	26	18	5	15
Saline Co. RWD #08	50063	7S	Ss	42	24	NA	10	11	22
Satanta	15444	2	Ci	9	27	19	32	NA	22
Sawyer	15461	6S	Gb	8	8	8	6	6	7
Scammon	15474	8S	Ne	1	11	31	10	16	14
Scandia	15476	7S	Sr	3	2	NA	5	5	4
Schoenchen	61775	5	Ss	6	6	NA	9	10	8

Table 4: Unaccounted for water by public water supplier

Public Water Supplier	Person ID	GPCD Region ¹	Source Water RPA	Percent Unaccounted					
				2019	2020	2021	2022	2023	Average
Scott City	21022	2	Us	13	12	14	10	12	12
Scranton	16052	7M	Mc	NA	NA	3	9	9	7
Sedan	16086	7M	Ve	11	18	2	NA	4	9
Sedgwick	16088	7M	Ew	7	7	5	2	11	6
Sedgwick Co. RWD #01	24790	7M	Ew	8	10	10	23	NA	13
Sedgwick Co. RWD #02	23894	7M	Ew	NA	6	5	13	NA	8
Sedgwick Co. RWD #03	24791	7M	Ew	3	3	2	2	2	2
Sedgwick Co. RWD #04	26327	7M	Ew	1	9	10	14	17	10
Selden	16120	3	Ur	24	10	6	5	5	10
Seneca	16149	7M	Mo	NA	NA	NA	5	6	5
Severy	37790	7S	Ve	NA	23	NA	13	19	18
Sharon	16223	6S	Rh	11	22	NA	26	22	21
Sharon Springs	16222	1	Us	10	10	9	8	22	12
Shawnee Co. RWD #01C	23881	7M	Ks	6	5	7	6	5	6
Shawnee Co. RWD #02C	31683	7M	Ks	34	NA	17	NA	16	23
Shawnee Co. RWD #03C	58394	7M	Ks	14	10	9	6	11	10
Shawnee Co. RWD #04C	58395	7L	Ks	26	27	29	11	30	24
Shawnee Co. RWD #08	15275	7L	Ks	20	18	17	17	15	17
Silver Lake	16478	7M	Ks	10	9	9	6	6	8
Simmons Subdivision Sanitation System	60582	7S	Ew	9	NA	NA	NA	NA	9
Simpson	16521	6S	Sr	12	16	30	4	5	14
Smith Center	16631	6ML	Sr	39	35	31	36	33	35
Smith Co. RWD #01	24115	6S	Sr	21	19	19	18	15	18
Soldier	34340	7S	Ks	NA	NA	2	6	5	4
Solomon	16867	7M	Sr	25	15	5	12	11	14
South Haven	16878	7S	Rh	43	57	39	NA	19	39
South Hutchinson	16879	6ML	Ew	10	5	13	3	9	8
Spearville	16915	4	Ua	NA	8	10	12	10	10
Speed	16919	5	Sr	9	9	6	6	NA	7
Spivey	16977	6S	Rh	NA	NA	NA	NA	NA	NA
Spring Hill	20489	8M	Mc	12	14	12	14	16	14
St. Francis	17027	1	Ur	6	4	5	6	5	5
St. George	17028	7M	Ks	18	7	2	41	22	18
St. John	17029	6ML	Gb	10	32	14	8	13	15
St. Marys	17032	7M	Ks	7	18	10	17	0	11
St. Paul	17033	8M	Ne	26	21	72	71	29	44
Stafford	17056	6ML	Gb	7	7	14	16	17	12
Sterling	17250	6ML	Gb	5	4	6	5	7	5
Stockton	17320	5	Sr	25	7	23	22	11	17

Table 4: Unaccounted for water by public water supplier

Public Water Supplier	Person ID	GPCD Region ¹	Source Water RPA	Percent Unaccounted					Average
				2019	2020	2021	2022	2023	
Strong City	17454	7S	Ne	11	4	18	27	19	16
Sublette	17539	2	Ci	NA	9	14	9	10	11
Suburban Water Company	24951	8M	Ks	10	7	11	10	15	11
Summerfield	17582	7S	Mo	14	26	NA	11	23	18
Sumner Co. RWD #01	34418	7S	Ew	17	25	30	NA	31	26
Sumner Co. RWD #02	34419	7S	Ew	12	NA	10	4	NA	9
Sumner Co. RWD #03	34420	7S	Rh	NA	12	NA	17	0	14
Sumner Co. RWD #04	25252	7M	Ew	39	35	34	42	22	35
Sumner Co. RWD #05	24552	7M	Rh	10	13	16	22	30	18
Sumner Co. RWD #06	34318	7S	Ew	27	12	20	14	15	18
Sundowner Inc.	52848	7S	Ss	3	2	NA	NA	NA	2
Susank	55014	6S	Gb	NA	14	15	4	45	20
Sylvan Grove	17695	6S	Ss	8	14	19	7	8	11
Sylvia	17700	6S	Gb	52	NA	34	34	NA	40
Syracuse	17702	1	Ua	0	1	9	4	10	5
Tescott	17827	7S	Ss	13	15	24	17	26	19
Thayer	17839	8S	Ve	12	6	16	16	21	14
Timber Creek Water and Sewer District	36072	7M	Ks	12	7	6	7	6	8
Timken	18023	5	Gb	29	15	7	6	13	14
Tipton	18041	6S	Sr	5	3	7	6	3	5
Tonganoxie	18085	8M	Ks	15	15	14	13	13	14
Topeka	18096	7L	Ks	11	11	16	19	22	16
Toronto	18107	7S	Ve	1	7	NA	10	6	6
Towanda	18112	7M	Ew	9	NA	NA	NA	28	18
Trego Co. RWD #01	28343	4	Ss	47	1	32	10	12	20
Trego Co. RWD #02	36275	4	Ss	17	13	15	6	13	13
Tribune	18175	1	Us	2	2	1	1	2	1
Troy	18204	8M	Mo	5	9	16	6	7	9
Turon	18272	6S	Gb	11	7	11	5	5	8
Tuttle Creek Water Co.	36200	7S	Ks	24	19	NA	NA	NA	21
Two Lions Subdivision	16725	2	Ua	61	60	61	62	62	61
Udall	18307	7M	Ew	13	18	16	20	11	15
Ulysses	18327	2	Ua	12	7	8	6	8	8
Uniontown	18355	8S	Mc	8	9	9	7	6	8
University Park Water District	18363	7S	Ks	0	12	11	11	8	8
Utica	18454	4	Gb	0	40	40	25	41	29
Valley Center	18473	7M	Ew	1	NA	2	12	5	5

Table 4: Unaccounted for water by public water supplier

Public Water Supplier	Person ID	GPCD Region ¹	Source Water RPA	Percent Unaccounted					
				2019	2020	2021	2022	2023	Average
Valley Falls	18474	8M	Ks	18	20	20	27	19	21
Vermillion	22017	7S	Ks	5	8	1	3	9	5
Victoria	18587	5	Ss	9	13	6	10	5	9
Viola	18599	7S	Ew	4	5	2	6	NA	4
Virgil	21302	7S	Ve	13	9	20	11	NA	13
Wabaunsee Co. RWD #01	15244	7S	Ks	21	26	30	15	20	22
Wabaunsee Co. RWD #02	33095	7M	Ks	11	15	17	28	24	19
WaKeeney	18717	4	Ss	22	14	13	10	13	14
Wakefield	18718	7M	Ks	18	29	24	26	27	25
Waldo	18732	6S	Ss	1	1	0	0	0	1
Wallace	18794	1	Ss	2	2	4	1	4	3
Wallace Co. RWD #01	15245	1	Us	4	2	16	1	NA	6
Walnut	33755	8S	Ne	NA	NA	NA	NA	NA	NA
Walton	55500	7S	Ew	4	9	13	NA	15	10
Wamego	18859	7M	Ks	18	23	23	26	20	22
Washington	18929	7M	Ks	21	26	8	8	7	14
Washington Co. RWD #01	15246	7M	Ks	10	11	12	12	7	11
Washington Co. RWD #02	20337	7M	Ks	14	20	11	13	18	15
Water One - Johnson Co.	8693	8L	Mo	14	13	12	16	15	14
Waverly	18965	7M	Ks	11	2	2	3	4	5
Wathena	21969	8M	Mo	28	32	34	37	37	34
Waverly	18996	7M	Mc	16	13	11	17	13	14
Weir	19108	8M	Ne	7	12	18	22	11	14
Wellington	19136	7M	Rh	16	21	19	39	24	24
Wellsville	19154	8M	Mc	22	NA	11	NA	NA	17
West Hills Water Company	41680	6S	Ew	NA	NA	NA	NA	NA	NA
West Mineral	19242	8S	Ne	26	27	27	24	13	23
Westmoreland	19288	7M	Ks	9	3	7	11	13	9
Wetmore	19290	7S	Ks	16	15	22	16	15	17
White City	19348	7M	Ne	17	15	15	19	15	16
White Cloud	33077	8S	Mo	41	72	48	47	52	52
Whitewater	19409	7M	Ew	13	11	17	9	9	12
Whiting	19416	7S	Ks	8	11	15	23	NA	14
Wichita	19449	7L	Ew	7	6	16	15	90	27
Williamsburg	19628	8S	Mc	10	9	NA	7	9	9
Willis	34204	8S	Mo	NA	NA	11	27	15	18

Table 4: Unaccounted for water by public water supplier

Public Water Supplier	Person ID	GPCD Region ¹	Source Water RPA	Percent Unaccounted					Average
				2019	2020	2021	2022	2023	
Wilroads Garden Improvement	19647	4	Ua	NA	NA	NA	NA	NA	NA
Wilsey	56248	7S	Ne	4	NA	5	6	4	5
Wilson	20377	6ML	Ss	29	22	19	17	13	20
Wilson Co. RWD #01	33731	7S	Ve	22	17	12	14	14	16
Wilson Co. RWD #02	33732	7S	Ve	32	20	45	24	25	29
Wilson Co. RWD #04	34323	7S	Ve	0	14	22	15	26	15
Wilson Co. RWD #05	23885	7S	Ve	6	NA	12	9	7	8
Wilson Co. RWD #06	34324	7S	Ve	14	28	27	NA	NA	23
Wilson Co. RWD #07	33735	7S	Ve	22	24	18	16	19	20
Wilson Co. RWD #08	51703	7S	Ve	NA	NA	23	NA	40	31
Wilson Co. RWD #12	34325	7S	Ve	4	6	NA	NA	NA	5
Wilson Co. RWD #13	34529	7S	Ve	23	12	14	25	24	20
Wilson Lake Estates (Russell Co)	32937	6S	Ss	NA	NA	NA	NA	NA	NA
Winchester	19671	8M	Ks	NA	10	3	8	NA	7
Windom	38134	7S	Ew	31	23	NA	21	10	21
Winfield	19679	7L	Ew	7	9	10	8	10	9
Winona	19724	2	Us	22	25	21	11	18	19
Woodbine	40930	7S	Ss	NA	2	NA	NA	NA	2
Woodson Co. RWD #01	15247	7M	Ne	16	15	10	11	10	13
Woodston	19886	5	Sr	13	17	NA	NA	NA	10
Wright Improvement District	25906	4	Ua	NA	NA	NA	NA	NA	NA
Yates Center	19999	7M	Ne	14	15	16	17	11	14
Zenda	20148	6S	Rh	14	27	14	23	32	22

¹Large suppliers (L) serve 10,000 persons or more. Medium (M) suppliers serve 500 to 9,999 persons. Small (S) suppliers serve fewer than 500 persons; medium and large are combined for Region 6 because of the limited number of systems

Regions Used for Gallons per Capita per Day (GPCD) Analysis

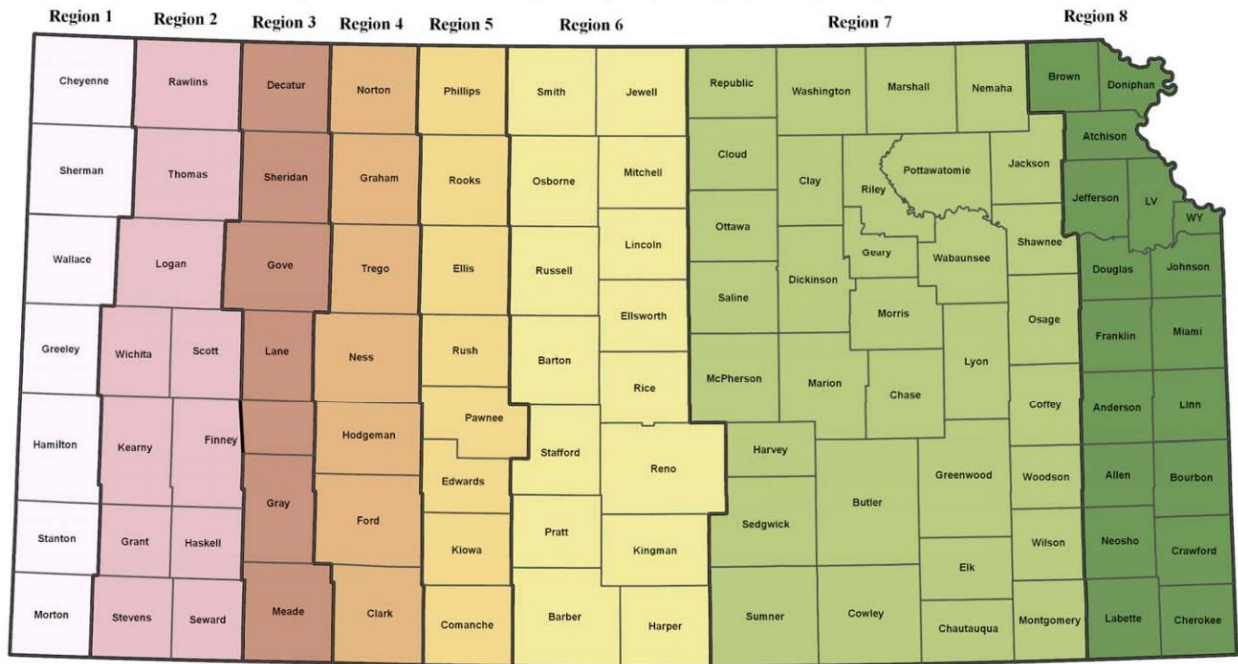

Figure 1: Regions used for gallons per capita per day (GPCD) analysis

Regional Planning Areas (RPA)

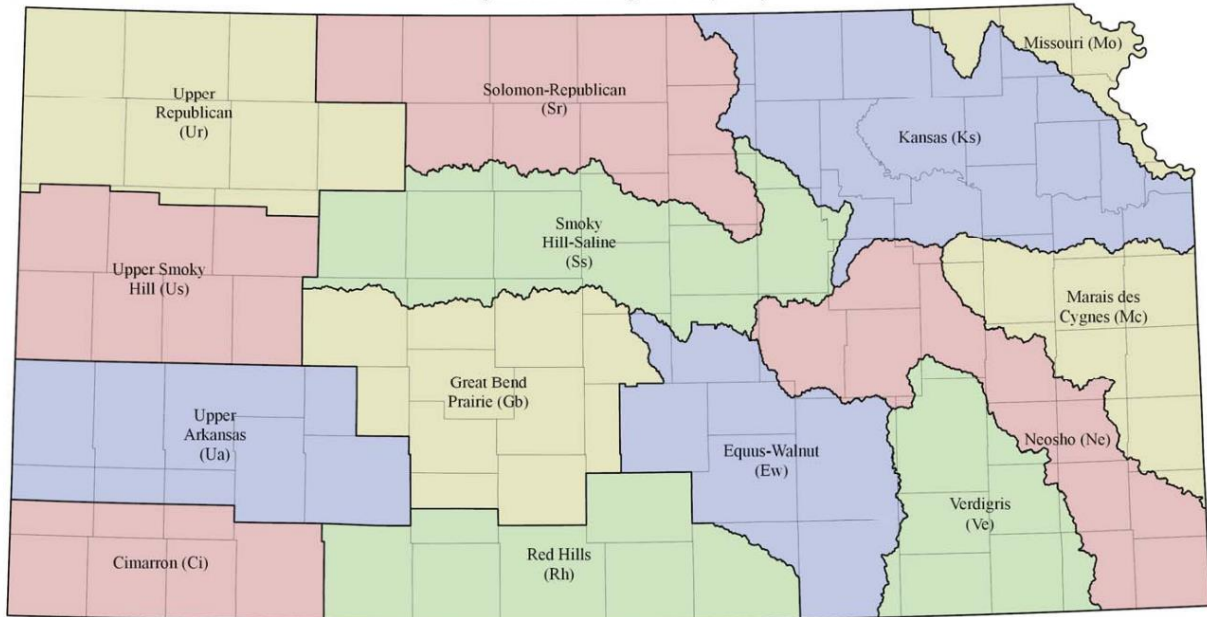

Figure 2: Regional Planning Areas of Kansas

Useful Links:

Kansas Department of Agriculture, Water Use Reporting:

<https://www.agriculture.ks.gov/divisions-programs/division-of-water-resources/water-appropriation/water-use-reporting>

Kansas Water Office, 2023 Kansas Municipal Water Conservation Plan Guidelines:

<https://www.kwo.ks.gov/home/showdocument?id=2276&t=638482570604530000>

Surplus Water Available in Water Marketing Program Lakes Calendar Year 2026



Table of Contents

INTRODUCTION	2
SURPLUS WATER AVAILABLE IN 2026	2
EXPLANATION OF YIELD CHANGES FROM CY 2025 SURPLUS REPORT	3
DROUGHT CONDITION CONTINGENCY	4
EXPLANATION OF RESERVOIR TABLES	4
INTERNAL POLICY MEMORANDUM #12	6
RESERVOIR SPECIFIC TABLES	8
<hr/>	
BIG HILL LAKE	9
CLINTON LAKE	11
COUNCIL GROVE LAKE	13
ELK CITY LAKE	15
HILLSDALE LAKE	17
JOHN REDMOND RESERVOIR	19
KANOPOLIS LAKE	21
MARION RESERVOIR	23
MELVERN LAKE	25
MILFORD LAKE	27
PERRY LAKE	29
POMONA LAKE	31
TORONTO LAKE	33
TUTTLE CREEK LAKE	35

Introduction

Surplus water is defined as waters within the conservation Water Supply capacity committed to the State, but not required to meet contractual requirements. Water in this storage may be sold under short term contracts if it is found to be surplus, is determined to be in the public interest, and if the contract will advance the purposes of the State Water Resource Planning Act.

This report for Calendar Year 2026, as approved by the Kansas Water Authority, constitutes the finding that the waters so indicated in the report are surplus (IPM-12).

The report will be used as guidance to the Director of the Kansas Water Office (KWO) in contracting for surplus waters for calendar year 2026. The surplus yield identified in this report is a starting point in determining whether the KWO should enter into a surplus water marketing contract. At the time an application for a surplus contract is submitted, the Director will also consider:

- Pending applications that are actively being pursued by an applicant which may result in water being committed to a user in the near future;
- The impact of the adopted lake level management plan;
- The existence of drought conditions and the effect of the drought on water in storage; and
- Any other information that could be used in the determination of the public interest.

Surplus Water Available in 2026

Statute limits the amount of water that can be provided as surplus water in any one calendar year to 10% of the water supply yield capability, unless the Governor has declared an emergency which affects the public, health, safety or welfare. Surplus Yield is the yield associated with Water Supply storage that is not committed to another user for that year. The Surplus Yield Available for Contract is the amount of Surplus Yield associated with in-service storage, limited to 10% of the Water Supply Yield. Additional limitations may be applied if the system model results indicate less yield than the individual reservoir models.

Summary Table

Lake	Water Supply Yield		Surplus Yield in 2026		Surplus Yield Available for Contract	
	mgd	Af/yr	mgd	Af/yr	mgd	Af/yr
Big Hill (Pearson-Skubitz)	7.9	8,837	6.6	7,442	0.8	884
Clinton	17.3	19,349	1.4	1,551	0.0	0
Council Grove	8.3	9,258	0.3	302	0.3	302
Elk City	13.3	14,923	8.5	9,496	1.3	1,492
Hillsdale	15.3	17,173	0.8	881	0.0	0
John Redmond	30.0	33,634	1.6	1,741	0.0	0
Kanopolis	8.0	8,993	2.8	3,089	0.8	899
Marion	4.0	4,445	2.3	2,581	0.4	444
Melvern	8.6	9,590	5.0	5,632	0.9	959
Milford	106.2	118,985	86.7	97,175	10.6	11,899
Perry	76.4	85,650	63.7	71,372	0.0	0
Pomona	7.6	8,488	5.0	5,602	0.8	849
Toronto	4.4	4,917	4.4	4,917	0.1	110
Tuttle Creek	160.6	180,063	27.8	31,153	16.1	18,006

Explanation of Yield Changes from CY 2025 Surplus Report

The primary difference between the water supply yields of this report and the previous year's report is due to the application of an additional year of sediment accumulation in each reservoir. The annual sedimentation rate at each reservoir is published online by the KWO and establishes the annual volumetric reduction to the reservoirs listed in this surplus report. New bathymetric surveys may reveal changes to the historic sedimentation rates. In addition to the impact of annual sediment accumulation on yield, reservoir operational changes can impact yield. Additionally, KWO strives to use the best available information in the yield models and model data revisions are necessary from time to time. The changes from 2025 to 2026 are summarized in the table below.

Yield Changes From 2025 Surplus Report				
Lake	2025 Yield (MGD)	2026 Yield (MGD)	% Change from 2025	Comment
Big Hill (Pearson-Skubitz)	7.9	7.9	-0.2%	
Clinton	17.3	17.3	0.0%	
Council Grove	8.2	8.3	1.0%	Updated 2024 survey
Elk City	13.1	13.3	1.2%	Updated 2024 survey
Hillsdale	15.3	15.3	-0.1%	
John Redmond	30.2	30.0	-0.7%	
Kanopolis	8.2	8.0	-2.2%	
Marion	5.0	4.0	-20.7%	Updated 2024 survey
Melvern	8.6	8.6	-0.1%	
Milford	106.8	106.2	-0.6%	
Perry	76.7	76.4	-0.4%	
Pomona	7.6	7.6	-0.6%	
Toronto	4.4	4.4	-1.1%	
Tuttle Creek	162.0	160.6	-0.9%	
Yields units are million gallons/day (MGD)				

Below: Reservoir volumes from initial construction to most recent survey, with projected 2026 volumes.

Reservoir Name	Initial Year	Initial Storage (AF)	Most Recent Survey	Most Recent Survey Storage (AF)	Historical Average Annual Sedimentation Rate - Since Initial Year (AF)	Projected 2026 Storage (AF)
Kanopolis	1946	73,187	2017 *	47,156	364	43,745
Milford	1967	415,403	2020	357,186	1,082	350,536
Tuttle Creek	1962	425,312	2020	225,825	3,412	204,565
Perry	1969	243,261	2021	189,958	1,007	184,942
Hillsdale	1981	82,207	2022	75,851	156	75,162
Clinton	1975	129,171	2019 *	111,842	413	108,901
Elk City	1966	52,261	2024	34,399	307	33,650
John Redmond	1963	102,254	2023	59,016	723	56,497
Marion	1968	84,948	2024	76,837	144	76,477
Council Grove	1965	52,736	2024	42,543	173	42,111
Fall River	1948	30,401	2009 *	20,643	158	18,117
Toronto	1960	27,320	2010 *	16,528	215	13,224
Big Hill	1981	27,215	2010 *	23,361	132	21,226
Pomona	1963	70,603	2024	50,354	334	49,524
Melvern	1972	154,370	2017	147,972	142	146,624

* New survey has been conducted, awaiting data processing or delivery

Drought Condition Contingency

The Kansas Water Office has the statutory responsibility to advise the Governor on drought conditions and coordinates the Governor's drought response team. The Drought Monitoring Program collects climate data from a variety of sources, monitors drought activities and publishes a drought report during periods of drought. **The impact of drought conditions on reservoir storage will be evaluated at the time a surplus contract is being considered. Prior to entering into a surplus contract, the KWO will review current drought conditions, declarations and forecasts. Conditions that may warrant declining a new surplus contract include: extended below normal precipitation; below normal streamflow in the river basin; concern about percent of storage remaining in the conservation pool and low probability of refill based on historic record.**

Explanation of Reservoir Tables

Table 1 - Conservation Storage Break Out

Table 1 for each reservoir separates the conservation storage into various components. The conservation storage is used for multiple purposes, which are identified in Table 1 and the pie charts as Water Quality, Other/Local and Water Supply.

The Water Quality pool is utilized to make established minimum releases which are intended to maintain flow in the stream below the lake. The U.S. Army Corps of Engineers (USACE) retains ownership of this storage.

The Other/Local pool includes storage that has been contracted by the USACE to a local water supplier and storage that has been retained by the USACE.

The Water Supply pool includes the amount of storage the State has under contract to serve the needs of municipal or industrial users' long-term needs. The Water Supply pool is further divided into an In-Service portion and a Future Use portion. Some of the water supply contracts between the USACE and the Kansas Water Office allow the State to defer payment on storage until the storage is needed. When the storage is being paid for it is considered In Service. The USACE retains ownership of the Future Use storage until the State calls that storage into service.

The In-Service Water Supply is then further divided by how that storage has been and is being paid for. Water Marketing is the amount of committed storage to serve the customers of that program. Water Assurance is the amount of storage owned by the municipal and industrial users below lakes that have formed a Water Assurance District. The Reserve Capacity is storage the State purchased and is not currently needed for either the Water Marketing or Water Assurance programs. Annual operation and maintenance costs of the Reserve Capacity are paid by the State Water Plan Fund.

Table 1 provides the breakout of the conservation storage in percentage of the current total conservation pool and in current estimated acre-feet, which is based on a projection using the most recent sediment survey. The amount of water the Water Supply storage can yield during a 2% drought is also provided. The drought from 1952 through 1957 is defined in regulations as a 2% drought.

Table 2 - Contracted Quantities

Table 2 lists data associated with existing water marketing contracts for each lake. Table 2 provides the annual maximum quantity of water for each contract as well as the amount of water committed to each customer in 2026. Statute allows for a contract holder to negotiate a contract for an amount of water which gradually increases over time. The difference between the 2026 maximum quantity and the annual maximum quantity is a portion of the water available for surplus.

Table 3 - Pending Applications

Table 3 lists pending applications for water marketing contracts for each lake. The Water Marketing Program allows applications to remain on file for up to 13 years without beginning negotiations for a contract. Thus, some applications will not result in long term contracts in 2026. This information will be reviewed by the Director at the time a surplus application is submitted.

Table 4 - Past Surplus Contracts

Table 4 lists the surplus Water Marketing contracts for the past two years for each lake.

Table 5 - Surplus Yield

This table lists the yield that is determined to be surplus in 2026. Storage owned by a Water Assurance District and water committed to a Water Marketing customer in 2026 is not available for surplus contracts. Thus, the yield committed through Marketing contracts and the yield associated with the portion of the Water Supply pool owned by a Water Assurance District is subtracted from the estimated 2026 yield. Additionally, the portion of the Water Supply pool considered Future Use Storage is controlled by the USACE and is not available for a surplus water marketing contract. When there is Surplus Yield, the amount of Surplus Yield Available for use during the calendar year is limited to 10% of the Current Yield or the calculated Surplus Yield, whichever is less.

Calculation of Surplus Yield Available (*example*):

mgd	AF/yr	
10	11,201	Current Yield
- 2	2,240	Marketing Contracts
- 3	3,360	WAD Storage Yield
- 3	3,360	Future Use Yield
2	2,240	Surplus Yield
1	1,120	Surplus Yield Available

Lake Level Management Considerations

The KWO is charged by the State Water Planning Act with negotiating and entering into agreements with the USACE and the U.S. Bureau of Reclamation regarding operation or releases of water from federal projects. Seasonal lake levels are developed annually and are known as Lake Level Management Plans. Development of these plans includes public and stakeholder input. They are intended to increase the benefits to recreational users and improve wildlife and aquatic habitat while protecting the flood control, water supply and water quality purposes of the lake. It is important to note that the plans are developed for average climate conditions.

Most plans include additional flood storage for high springtime flows but flood operation procedures are followed as specified in the regulation manual. Drought conditions may also warrant deviation from the plan. Large volumes of water are stored or evacuated as the seasonal pool elevation changes. Protection of Water Supply storage is essential and statutory limitations are in place for this purpose. Water from the Water Quality and Water Supply pools may be evacuated during a lake level operation; however, the amount of water evacuated from the Water Supply pool under a lake level management operation is limited to the surplus yield available.

Internal Policy Memorandum #12

KANSAS WATER AUTHORITY

901 South Kansas Avenue, Topeka, KS 66612-1249 (785) 296-3185

Steve Irsik, Chairman

5405 Six Road, Ingalls, KS 67853

(620) 335-5363 - steve@ucom.net



IPM-12
Adopted April 7, 2006

MEMORANDUM OF INTERNAL POLICY

Disposal of Surplus Water in the State's Conservation Water Supply Capacity

Background

The Kansas Water Authority shall authorize the director of the Kansas Water Office to dispose of water when the Authority finds

1. the water is determined to be surplus,
2. it is in the public interest to dispose of the water, and
3. such disposal will advance the purposes of the State water resource planning act.

Surplus water is defined as waters within the conservation water supply capacity committed to the State, but not required to meet contractual requirements. K.S.A. 82a-1305(b) addresses disposal of surplus water.

82a-1305. (b) Whenever the authority finds that it is in the public's interest and will advance the purposes set forth in this act and in article 9 of chapter 82a of Kansas Statutes Annotated, and amendments thereto, the authority shall authorize the director to dispose of waters found by the authority to be surplus waters. Any arrangement for the disposition of any such surplus waters shall not be subject to the provisions of K.S.A. 82a-1306, 82a-1307 and 82a-1308a, and amendments thereto, relating to long-term contracts. No such arrangement shall be made for a period of time in excess of one year nor shall any such arrangement dispose of water from the conservation water supply capacity in excess of 10% of the yield capability as computed pursuant to subsection (a) unless the governor has declared that an emergency exists which affects the public health, safety or welfare. No charges shall be levied on the disposition of surplus waters when the purpose for such disposition is streamflow maintenance or reservoir pool management. A charge at a rate not to exceed the rate established pursuant to K.S.A. 82a-1306, and amendments thereto, shall be levied on the disposition of surplus waters when the purpose of such disposition is the maintenance of public health. A charge at a rate that may exceed the rate established pursuant to K.S.A. 82a-1306, and amendments thereto, shall be levied on the disposition of surplus waters when the purpose for such disposition is other than streamflow maintenance, reservoir pool management or maintenance of public health. History: L. 1974, ch. 452, § 5; L. 1976, ch. 441, § 2; L. 1977, ch. 358, § 1; L. 1983, ch. 343, § 4; L. 1984, ch. 382, § 2; L. 1986, ch. 396, § 4; July 1.

Process and Criteria

At the last Kansas Water Authority meeting of each calendar year, the Kansas Water Office will report to the Authority the following:

1. available surplus water within the State's water conservation storage capacity by reservoir for the following calendar year,
2. pending applications and on-going negotiations of water marketing contracts,
3. anticipated uses of the surplus water, including anticipated water marketing surplus contracts, streamflow maintenance needs and lake level management plans, and
4. assessment of any drought that may be occurring in the State and potential impacts of the drought on storage.

Approval of the report by the Authority will constitute a finding that the waters so indicated in the report are surplus, that it is in the public interest to dispose of the surplus waters, and disposal will advance the purposes of the State water resource planning act. The report will guide the director of the Kansas Water Office in disposing of surplus waters for the following calendar year, including entering into surplus water marketing contracts.

Because the yield capability of each reservoir's water conservation storage, referred to in K.S.A. 82a-1305(a), is projected into the future forty years per K.A.R. 98-5-8(a)(4) and the annual report of disposal of surplus water will utilize yield data associated with the following calendar year, the disposal of surplus water will be limited to the amount of storage that allows 90% of the "yield capability as computed pursuant to subsection (a)" to remain in storage for the following calendar year.

Date: June 2, 2006

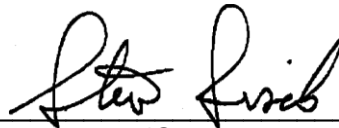

Steve Irsik, Chairman
Kansas Water Authority

Reservoir Specific Tables



Big Hill Lake

Table 1: Conservation Storage Break Out

Conservation Pool Elevation (ft msl)	814 - 858	Flood Pool Elevation (ft msl)	858 - 867.5
	Break Out of Conservation Storage	Current Yield (mgd)	Current Storage (acre feet)
Water Quality	0.00%	0	0
Other/Local	0.00%	0	0
Water Supply	100.00%	7.9	21,226
Future Use	64.20%	5.1	13,626
In Service	35.81%	2.8	7,600
Water Marketing	35.81%	2.8	7,600
Assurance District	0.00%	0	0
Reserve Capacity	0.00%	0	0

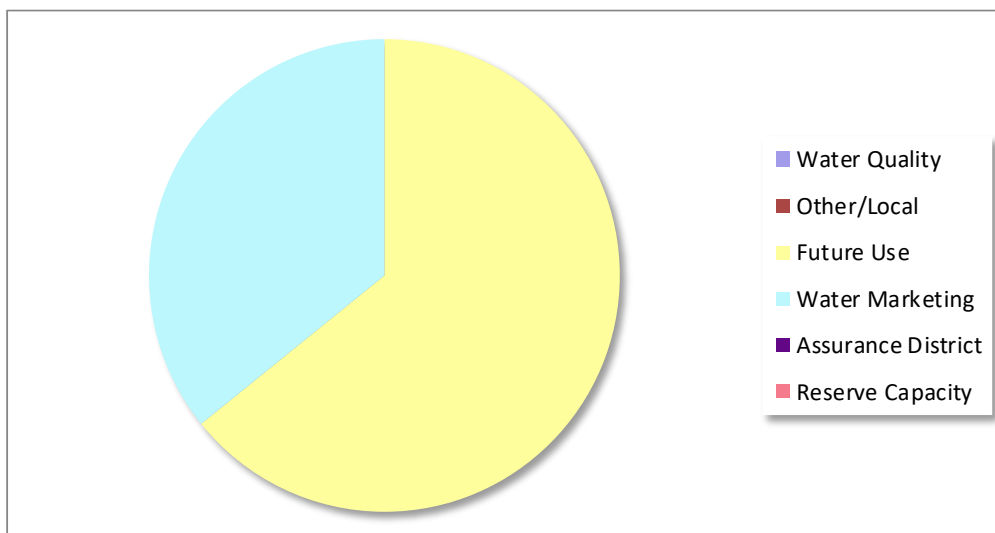

Table 2: Contracted Quantities

Contract Number	Customer Name	Contract End Date	2026 Maximum Gallons	2026 Maximum AF	Annual Contract Maximum Gallons	Annual Contract Maximum AF
98-1	Public Wholesale Water Supply Dist. No. 4	4/17/2038	454,700,000	1,395	454,700,000	1,395
			454,700,000	1,395	454,700,000	1,395

Table 3: Pending Applications

Applicant Name	Application Expiration Date	Requested Quantity Gallons	Requested Quantity AF
There are no pending applications on file			

Table 4: Past Surplus Contracts

Contract Number	Customer Name	Contract End Date	Annual Contract Maximum Gallons	Annual Contract Maximum AF
There were no surplus contracts in the past two years				

Table 5: Surplus Yield

mgd	AF/yr	
7.9	8,837	Current Yield
1.2	1,395	Marketing Contracts
0	0	WAD Storage Yield
5.1	5,673	Future Use Yield
1.6	1,769	Surplus Yield
0.79	884	Surplus Yield Available

Lake Level Management Consideration

No Lake Level Management Plan was prepared for Big Hill for Water Year 2026.

Clinton Lake

Table 1: Conservation Storage Break Out

Conservation Pool Elevation (ft msl)	840 - 875.5	Flood Pool Elevation (ft msl)	875.5 - 903.4
	Break Out of Conservation Storage	Current Yield (mgd)	Current Storage (acre feet)
Water Quality	19.20%	0	21,428
Other/Local	0.00%	0	0
Water Supply	80.80%	17.3	90,178
Future Use	32.30%	6.9	36,049
In Service	48.50%	10.4	54,129
Water Marketing	48.50%	10.4	54,129
Assurance District	0.00%	0	0
Reserve Capacity	0.00%	0	0

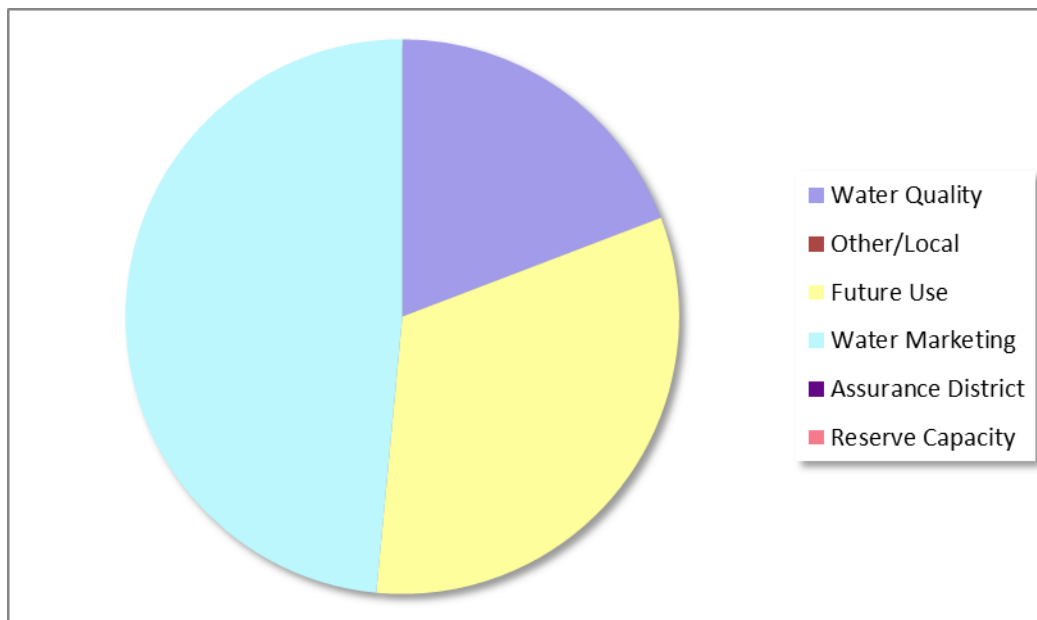

Table 2: Contracted Quantities

Contract Number	Customer Name	Contract End Date	2026 Maximum Gallons	2026 Maximum AF	Annual Contract Maximum Gallons	Annual Contract Maximum AF
95-3	Douglas County Rural Water District No. 5	10/26/2035	128,298,541	394	128,298,541	394
19-1	City of Lawrence	12/29/2059	4,988,000,000	15,308	4,988,000,000	15,308
21-2	Douglas County Rural Water District No. 3	12/13/2041	650,000,000	1,995	650,000,000	1,995
21-4	Douglas County Rural Water District No. 6	12/13/2041	33,200,000	102	33,200,000	102
			5,799,498,541	17,798	5,799,498,541	17,798

Table 3: Pending Applications

Applicant Name	Application Expiration Date	Requested Quantity Gallons	Requested Quantity AF
There are no pending applications on file			

Table 4: Past Surplus Contracts

Contract Number	Customer Name	Contract End Date	Annual Contract Maximum Gallons	Annual Contract Maximum AF
There were no surplus contracts in the past two years				

Table 5: Surplus Yield

mgd	AF/yr	
17.3	19,349	Current Yield
15.9	17,798	Marketing Contracts
0	0	WAD Storage Yield
6.9	7,735	Future Use Yield
0.0	0	Surplus Yield
0.0	0	Surplus Yield Available

Lake Level Management Consideration

According to the Lake Level Management Plan, this year is following the Wildlife Plan.

Clinton Lake
 Conservation Pool = 875.5 Flood Pool (FP) = 903.4 5% into FP = 877.4

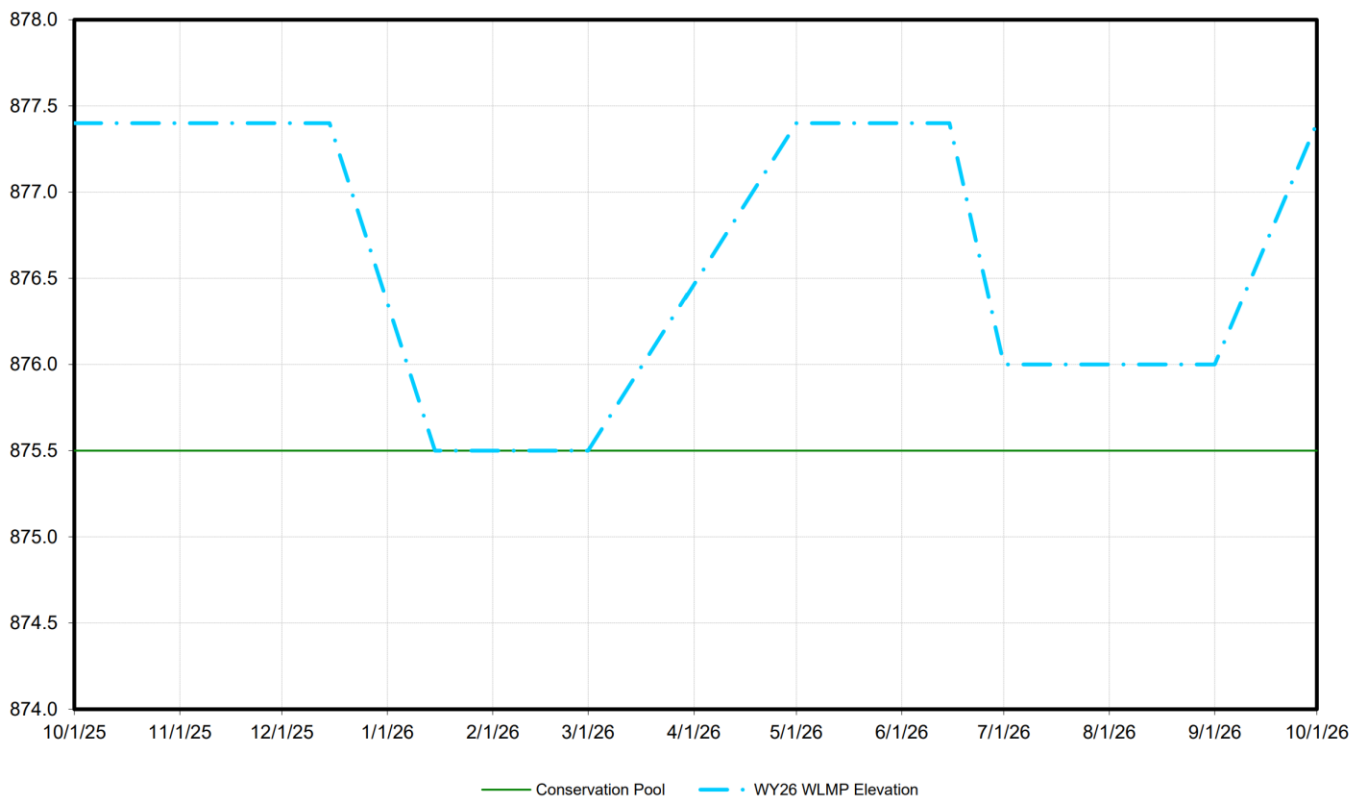

Council Grove Lake

Table 1: Conservation Storage Break Out

Conservation Pool Elevation (ft msl)	1240 - 1274	Flood Pool Elevation (ft msl)	1274 - 1289
	Break Out of Conservation Storage	Current Yield (mgd)	Current Storage (acre feet)
Water Quality	22.67%	0	9,156
Other/Local	0.00%	0	0
Water Supply	77.33%	8.2	31,232
Future Use	0.00%	0.0	0
In Service	77.33%	8.2	31,232
Water Marketing	62.53%	6.6	25,255
Assurance District	14.80%	1.6	5,978
Reserve Capacity	0.00%	0.0	0

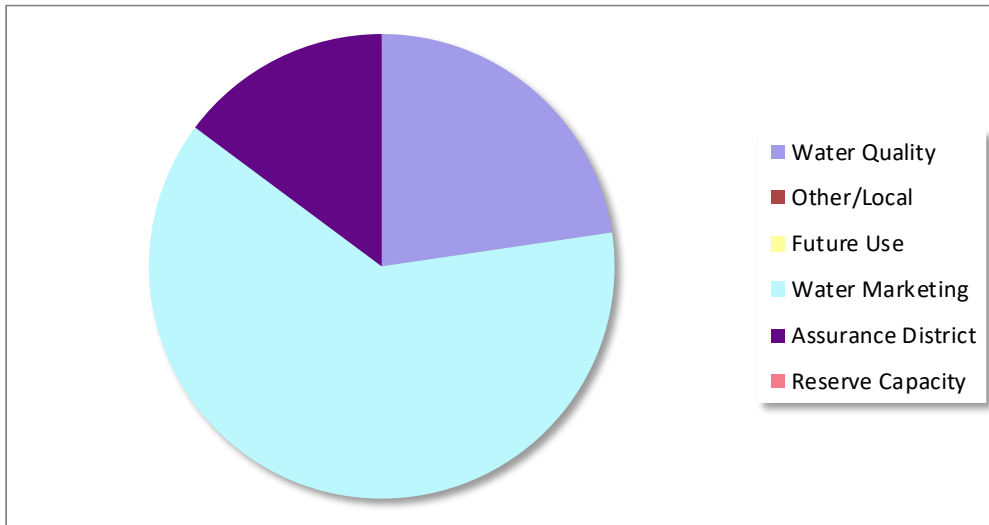

Table 2: Contracted Quantities

Contract Number	Customer Name	Contract End Date	2026 Maximum Gallons	2026 Maximum AF	Annual Contract Maximum Gallons	Annual Contract Maximum AF
23-5	City of Emporia	12/31/2045	2,280,958,000	7,000	2,280,958,000	7,000
93-4	City of Council Grove	9/13/2033	60,000,000	184	150,000,000	460
			2,340,958,000	7,184	2,430,958,000	7,460

Table 3: Pending Applications

Applicant Name	Application Expiration Date	Requested Quantity Gallons	Requested Quantity AF
No pending applications			

Table 4: Past Surplus Contracts

Contract Number	Customer Name	Contract End Date	Annual Contract Maximum Gallons	Annual Contract Maximum AF

Table 5: Surplus Yield

mgd	AF/yr	
8.3	9,258	Current Yield
6.4	7,184	Marketing Contracts
1.6	1,772	WAD Storage Yield
0.0	0	Future Use Yield
0.3	302	Surplus Yield
0.27	302	Surplus Yield Available

Lake Level Management Consideration

According to the Lake Level Management Plan, pool level may be lowered in January (or prior to freezing).

Council Grove Lake
 Conservation Pool = 1274.0 Flood Pool (FP) = 1289.0 5% into FP = 1275.0

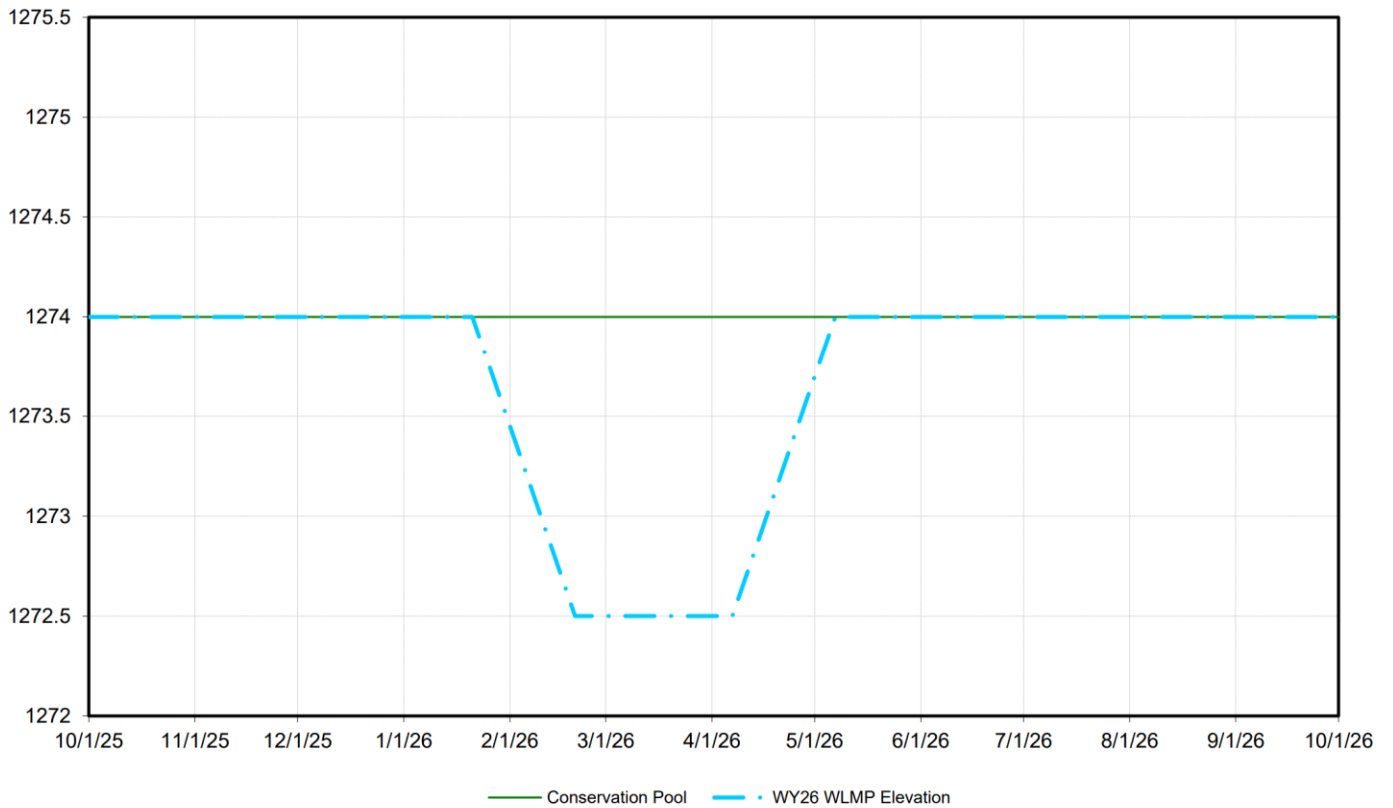

Elk City Lake

Table 1: Conservation Storage Break Out

Conservation Pool Elevation (ft msl)	764 - 796	Flood Pool Elevation (ft msl)	796 - 825
	Break Out of Conservation Storage	Current Yield (mgd)	Current Storage (acre feet)
Water Quality	14.08%	0	4,728
Other/Local	0.00%	0	0
Water Supply	85.92%	13.3	28,852
Future Use	0.00%	0.0	0
In Service	85.92%	13.3	28,852
Water Marketing	57.45%	8.9	19,292
Assurance District	0.00%	0.0	0
Reserve Capacity	28.47%	4.4	9,560

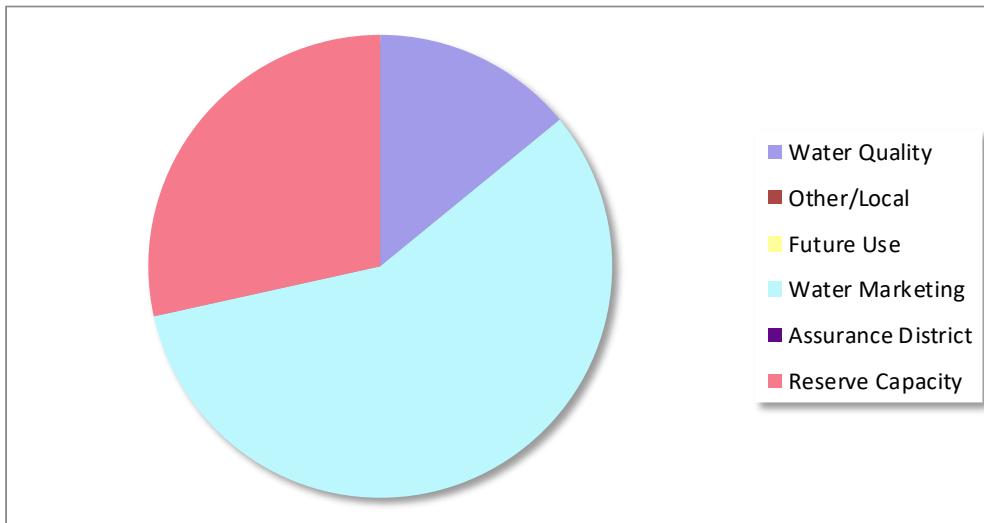

Table 2: Contracted Quantities

Contract Number	Customer Name	Contract End Date	2026 Maximum Gallons	2026 Maximum AF	Annual Contract Maximum Gallons	Annual Contract Maximum AF
23-06	City of Coffeyville	12/17/2033	500,000,000	1,534	500,000,000	1,534
99-5	Coffeyville Resources	12/3/2039	608,000,000	1,866	608,000,000	1,866
12-7	Coffeyville Resources	8/9/2051	400,000,000	1,228	400,000,000	1,228
22-01	City of Independence	8/17/2062	60,000,000	184	60,000,000	184
23-08	City of Independence	10/18/2028	200,000,000	614		614
			1,568,000,000	5,426	1,568,000,000	5,426

Table 3: Pending Applications

Applicant Name	Application Expiration Date	Requested Quantity Gallons	Requested Quantity AF
There are no pending applications on file			

Table 4: Past Surplus Contracts

Contract Number	Customer Name	Contract End Date	Annual Contract Maximum Gallons	Annual Contract Maximum AF

Table 5: Surplus Yield

mgd	AF/yr	
13.3	14,923	Current Yield
4.8	5,426	Marketing Contracts
0.0	0	WAD Storage Yield
0.0	0	Future Use Yield
8.5	9,496	Surplus Yield
1.33	1,492	Surplus Yield Available

Lake Level Management Consideration

No Lake Level Management Plan was prepared for Elk City for Water Year 2026.

Hillsdale Lake

Table 1: Conservation Storage Break Out

Conservation Pool Elevation (ft msl)	850 - 917	Flood Pool Elevation (ft msl)		917 - 931
	Break Out of Conservation Storage	Current Yield (mgd)		Current Storage (acre feet)
Water Quality	22.06%	0		16,564
Other/Local	0.00%	0		0
Water Supply	77.94%	15.3		58,524
Future Use	53.26%	10.5		39,992
In Service	24.68%	4.9		18,532
Water Marketing	24.68%	4.9		18,532
Assurance District	0.00%	0.0		0
Reserve Capacity	0.00%	0.0		0

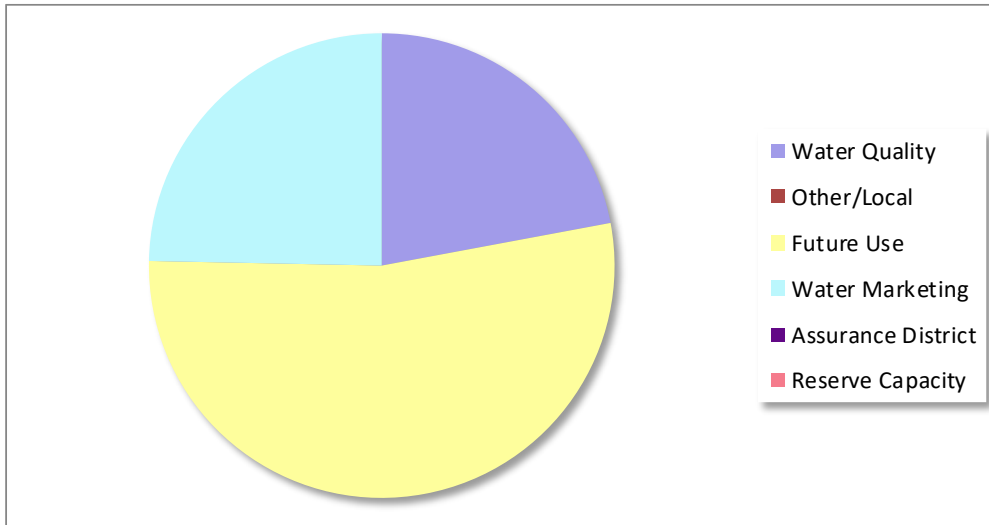

Table 2: Contracted Quantities

Contract Number	Customer Name	Contract End Date	2026 Maximum Gallons	2026 Maximum AF	Annual Contract Maximum Gallons	Annual Contract Maximum AF
13-1	Hillsdale Area Water Cooperative	12/31/2052	5,308,560,000	16,291	5,308,560,000	16,291
			5,308,560,000	16,291	5,308,560,000	16,291

Table 3: Pending Applications

Applicant Name	Application Expiration Date	Requested Quantity Gallons	Requested Quantity AF
Hillsdale Area Water Cooperative		239,440,000	735

Table 4: Past Surplus Contracts

Contract Number	Customer Name	Contract End Date	Annual Contract Maximum Gallons	Annual Contract Maximum AF
There were no surplus contracts in the past two years				

Table 5: Surplus Yield

mgd	AF/yr	
15.3	17,173	Current Yield
14.5	16,291	Marketing Contracts
0.0	0	WAD Storage Yield
10.5	11,735	Future Use Yield
0.0	0	Surplus Yield
0.00	0	Surplus Yield Available

Lake Level Management Consideration

According to the Lake Level Management Plan, pool level may be lowered in January (or prior to freezing).

Hillsdale Lake
 Conservation Pool = 917.0 Flood Pool (FP) = 931.0 5% into FP = 917.8

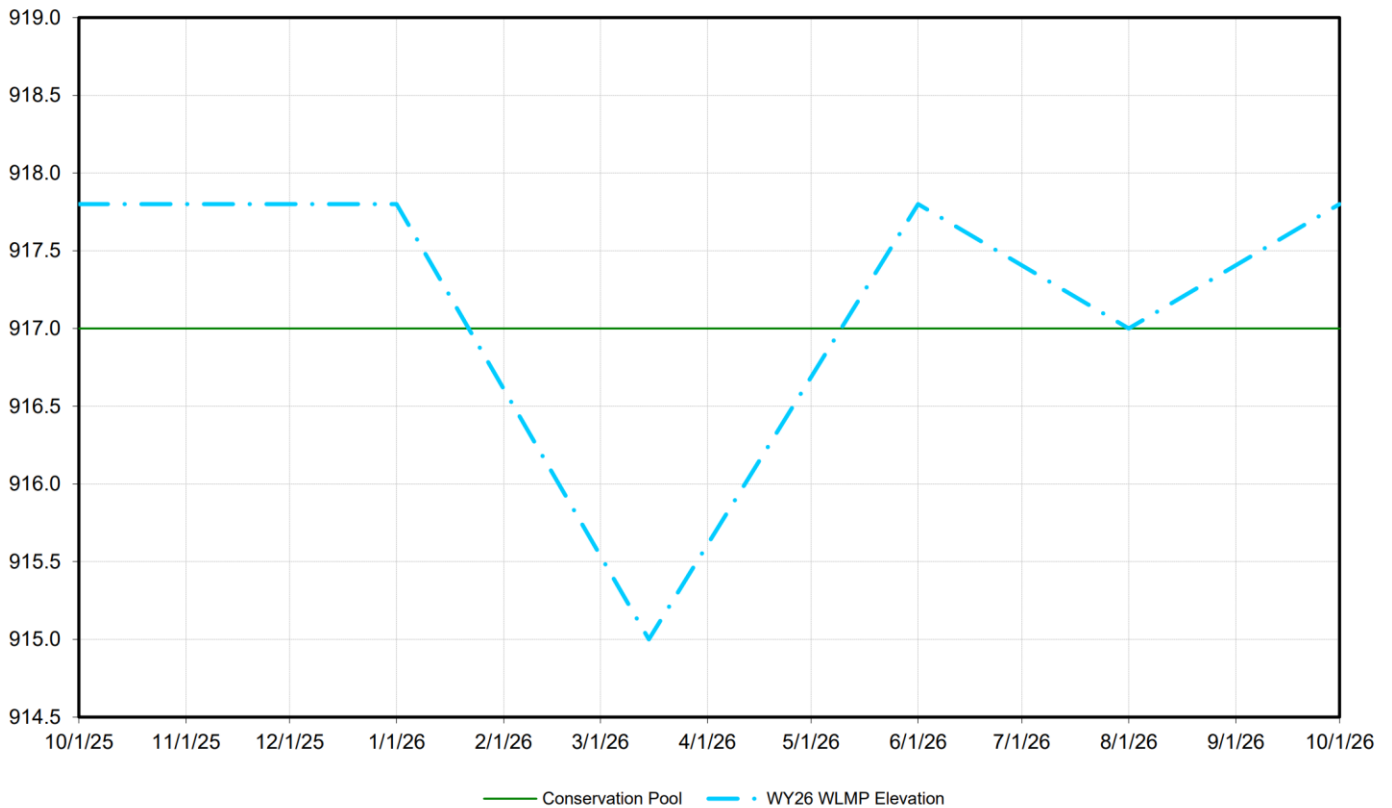

John Redmond Reservoir

Table 1: Conservation Storage Break Out

Conservation Pool Elevation (ft msl)	1020 - 1041	Flood Pool Elevation (ft msl)	1041 - 1068
	Break Out of Conservation Storage	Current Yield (mgd)	Current Storage (acre feet)
Water Quality	23.82%	0	13,465
Other/Local	0.00%	0	0
Water Supply	76.18%	30.0	43,063
Future Use	0.00%	0.0	0
In Service	76.18%	30.0	43,063
Water Marketing	69.06%	27.2	39,038
Assurance District	7.12%	2.8	4,025
Reserve Capacity	0.00%	0.0	0

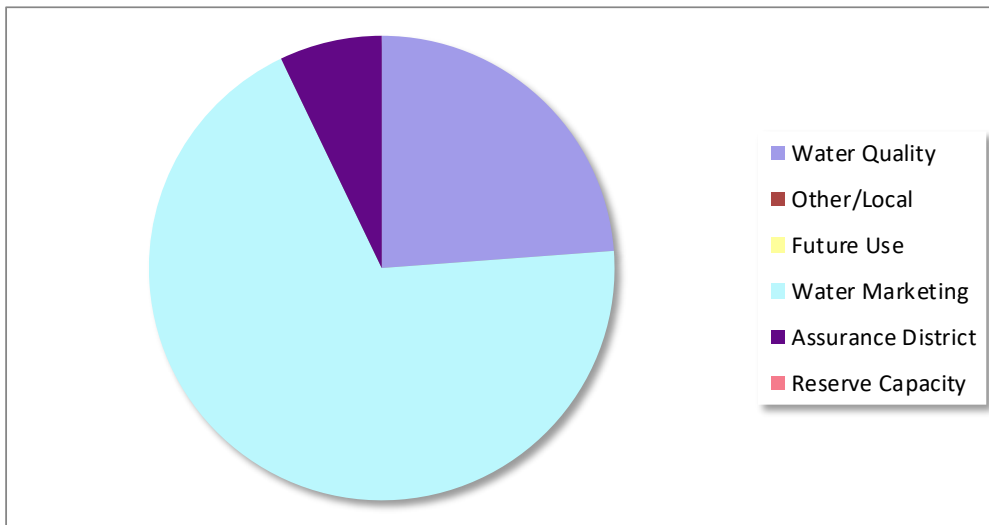

Table 2: Contracted Quantities

Contract Number	Customer Name	Contract End Date	2026 Maximum Gallons	2026 Maximum AF	Annual Contract Maximum Gallons	Annual Contract Maximum AF
17-2	Wolf Creek Nuclear Generating Station (KG&E, KCP&L, KEPC)	12/31/2045	9,368,000,000	28,749	9,368,000,000	28,749
			9,368,000,000	28,749	9,368,000,000	28,749

Table 3: Pending Applications

Applicant Name	Application Expiration Date	Requested Quantity Gallons	Requested Quantity AF
There are no pending applications on file			

Table 4: Past Surplus Contracts

Contract Number	Customer Name	Contract End Date	Annual Contract Maximum Gallons	Annual Contract Maximum AF
There were no surplus contracts in the past two years				

Table 5: Surplus Yield

mgd	AF/yr	
30.0	33,634	Current Yield
25.6	28,749	Marketing Contracts
2.8	3,144	WAD Storage Yield
0.0	0	Future Use Yield
1.6	1,741	Surplus Yield
0.00	0	*Surplus Yield Available

**The simple yield calculations of the spreadsheet model do result in a small amount of surplus, however, the OASIS system model, incorporating a more dynamic operation and demand pattern, indicates that additional contract obligations should not be made available.*

Lake Level Management Consideration

No Lake Level Management Plan was prepared for John Redmond for Water Year 2026.

Kanopolis Lake

Table 1: Conservation Storage Break Out

Conservation Pool Elevation (ft msl)	1431 - 1463	Flood Pool Elevation (ft msl)	1463 - 1508
	Break Out of Conservation Storage	Current Yield (mgd)	Current Storage (acre feet)
Water Quality	53.40%	0	23,360
Other/Local	0.00%	0	0
Water Supply	46.60%	8.0	20,385
Future Use	0.00%	0.0	0
In Service	46.60%	8.0	20,385
Water Marketing	22.37%	3.9	9,786
Access District	24.23%	4.2	10,599
Reserve Capacity	0.00%	0.0	0

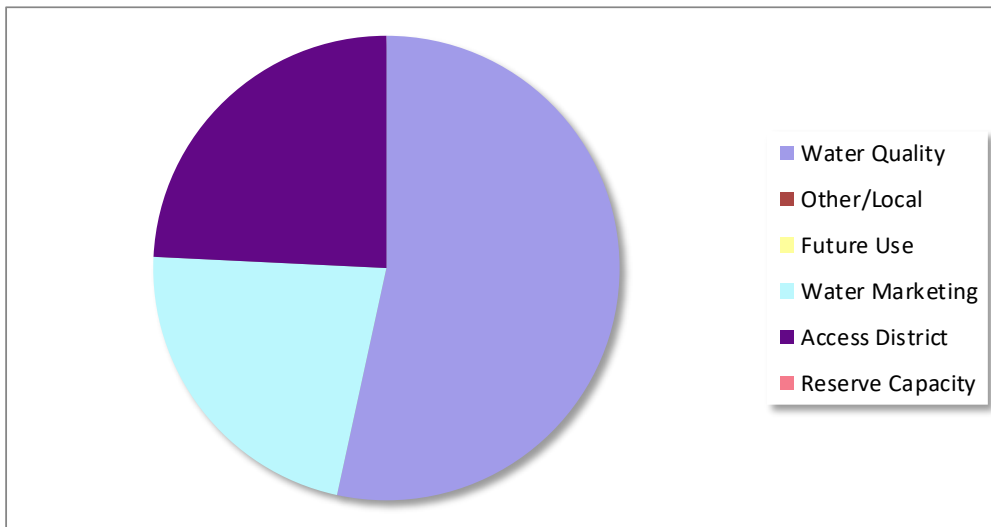

Table 2: Contracted Quantities

Contract Number	Customer Name	Contract End Date	2026 Maximum Gallons	2026 Maximum AF	Annual Contract Maximum Gallons	Annual Contract Maximum AF
01-2	Post Rock Rural Water District	7/12/2041	400,000,000	1,228	400,000,000	1,228
			400,000,000	1,228	400,000,000	1,228

Table 3: Pending Applications

Applicant Name	Application Expiration Date	Requested Quantity Gallons	Requested Quantity AF
There are no pending applications on file			

Table 4: Past Surplus Contracts

Contract Number	Customer Name	Contract End Date	Annual Contract Maximum Gallons	Annual Contract Maximum AF
There were no surplus contracts in the past two years				

Table 5: Surplus Yield

mgd	AF/yr	
8.0	8,993	Current Yield
1.1	1,228	Marketing Contracts
4.2	4,676	AD Storage Yield
0.0	0	Future Use Yield
2.8	3,089	Surplus Yield
0.0	0 *	Surplus Yield Available

*Two feet of storage evacuated to facilitate a maintenance and construction project within the outlet works, which will reduce CY 2026 yield available.

Lake Level Management Consideration

In accordance with the Lake Level Management Plan for Kanopolis, conservation storage will be evacuated during the 2026 Water Year. The reservoir drawdown is to facilitate a construction and maintenance project within the downstream outlet corridor. Reservoir releases will be limited during the duration of this project.

Kanopolis Lake

Conservation Pool = 1463.0 Flood Pool (FP) = 1508.0 5% into FP = 1468.7

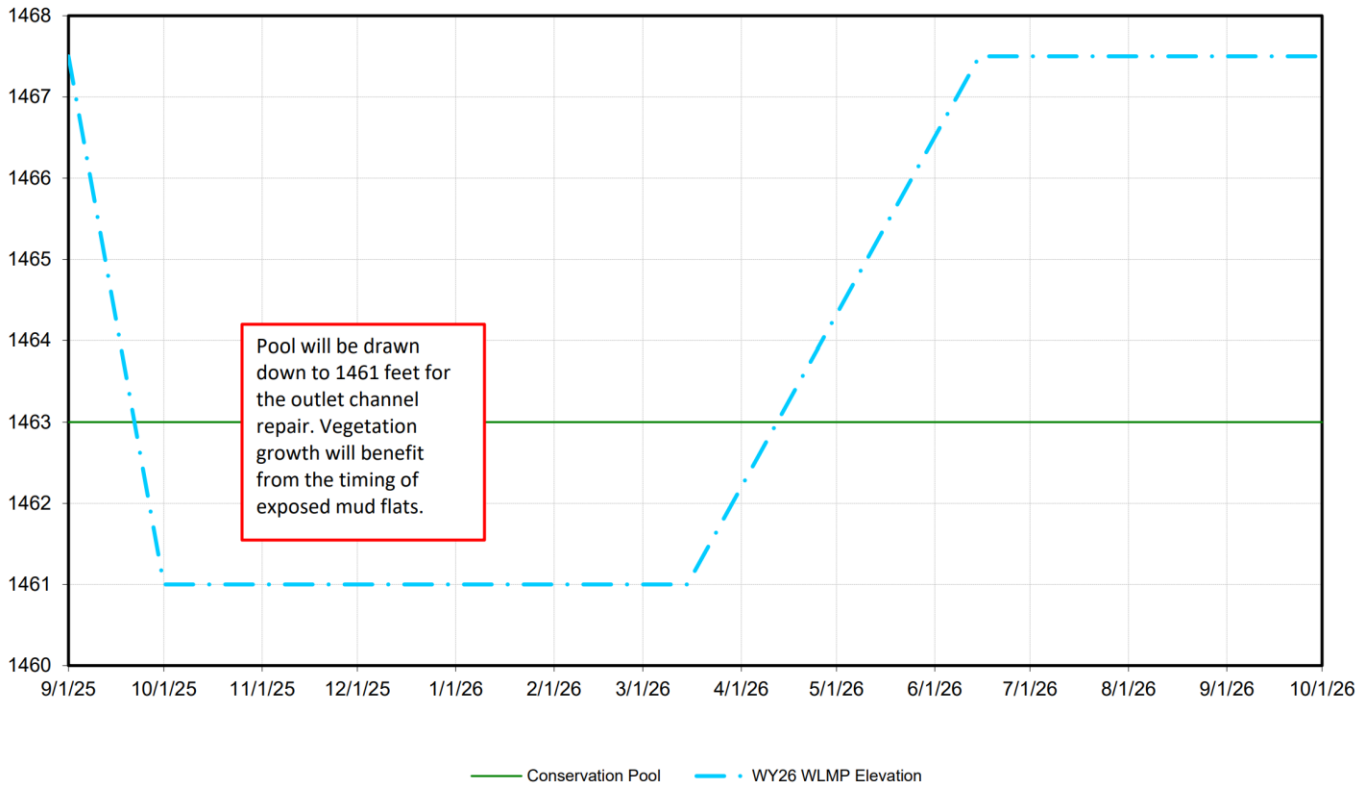

Marion Reservoir

Table 1: Conservation Storage Break Out

Conservation Pool Elevation (ft msl)	1320 - 1350.5	Flood Pool Elevation (ft msl)	1350.5 - 1358.5
	Break Out of Conservation Storage	Current Yield (mgd)	Current Storage (acre feet)
Water Quality	35.88%	0	27,474
Other/Local	0.00%	0	0
Water Supply	64.12%	4.0	49,097
Future Use	0.00%	0.0	0
In Service	64.12%	4.0	49,097
Water Marketing	45.77%	2.83	35,046
Assurance District	0.43%	0.03	329
Reserve Capacity	17.92%	1.11	13,721

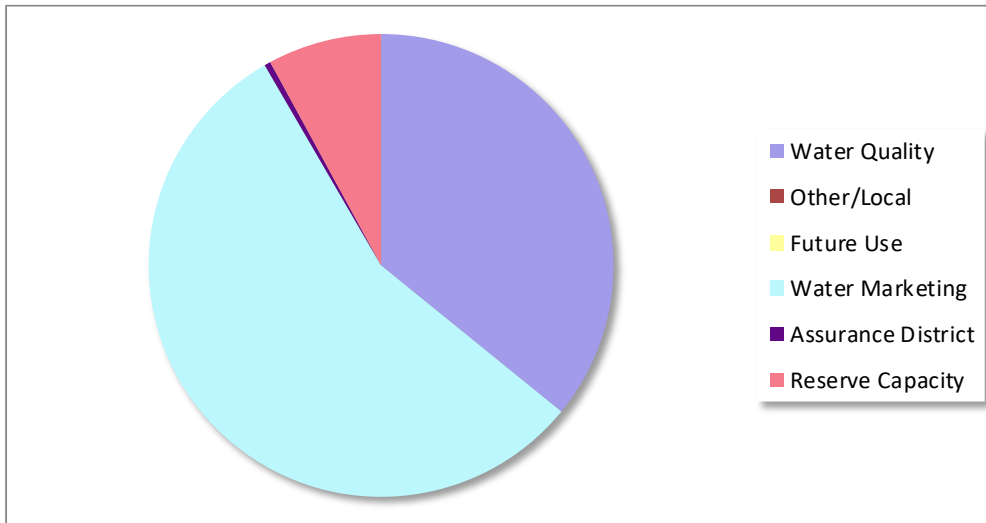

Table 2: Contracted Quantities

Contract Number	Customer Name	Contract End Date	2026 Maximum Gallons	2026 Maximum AF	Annual Contract Maximum Gallons	Annual Contract Maximum AF
23-1	City of Marion	10/3/2063	237,500,000	729	237,500,000	729
99-1	City of Peabody	4/9/2039	60,000,000	184	60,000,000	184
21-3	City of Hillsboro	12/22/2061	300,000,000	921	300,000,000	921
17-2	Wolf Creek Nuclear Generating Station	12/31/2045				
			597,500,000	1,834	597,500,000	1,834

Table 3: Pending Applications

Applicant Name	Application Expiration Date	Requested Quantity Gallons	Requested Quantity AF
There are no pending applications on file			

Table 4: Past Surplus Contracts

Contract Number	Customer Name	Contract End Date	Annual Contract Maximum Gallons	Annual Contract Maximum AF

Table 5: Surplus Yield

mgd	AF/yr	
4.0	4,445	Current Yield
1.64	1,834	Marketing Contracts
0.03	30	WAD Storage Yield
0.0	0	Future Use Yield
2.30	2,581	Surplus Yield
0.40	444	Surplus Yield Available

Lake Level Management Consideration

No Lake Level Management Plan was prepared for Marion for Water Year 2026.

Melvern Lake

Table 1: Conservation Storage Break Out

Conservation Pool Elevation (ft msl)	975 - 1036	Flood Pool Elevation (ft msl)	1036 - 1057
	Break Out of Conservation Storage	Current Yield (mgd)	Current Storage (acre feet)
Water Quality	27.59%	0	40,454
Other/Local	37.93%	0	55,615
Water Supply	34.48%	8.6	50,556
Future Use	0.00%	0.0	0
In Service	34.48%	8.6	50,556
Water Marketing	9.90%	2.5	14,516
Assurance District	7.17%	1.8	10,513
Reserve Capacity	17.41%	4.3	25,527

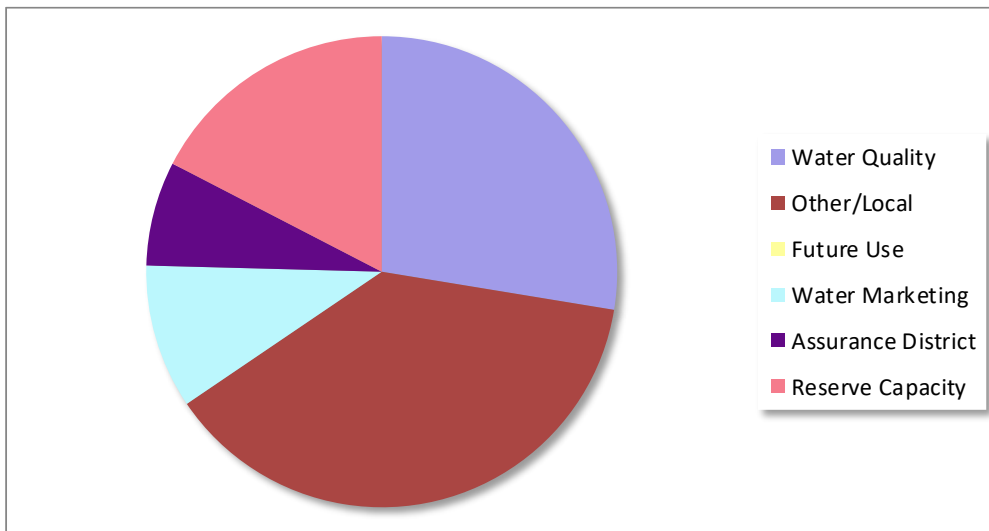

Table 2: Contracted Quantities

Contract Number	Customer Name	Contract End Date	2026 Maximum Gallons	2026 Maximum AF	Annual Contract Maximum Gallons	Annual Contract Maximum AF
93-3	City of Osage City	4/22/2033	100,000,000	307	100,000,000	307
93-2	City of Burlingame	7/15/2033	65,000,000	199	65,000,000	199
93-1	Public Wholesale Water Supply District No. 12	1/1/2035	450,000,000	1,381	547,430,000	1,680
05-6	City of Harveyville	8/11/2045	25,000,000	77	25,000,000	77
			640,000,000	1,964	737,430,000	2,263

Table 3: Pending Applications

Applicant Name	Application Expiration Date	Requested Quantity Gallons	Requested Quantity AF
Public Wholesale Water Supply District No. 12	7/31/2034	714,040,000	2,191

Table 4: Past Surplus Contracts

Contract Number	Customer Name	Contract End Date	Annual Contract Maximum Gallons	Annual Contract Maximum AF
There were no surplus contracts in the past two years				

Table 5: Surplus Yield

mgd	AF/yr	
8.6	9,590	Current Yield
1.8	1,964	Marketing Contracts
1.8	1,994	WAD Storage Yield
0.0	0	Future Use Yield
5.0	5,632	Surplus Yield
0.86	959	Surplus Yield Available

Lake Level Management Consideration

According to the Lake Level Management Plan, pool level may be lowered in December (or prior to freezing).

Melvern Lake

Conservation Pool = 1036.0 Flood Pool (FP) = 1057.0 5% into FP = 1037.5

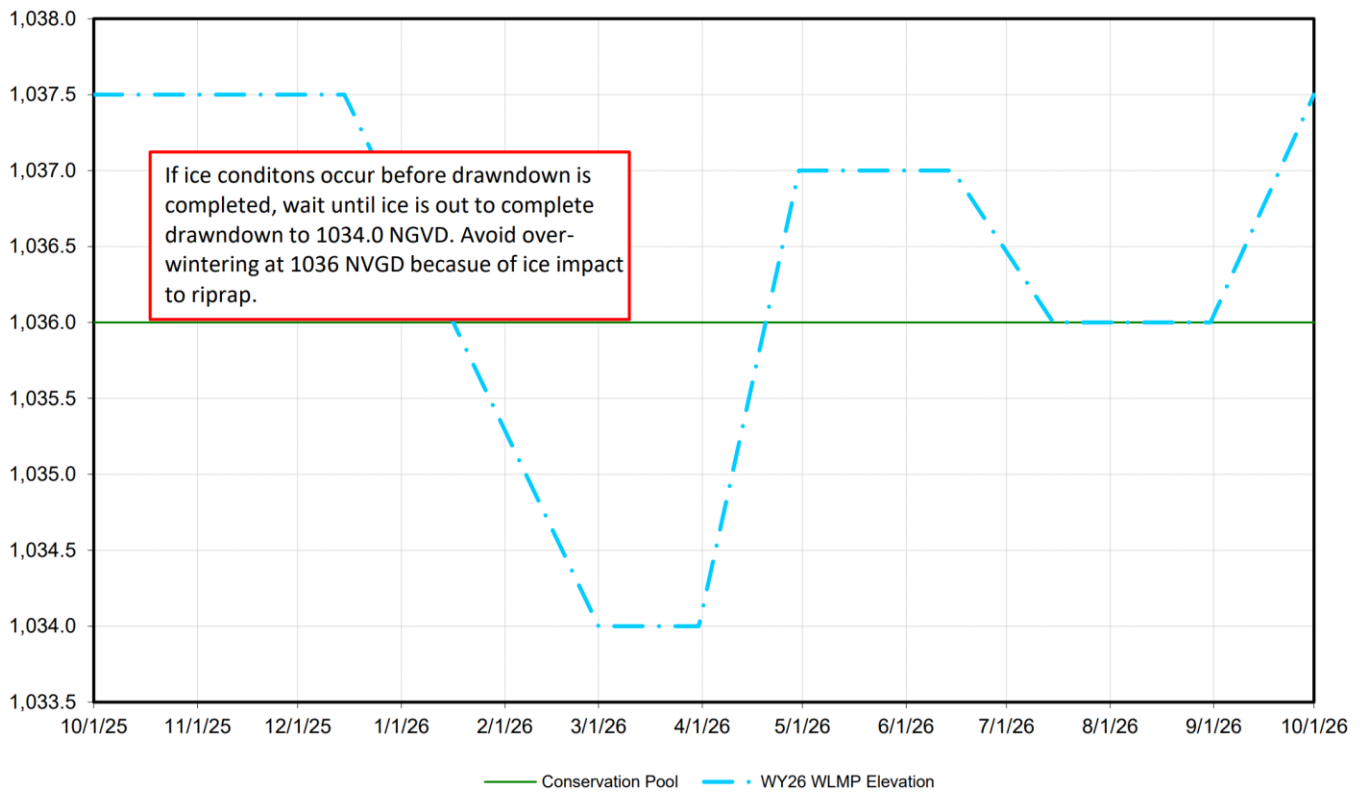

Milford Lake

Table 1: Conservation Storage Break Out

Conservation Pool Elevation (ft msl)	1080 - 1144.4	Flood Pool Elevation (ft msl)	1144.4 - 1176.2
	Break Out of Conservation Storage	Current Yield (mgd)	Current Storage (acre feet)
Water Quality	0.00%	0	0
Other/Local	0.00%	0	0
Water Supply	100.00%	106	357,079
Future Use	66.12%	70	236,100
In Service	33.88%	36	120,978
Water Marketing	0.00%	0	0
Assurance District	18.33%	19	65,452
Reserve Capacity	15.55%	17	55,526

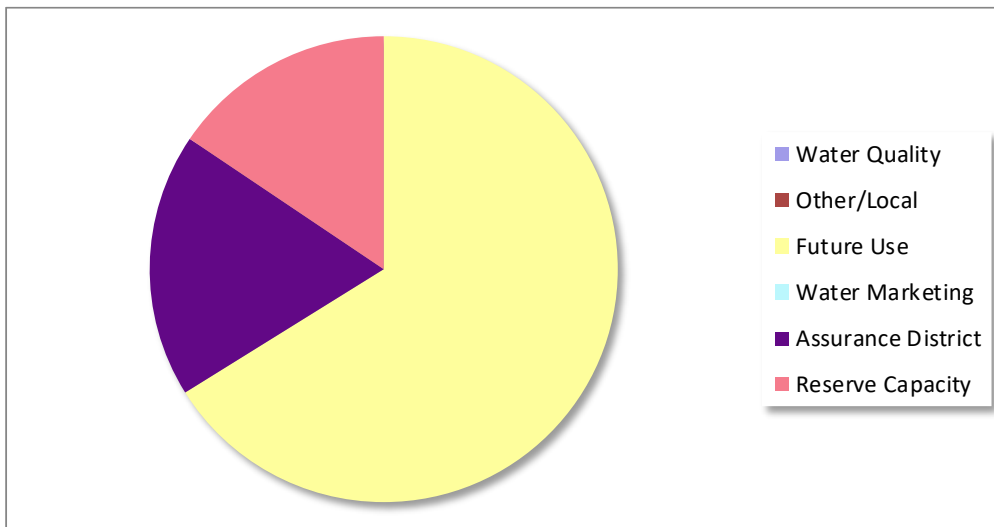

Table 2: Contracted Quantities

Contract Number	Customer Name	Contract End Date	2026 Maximum Gallons	2026 Maximum AF	Annual Contract Maximum Gallons	Annual Contract Maximum AF
There are no contracted quantities						

Table 3: Pending Applications

Applicant Name	Application Expiration Date	Requested Quantity Gallons	Requested Quantity AF
There are no pending applications on file			

Table 4: Past Surplus Contracts

Contract Number	Customer Name	Contract End Date	Annual Contract Maximum Gallons	Annual Contract Maximum AF
There were no surplus contracts in the past two years				

Table 5: Surplus Yield

mgd	AF/yr	
106	118,985	Current Yield
0	0	Marketing Contracts
19	21,810	WAD Storage Yield
70	78,673	Future Use Yield
16.5	18,502	Surplus Yield
10.62	11,899	Surplus Yield Available

Lake Level Management Consideration

In accordance with the Lake Level Management Plan for Milford, pool level will be lowered. The drawdown will be made in an attempt to mitigate the impact of the harmful algal blooms in the lake. The quantity of water in the future use pool is sufficient for the evacuation of storage associated with the change in elevation.

Milford Lake
Conservation Pool = 1144.4 Flood Pool (FP) = 1176.2 5% into FP = 1146.6

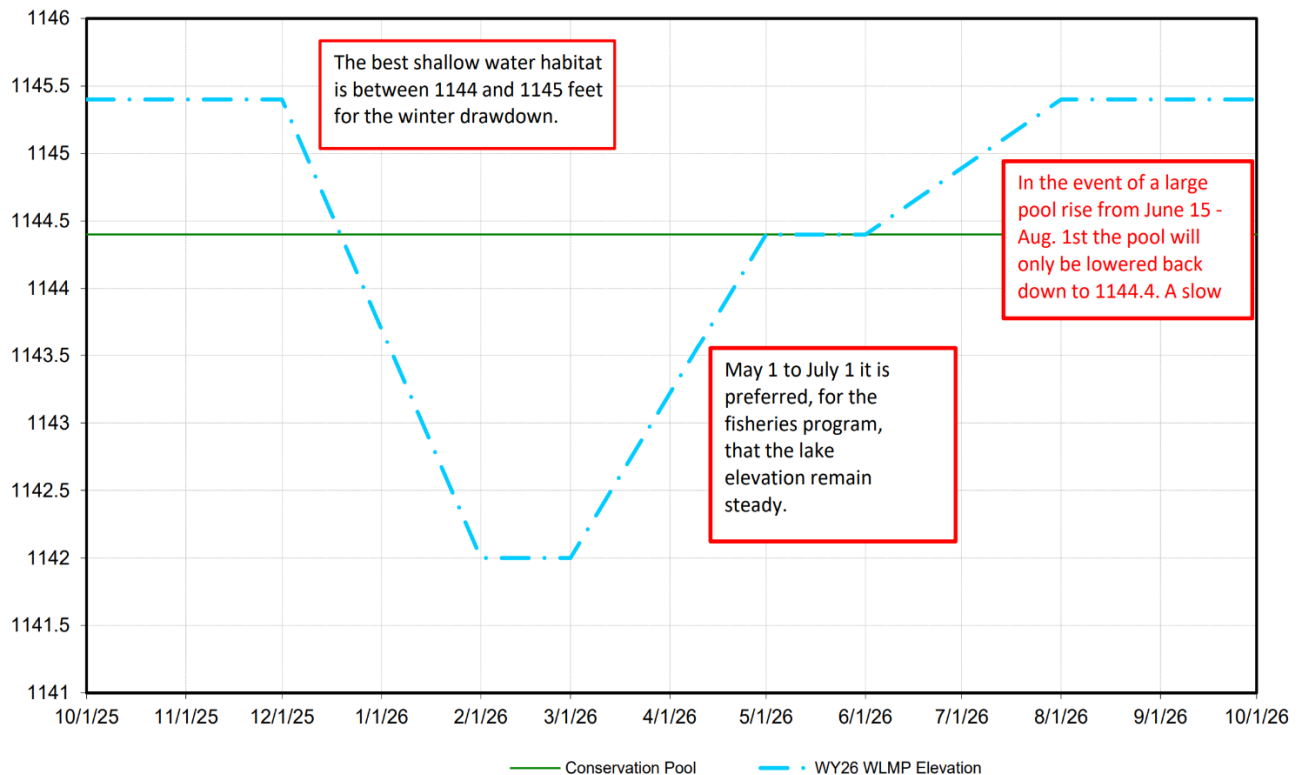

Perry Lake

Table 1: Conservation Storage Break Out

Conservation Pool Elevation (ft msl)	850 - 891.5	Flood Pool Elevation (ft msl)	891.5 - 920.6
	Break Out of Conservation Storage	Current Yield (mgd)	Current Storage (acre feet)
Water Quality	0.00%	0	0
Other/Local	0.00%	0	0
Water Supply	100.00%	76.4	186,958
Future Use	83.33%	63.7	155,792
In Service	16.67%	12.7	31,166
Water Marketing	0.00%	0.0	0
Assurance District	16.67%	12.7	31,166
Reserve Capacity	0.00%	0.0	0

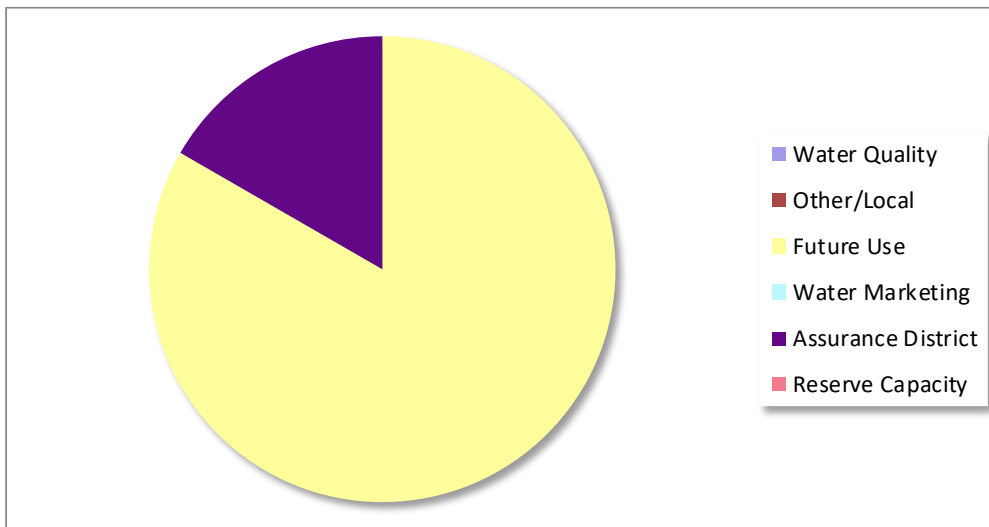

Table 2: Contracted Quantities

Contract Number	Customer Name	Contract End Date	2026 Maximum Gallons	2026 Maximum AF	Annual Contract Maximum Gallons	Annual Contract Maximum AF
There are no contracted quantities						

Table 3: Pending Applications

Applicant Name	Application Expiration Date	Requested Quantity Gallons	Requested Quantity AF
There are no pending applications on file			

Table 4: Past Surplus Contracts

Contract Number	Customer Name	Contract End Date	Annual Contract Maximum Gallons	Annual Contract Maximum AF
There were no surplus contracts in the past two years				

Table 5: Surplus Yield

mgd	AF/yr	
76.4	85,650	Current Yield
0.0	0	Marketing Contracts
12.7	14,278	WAD Storage Yield
63.7	71,372	Future Use Yield
0.0	0	Surplus Yield
0.00	0	Surplus Yield Available

Lake Level Management Consideration

In accordance with the Lake Level Management Plan for Perry, pool level will be lowered in February. The quantity of water in the future use pool is sufficient for the evacuation of storage associated with the change in elevation.

Perry Lake
 Conservation Pool = 891.5 Flood Pool (FP) = 920.6 5% into FP = 893.9

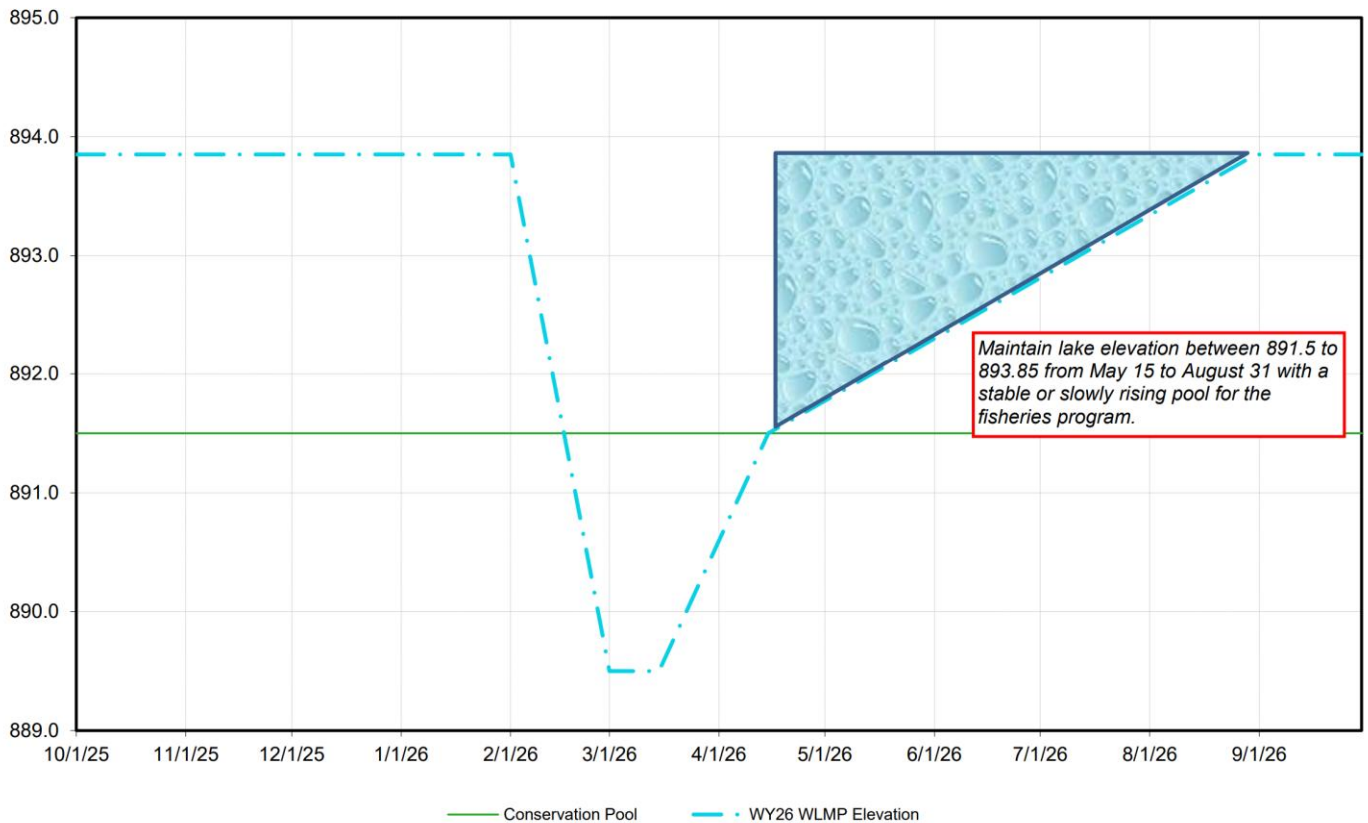

Pomona Lake

Table 1: Conservation Storage Break Out

Conservation Pool Elevation (ft msl)	945 - 974	Flood Pool Elevation (ft msl)	974 - 1003
	Break Out of Conservation Storage	Current Yield (mgd)	Current Storage (acre feet)
Water Quality	25.24%	0	12,502
Other/Local	0.89%	0	442
Water Supply	73.86%	7.6	36,578
Future Use	0.00%	0.0	0
In Service	73.86%	7.6	36,578
Water Marketing	1.52%	0.2	753
Assurance District	23.63%	2.4	11,703
Reserve Capacity	48.71%	5.0	24,123

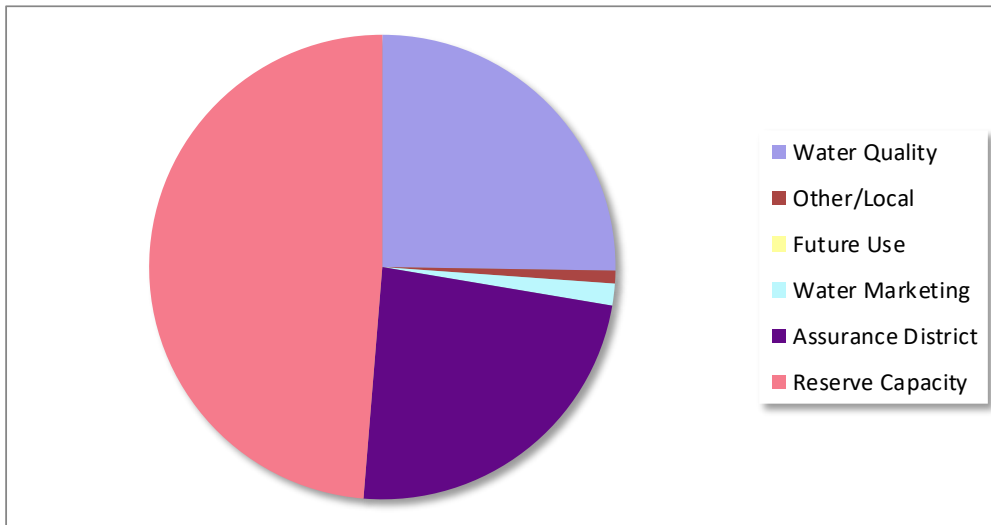

Table 2: Contracted Quantities

Contract Number	Customer Name	Contract End Date	2026 Maximum Gallons	2026 Maximum AF	Annual Contract Maximum Gallons	Annual Contract Maximum AF
05-5	Osage County Rural Water District No. 3	7/10/2048	55,600,000	171	55,600,000	171
			55,600,000	171	55,600,000	171

Table 3: Pending Applications

Applicant Name	Application Expiration Date	Requested Quantity Gallons	Requested Quantity AF
There are no pending applications on file			

Table 4: Past Surplus Contracts

Contract Number	Customer Name	Contract End Date	Annual Contract Maximum Gallons	Annual Contract Maximum AF
There were no surplus contracts in the past two years				

Table 5: Surplus Yield

mgd	AF/yr	
7.6	8,488	Current Yield
0.2	171	Marketing Contracts
2.4	2,716	WAD Storage Yield
0.0	0	Future Use Yield
5.0	5,602	Surplus Yield
0.76	849	Surplus Yield Available

Lake Level Management Consideration

In accordance with the Lake Level Management Plan for Pomona, pool level will be lowered in December.

Pomona Lake
 Conservation Pool = 974.0 Flood Pool (FP) = 1003.0 5% into FP = 976.3

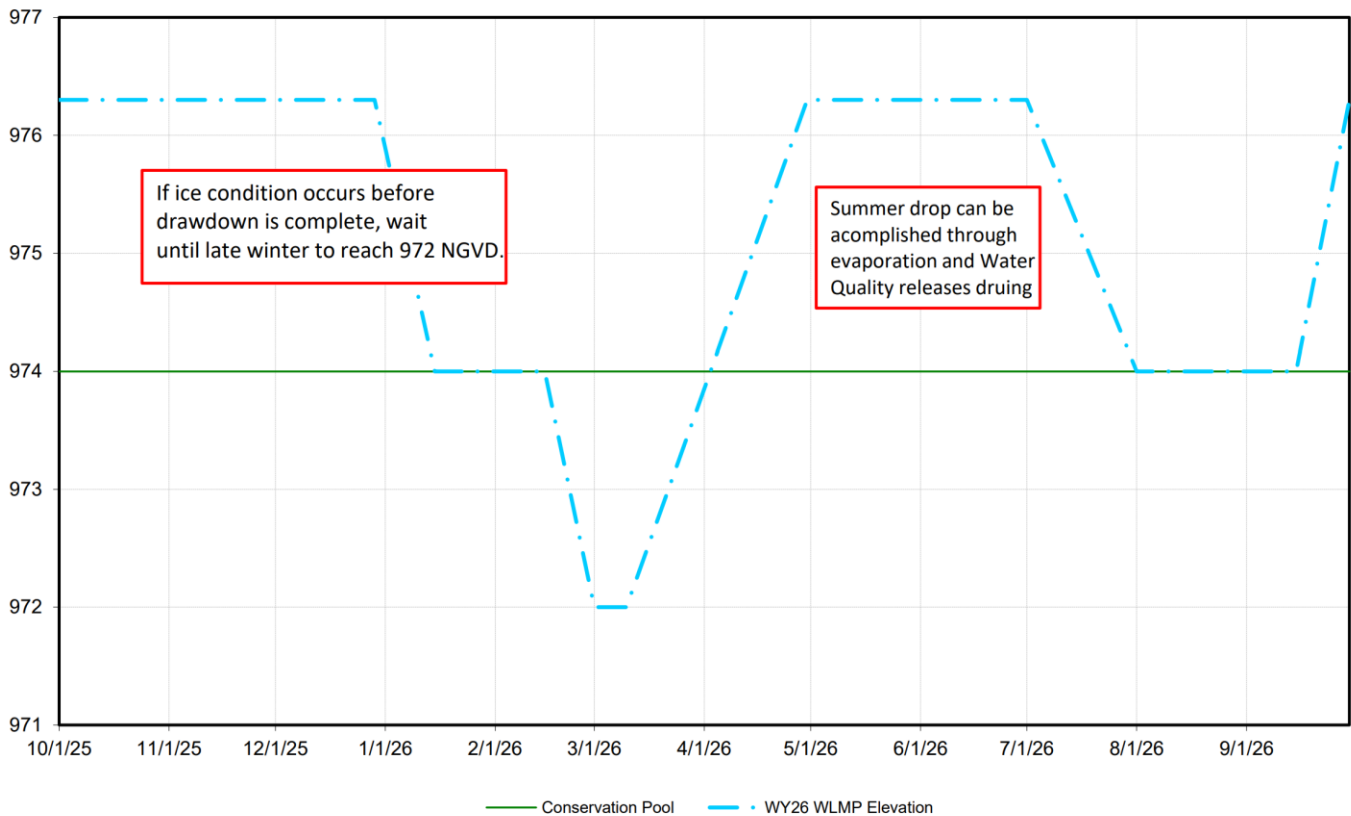

Toronto Lake

Table 1: Conservation Storage Break Out

Conservation/Inactive Pool Elev. (ft msl)	856 - 901.5	Flood Pool Elevation (ft msl)		901.5 - 931
	Break Out of Conservation Storage	Current Yield (mgd)	Current Storage (acre feet)	
Water Quality/Supply	57.51%	2.5	7,323	
Inactive (Below 896.0)	40.26%	1.8	5,127	
Water Supply	2.23%	0.1	284	
Future Use	0.00%	0.0	0	
In Service	2.23%	0.1	284	
Water Marketing	0.00%	0.0	0	
Assurance District	0.00%	0.0	0	
Reserve Capacity	2.23%	0.1	284	

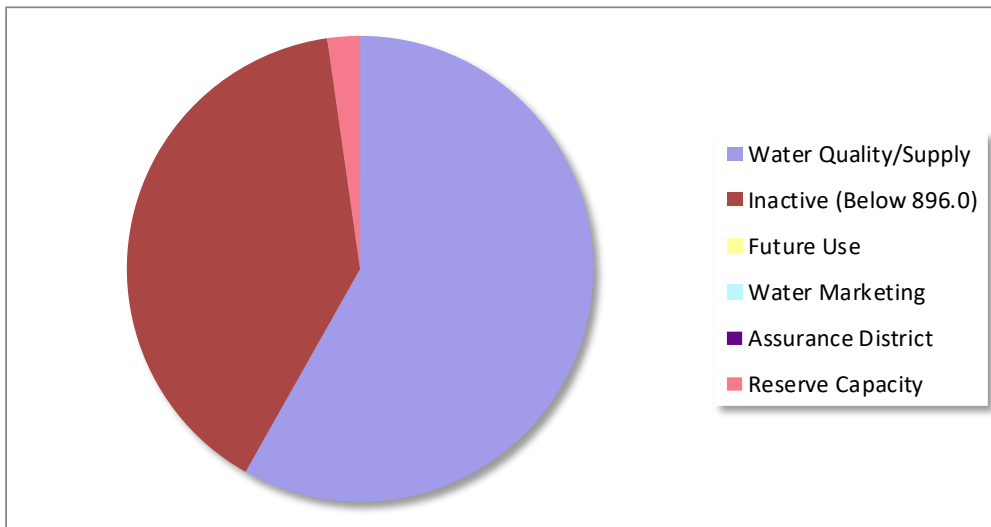

Table 2: Contracted Quantities

Contract Number	Customer Name	Contract End Date	2026 Maximum Gallons	2026 Maximum AF	Annual Contract Maximum Gallons	Annual Contract Maximum AF
There are no contracted quantities						

Table 3: Pending Applications

Applicant Name	Application Expiration Date	Requested Quantity Gallons	Requested Quantity AF
There are no pending applications on file			

Table 4: Past Surplus Contracts

Contract Number	Customer Name	Contract End Date	Annual Contract Maximum Gallons	Annual Contract Maximum AF
There were no surplus contracts in the past two years				

Table 5: Surplus Yield

mgd	AF/yr	
4.4	4,917	Current Yield
0.0	0	Marketing Contracts
0.0	0	WAD Storage Yield
0.0	0	Future Use Yield
0.1	110	Surplus Yield
0.10	110	Surplus Yield Available

Lake Level Management Consideration

No Lake Level Management Plan was prepared for Toronto for Water Year 2026.

Tuttle Creek Lake

Table 1: Conservation Storage Break Out

Conservation Pool Elevation (ft msl)	1020 - 1075	Flood Pool Elevation (ft msl)	1075 - 1136
	Break Out of Conservation Storage	Current Yield (mgd)	Current Storage (acre feet)
Water Quality	59.02%	0	125,728
Other/Local	0.00%	0	0
Water Supply	40.98%	160.6	87,298
Future Use	0.00%	0.0	0
In Service	40.98%	160.6	87,298
Water Marketing	0.00%	0.0	0
Assurance District	33.89%	132.9	72,195
Reserve Capacity	7.09%	27.8	15,104

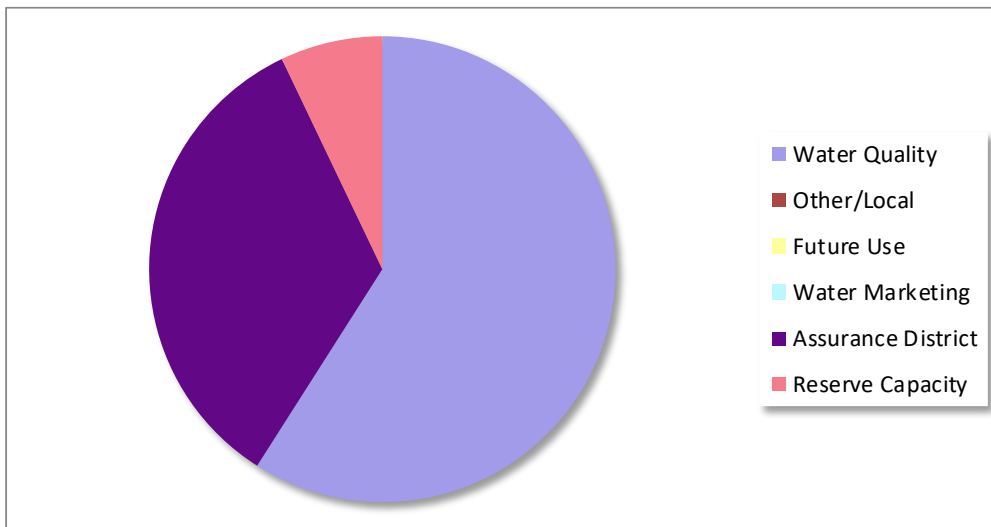

Table 2: Contracted Quantities

Contract Number	Customer Name	Contract End Date	2026 Maximum Gallons	2026 Maximum AF	Annual Contract Maximum Gallons	Annual Contract Maximum AF
There are no contracted quantities						

Table 3: Pending Applications

Applicant Name	Application Expiration Date	Requested Quantity Gallons	Requested Quantity AF
There are no pending applications on file			

Table 4: Past Surplus Contracts

Contract Number	Customer Name	Contract End Date	Annual Contract Maximum Gallons	Annual Contract Maximum AF
There were no surplus contracts in the past two years				

Table 5: Surplus Yield

mgd	AF/yr	
161	180,063	Current Yield
0	0	Marketing Contracts
133	148,910	WAD Storage Yield
0	0	Future Use Yield
28	31,153	Surplus Yield
16.1	18,006	Surplus Yield Available

Lake Level Management Consideration

In accordance with the Lake Level Management Plan for Tuttle Creek, pool level will be lowered in December.

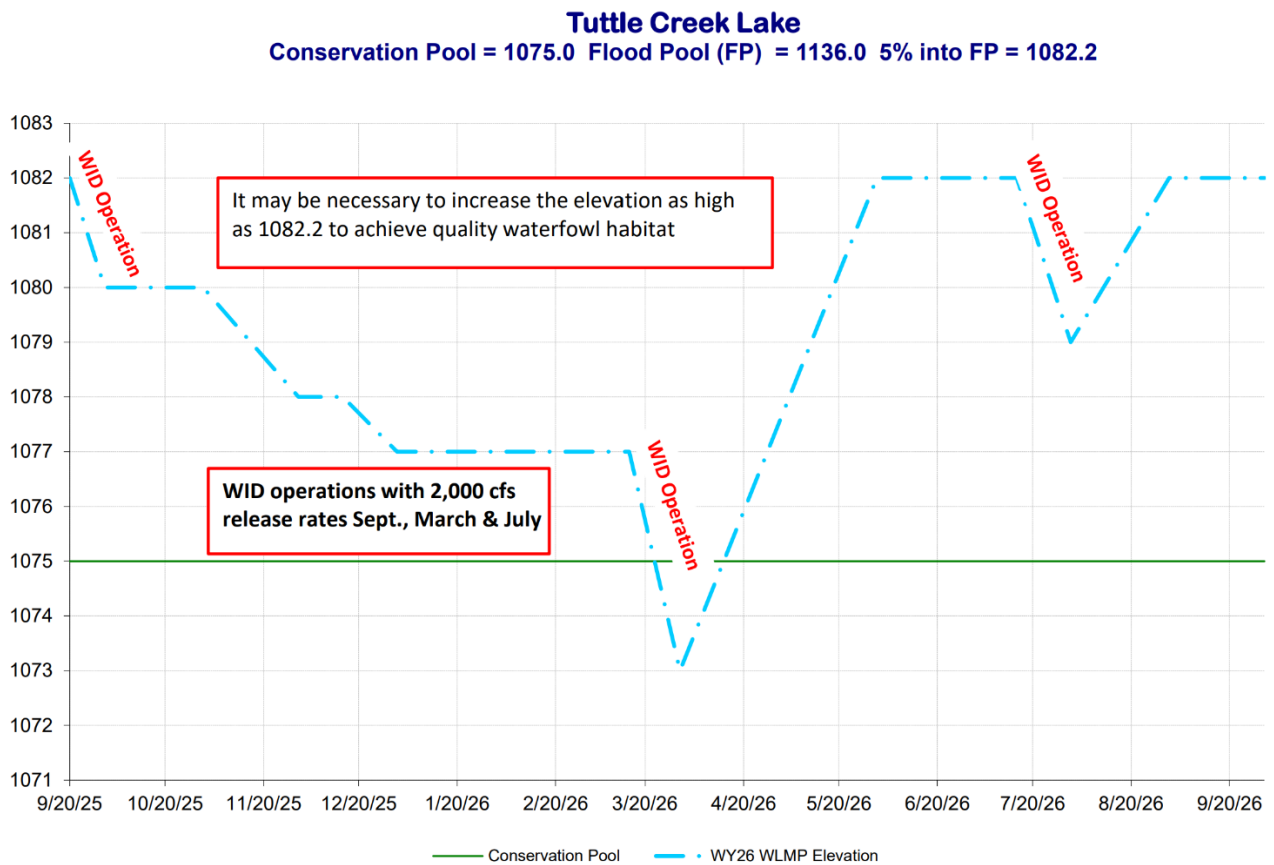

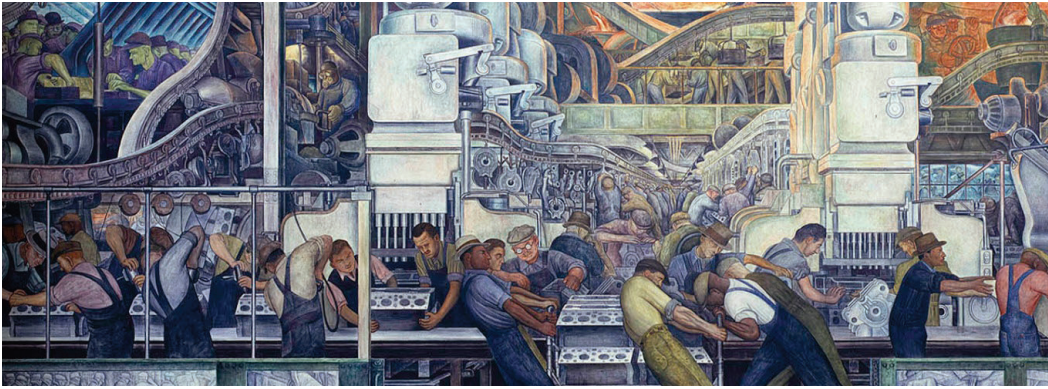

WHAT HAPPENS WHEN DATA CENTERS COME TO TOWN?

Terry Nguyen

BA Public Policy

Ben Green

Assistant Professor, School of Information and
Gerald R. Ford School of Public Policy

Partner: Michigan Environmental Justice
Coalition

Introduction

The rapid growth of data centers, with their enormous energy and water demands, necessitates targeted policy interventions to mitigate environmental impacts and protect local communities. To address these issues, states with existing data center tax breaks should adopt sustainable growth policies for data centers, mandating energy audits, strict performance standards, and renewable energy integration, while also requiring transparency in energy usage reporting. “Renewable energy additionality” clauses should ensure data centers contribute to new renewable capacity rather than relying on existing resources. If these measures prove insufficient, states should consider repealing tax breaks to slow unsustainable data center growth. States without tax breaks should avoid such incentives altogether while simultaneously implementing mandatory reporting requirements to hold data centers accountable for their environmental impact. Broader measures should include protecting local tax revenues for schools, regulating utility rate hikes to prevent cost-shifting to consumers, and aligning data center energy demands with state climate goals to avoid prolonging reliance on fossil fuels.

Key Findings

Increased Utility Rates: Data centers increase local electric utility rates by driving up overall energy demand, which can strain grid capacity and force utilities to invest in costly infrastructure upgrades. These costs are passed on to residents through higher rates. Data centers have also secured long-term power agreements, which reduce the available supply and push prices up for other consumers.

High Resource Consumption: A single data center can consume up to 2 megawatt hours of power—equivalent to the power used by 2,000 homes—and millions of gallons of water annually for cooling, straining local resources and infrastructure.

Ineffective Tax Incentives: Tax breaks for data centers do not deliver the promised economic benefits, such as high-paying jobs, and they reduce local tax revenues, while shifting financial burdens onto communities and schools.

Climate and Energy Challenges: Data centers' massive energy demands are prolonging the operation of fossil fuel plants and undermining state renewable energy goals, as seen in states like Michigan, Virginia, and Nebraska.

Resource Efficiency Trade-Off: While advanced cooling methods like liquid immersion and direct-to-chip cooling offer energy efficiency improvements, current technologies force a trade-off between energy and water efficiency, limiting sustainable solutions.

Policy Solutions: To mitigate data centers' environmental impacts and align their growth with sustainability goals, policymakers should adopt model laws like the German Energy Efficiency Act, add requirements for new renewable energy, and enforce transparency through mandatory reporting.

Background: Data Centers and the Environment

What is a data center?

A data center is a specialized facility designed to house and manage an organization's IT infrastructure, including servers, storage systems, networking equipment, and other hardware essential for processing, storing, and distributing vast amounts of data. These facilities serve as the backbone of modern digital services, enabling everything from cloud computing and online transactions to streaming platforms and artificial intelligence (AI) applications. Data center designs incorporate advanced cooling systems, backup power, and in-house cybersecurity measures to ensure efficiency, reliability, and security. As data centers continue to grow in scale and complexity, their energy use and environmental footprint are also expanding.

Why are data centers growing so rapidly?

Data centers are growing rapidly due to the exponential increase in data generation and consumption occurring across industries. The proliferation of cloud computing, internet of things (IoT) devices, artificial intelligence, and big data analytics has created an insatiable demand for storage, processing power, and connectivity. AI has largely driven increases in data center electricity demands as advanced machine learning models require massive computational power for training and inference. One estimate suggests that a prompt on ChatGPT requires 10 times more energy than a traditional Google search.¹ Businesses and consumers rely on seamless and instantaneous access to online services, streaming platforms, and real-time applications, necessitating server infrastructure to support these needs. Additionally, the shift to remote work and hybrid models during the COVID-19

pandemic further accelerated the reliance on cloud-based solutions, pushing data center expansion.



Photo credit: andrei310 - stock.adobe.com

Why do data centers consume water for cooling?

For higher-density data centers, liquid cooling is required to maintain performance requirements. Data centers generate heat primarily due to the electrical energy consumed by servers, storage systems, and networking equipment. When electricity powers these components, a significant portion is converted into heat due to resistance in circuits, semiconductor switching losses, and other inefficiencies. High-performance computing tasks, such as AI training, cloud computing, and large-scale data processing, further intensify heat generation because they demand continuous, heavy workloads.

If this heat is not removed, rising temperatures lead to hardware malfunctions, reduced efficiency, and even permanent damage. Water cooling is often used because it absorbs heat more effectively than air thanks to water's high specific heat capacity (ability to store thermal energy) and thermal conductivity (ability to transfer heat). Twenty-two percent of data

center facilities use water-based cooling systems to absorb and dissipate heat more efficiently than air alone.² Systems like chilled water loops, liquid immersion cooling, or evaporative cooling circulate water to capture and carry away heat and maintain safe operating temperatures while improving energy efficiency compared to air-based methods.

How much water and electricity do data centers use?

Data centers are rapidly growing consumers of electricity and water, driven by their energy-intensive operations and cooling requirements. On average, a single data center can consume up to 2 megawatt hours (MWh) of electricity, which is roughly the equivalent power consumption of a small town. Data centers consumed more than 4% of U.S.



Photo credit: creativenature.nl - stock.adobe.com

electricity in 2023, with estimates suggesting that this consumption could rise to 12% by 2028.³ This massive electricity demand is matched by equally staggering water consumption, as cooling these power-hungry facilities requires vast amounts of water—some individual data centers use hundreds of millions of gallons annually, dwarfing the usage of entire communities the data centers are within. Most facilities use over 10 million gallons (38 million liters) of water per year.⁴ Google's Council Bluffs data

center in Iowa uses around 980 million gallons (3709 million liters) of water per year, which is equivalent to the annual water usage of over 4 million homes.⁵

How does data center cooling work?

Data center cooling relies on six main technologies to manage heat dissipation and maintain optimal performance.

1. Water-cooled systems are water-intensive but energy-efficient.⁶ Chilled water cooling systems use a refrigeration cycle to cool air via chilled coils.
2. Air-cooled systems rely on fans and compressors, consuming more electricity but less water, while Direct Expansion (DX) cooling uses refrigerant to absorb heat directly from the air, making it suitable for smaller data centers.
3. Computer Room Air Handlers (CRAHs) circulate chilled water and air in separate loops, offering efficient temperature and humidity control for larger spaces.
4. Emerging technologies like liquid immersion cooling and direct-to-chip liquid cooling use dielectric fluids to cool components directly, enabling higher power densities and energy savings but requiring specialized equipment.

While these cooling technologies each offer distinct trade-offs between water and energy use, the fundamental challenge remains. Data centers must prioritize either water efficiency or energy efficiency, as existing systems cannot yet optimize both simultaneously. Data center cooling can be optimized for either energy efficiency or water efficiency, but with current cooling technology, achieving both is not possible.



Photo credit: Sepia - stock.adobe.com

The impossibility of an environmentally friendly data center

Data centers cannot fully operate on renewable energy alone. Renewable energy sources like solar and wind are inconsistent and cannot meet the uptime (time during which a machine, especially a computer, is in operation) requirements of data centers. Tier 1 data centers require 99.671% uptime while Tier 4s demand 99.995%. These factors make it impossible for data centers to depend solely on renewables without compromising reliability.

As demand for cloud computing and AI-driven technologies accelerates, data centers are being constructed at a rapid pace, often in areas where existing power infrastructure is insufficient to meet their enormous energy needs. **To ease concerns about environmental impact, data center operators frequently pledge that their facilities will eventually run on clean energy, including next-generation nuclear sources such as small modular reactors (SMRs). However, these SMRs remain largely theoretical, with no commercially viable models yet in operation.**⁷ In the interim, companies claim they will rely on fossil fuels as a temporary “bridge” until greener solutions become available. Yet in practice, this transition is often delayed or abandoned

altogether, resulting in the direct commissioning of new fossil fuel power plants to keep these facilities online.

This gap between promise and reality underscores the fundamental contradiction in labeling data centers as “environmentally friendly.” Battery storage is essential for balancing the intermittent nature of renewable energy generation, but batteries rapidly degrade and are reliant on rare minerals like lithium, nickel, cobalt, manganese, lead, and copper. These minerals are already in short supply due to high demand from the electric vehicle industry. Data centers will also always have an environmental footprint through material resource consumption, water usage, and electricity demands. This makes it unfeasible for them to be completely environmentally friendly.

The Effects on Local Communities

Data centers do not bring in high-paying tech jobs

Data centers do not bring high-paying tech jobs to local communities because they operate as infrastructure projects rather than traditional job-creating businesses. Although the construction of data centers can create many jobs, those are short-lived. Once data centers are built, they require relatively few employees since the facilities primarily house computers and servers.⁸ The jobs that data centers do create locally are typically low-wage, term-limited, non-technical positions such as security, maintenance, and janitorial work. These roles are often filled by contractors rather than full-time employees, meaning they lack union protections, benefits, and job security. As a result, these positions tend to be short-term and do not contribute to sustained economic growth or long-term career opportunities for local residents.

Subsidies intended to encourage job creation result in corporate benefits without local hiring. For example, tax breaks for data centers in Washington State were intended to create jobs in rural areas but primarily benefited large corporations like Microsoft.⁹ Since the inception of the incentives, more than \$300 million in tax revenue has been forgone—money that would otherwise have supported public services such as education, emergency services, and infrastructure. In exchange, the data centers have created few jobs and have required limited staffing for operations. In Quincy, a small town that hosts several large data centers, the local fire department is so underfunded that it struggles to retain personnel and replace outdated equipment—even as Microsoft and other tech giants operate multimillion-dollar facilities nearby. In some cases, the cost to taxpayers for each

job created can exceed \$1 million. Furthermore, the state has little oversight or enforcement mechanisms to ensure that the tech companies deliver on promised benefits. Despite initial legislative goals to boost local employment and economic vitality, the reality is that taxpayers are heavily subsidizing wealthy corporations with minimal transparency or accountability regarding the actual economic impact.



Photo credit: timofeev - stock.adobe.com

Data center tax breaks only benefit corporations

Data center companies locate sites based on electricity prices, land availability, and climate conditions. Although tax breaks are often justified as a way for communities to attract data centers, these policies do not affect data center location decisions. As an executive responsible for Microsoft's North American data centers stated in 2024, "I can't think of a site selection or placement decision that was decided on a set of tax incentives."¹⁰

A new data center in Genesee County, Alabama, could reduce revenues to schools and the local government by \$1.7 million each year.¹¹ Developers are seeking a

minimum \$167 million in tax breaks for the creation of 200 jobs, or \$838,000 per job. These figures far exceed reasonable benchmarks for economic development incentives, making it unlikely that taxpayers will ever see a return on investment. These subsidies would come on top of approximately \$100 million in state funding already spent on preparing the STAMP (Science and Technology Advanced Manufacturing Park) site, making the per-job cost difficult to justify. The high subsidies for STAMP would serve only to boost corporate profits rather than provide meaningful economic benefits to the local community.

Reduced tax revenue for independent school districts

In the case of Switch’s data center in Michigan, the company sought exemptions from property taxes that funded school districts. This move directly reduced the revenue streams for Caledonia Community Schools and Kent Intermediate School District, resulting in a prolonged legal dispute.¹²

In Michigan, tax breaks for data centers exempt them from paying personal property taxes, including on machinery and computers, some of the most valuable assets in their operations.¹³ While they may still pay real property taxes on land and buildings, the overall tax contribution to schools is significantly diminished. This loss of revenue means less funding for educational programs, teacher salaries, and facility improvements, directly impacting the quality of education for students. These tax incentives have shifted the financial burden onto residents and other businesses, who must make up for the lost revenue through higher taxes and reduced public services. Michigan lawmakers initially considered legislation that would have required school districts to reimburse

the company for taxes already paid, further straining school finances.



Photo credit: Monkey Business – stock.adobe.com

Higher energy rates for consumers

When data centers are built, they raise utility rates for nearby communities. **As demand surges, utility companies often pass the costs of infrastructure upgrades and increased energy procurement onto residents and small businesses through higher rates.**¹⁴

Many communities, especially in rural or suburban areas, do not realize the connection until their monthly bills spike. Companies and legislatures also withhold information about the electricity and water use of data centers, preventing consumers from realizing that increased utility costs are often associated with the arrival of energy-intensive facilities. By keeping usage data confidential or vaguely reported, corporations and policymakers avoid public scrutiny, even as these facilities strain local resources. Without clear disclosures, residents remain unaware of how much water is diverted for cooling systems or how much electricity is consumed—information that could help communities

push for fairer cost distribution or sustainable practices.

This lack of accountability allows data center operators to expand rapidly while shifting the financial and environmental burdens onto utility customers. As a result, many residents must pay higher bills without understanding the cause, leaving them unable to advocate for better regulations or compensation.¹⁵ The financial strain caused by data centers most severely impacts lower-income households, whose utility bills represent a disproportionate share of their income, exacerbating economic inequality in the region.



Photo credit: agnormark - stock.adobe.com

While communities face higher bills, data centers frequently negotiate lower rates through bulk Power Purchasing Agreements (PPAs) with investor-owned utility companies.¹⁶ These agreements allow data centers to operate at reduced costs despite their massive energy consumption, further shifting the financial burden onto local households and businesses. In August 2024, Meta signed two long-term PPAs with German power producer RWE for a combined 374 megawatt production in Illinois and Louisiana.¹⁷ Despite solar PPA prices holding steady, energy prices for residential consumers have increased by 20.7% in Clark County, Illinois,

and 39.0% in Laffite, Louisiana.¹⁸ Data centers and utility companies frequently collaborate to lobby state regulators for rate increases, exacerbating the disparity. In Michigan, DTE and Switch have spent over \$2 million lobbying the state house, senate, and Public Service Commission to raise electric rates; residential electricity rates have increased by 25% since the construction of the Switch data center in 2017 and are now 17% higher than the national average.¹⁹ This figure has yet to include the additional \$217.4 million rate hike approved by the Michigan Public Service Commission this year.²⁰ This dynamic leaves communities bearing the brunt of higher utility prices without reaping the economic benefits promised by data center development.

Data Centers Keep Fossil Fuel Plants Open

The rapidly growing energy demands of data centers have forced states to delay the retirement of coal and gas plants and even consider building new fossil fuel facilities.

Michigan

Data centers undermine Michigan’s climate plan by increasing electricity demand to a level that justifies keeping fossil fuel plants online. The state’s climate law includes an “offramp” provision, allowing fossil fuel generation to continue if renewable energy capacity is insufficient.²¹ As artificial intelligence and cloud computing drive higher energy consumption, utilities like Consumers Energy have warned that meeting renewable portfolio standards may become more challenging. Similar data centers have derailed climate goals in other states.²²



Photo credit: Parilov - stock.adobe.com

Virginia

Data centers have prolonged the use of coal and led to new natural gas proposals in Virginia.²³ PJM Interconnection announced that Virginia’s coal power plants will continue

operating to meet electricity requirements of data centers while waiting for renewable energy infrastructure to catch up. This situation is especially acute in Virginia, which hosts about half of all U.S. data centers and faces projected power demand increases of 85% over the next 15 years.²⁴ While renewable energy projects, like the Sumitomo Corp’s 1.5 gigawatt solar and battery initiative are being developed, the immediate power requirements are so substantial that coal plants in West Virginia and Maryland are being kept operational well beyond their planned retirement dates.²⁵ PJM Interconnection has proposed a \$5.9 billion project to build new transmission lines that would deliver electricity across multiple states to Virginia.²⁶ The transmission network would transport power from several West Virginia coal plants that are scheduled to shut down.

Nebraska

The 644-MW North Omaha Station coal plant, originally scheduled to close in 2023, will now remain active until at least 2026 due to increased power needs from nearby data centers.²⁷ Meta’s facility alone consumes nearly as much power as the entire North Omaha station produces, while Google’s data center in Papillon is an even larger power consumer. The problem is compounded by local resistance to renewable energy projects and regulatory hurdles slowing the transition to natural gas. Meanwhile, state officials have actively courted these tech companies with special electricity rates.

Utah

Lawmakers in Utah have cited the power demands of data centers as justification for extending the life of the Intermountain Power Project coal plant.²⁸ This trend is part of a broader strategy where tech companies are

repurposing coal sites to power data centers, attracted by their existing infrastructure including power lines, water access, and workforce availability.

Georgia

Georgia Power, facing power shortages by 2025 due to increasing data center development, has arranged to purchase 750 MW of electricity from Mississippi Power's Plant Daniel, which was originally scheduled to retire its coal units in 2027.²⁹ This arrangement will extend the life of inefficient 50-year-old coal-burning facilities for an additional 5–10 years.

Washington

Since the state's hydropower capacity is reaching its limits, counties are increasingly forced to rely on energy from the open market, where utilities buy electricity from a mix of carbon-emitting energy sources to meet the growing demand. In Grant County, Washington, data centers now account for nearly 40% of the county's total electricity demand, equivalent to the power used by 190,000 households.³⁰ To meet this demand, utilities have been forced to rely on "unspecified" power sources, which include fossil fuels like natural gas, purchased from the open market. This shift has reduced the share of renewable energy in the state's power mix, despite Washington's ambitious clean energy goals. The finite capacity of hydropower, combined with the rapid growth of data centers, has created a situation where utilities must either risk blackouts or continue to depend on fossil fuels to meet energy needs.

Indiana

Indiana's House Bill 1007 will keep coal and gas plants running while subsidizing small nuclear reactors to guarantee the power supply for AI data centers.³¹ The bill creates financial incentives for SMR (Small Modular Reactors) development through tax credits funded by energy generation cost savings brought about by keeping fossil fuel plants online. Additional provisions will keep fossil fuel plants open for even longer, even when they are

economically or environmentally unviable, by requiring regulatory reviews before any major retirements. If regulators determine that retiring a plant would threaten grid reliability, utilities will be barred from shutting it down and allowed to pass the full cost of continued operation onto consumers through rate hikes. At the same time, the bill encourages utilities to fast-track new generation projects to meet surging demand from data centers. These investments will further drive up electricity prices as the costs of construction, subsidies, and guaranteed returns for utilities are recovered from ratepayers. By prioritizing uninterrupted power for large corporate consumers over a managed transition to cleaner energy, the bill locks Indiana into higher electric rates and prolonged dependence on fossil fuels, leaving households and small businesses to bear the financial burden.

Michigan recently passed a data center tax exemption bill; what is in it?

Public Act 207 of 2024 grants tax exemptions for data center equipment purchases for brownfield sites (sites that are previously developed properties that are abandoned, underutilized, or contaminated due to past industrial or commercial activities) until 2050 or 2065.³² These exemptions apply to both the construction and operational phases of data centers. To qualify, facilities must meet certain criteria, including capital investment of at least \$250 million and creating at least 30 jobs that pay 150% of the region's median wage.



Photo credit: New Africa - stock.adobe.com

The tax breaks will reduce state revenue, raise utility prices for local communities, and create minimal employment benefits for a niche industry with limited job creation potential. AI data centers typically have lifespans of around 15-20 years.³³ A tax exemption for qualifying data centers until 2050 is expected to completely exempt these facilities from all construction and operating taxes throughout their life cycle.

The increased demand for resources by data centers strains local grids, which leads utilities to invest in infrastructure upgrades while passing the costs to

consumers through higher rates. Some data centers negotiate special rates or exemptions, creating a situation where other customers, including households, bear the cost of maintaining the grid's stability.

In Grand Rapids, a data center is already contributing to higher utility prices for residents. Since the construction of the Switch data center in 2015, the city has announced its 10th consecutive year of water supply rate increases for households, averaging an increase of 3.438% annually, a 49% greater increase than the statewide average during the same period.³⁴ Meanwhile, Switch has secured a 22-site, 200-megawatt, tax-exempt utility deal with Consumers Energy with plans to expand further starting January 2025.³⁵ The construction of the data center has enabled DigitalBridge, the parent company of Switch, to exploit the favorable regulatory environment while shifting the costs to residential consumers.

Policy Recommendations For States With Existing Tax Breaks

There are currently no state or federal laws that directly restrict or deter the construction of data centers. Over a dozen states have implemented tax break laws specifically designed to incentivize their development. The rapid expansion of data centers has also placed a strain on local utility and grid infrastructure. In all states with data center tax breaks, households who share utility and grid infrastructures with data centers have been pushed toward relying more on non-renewable energy sources and have experienced higher electricity rates.³⁶

States with existing tax breaks for data centers should consider adopting elements from the model laws described below. The strongest of these laws is the German Energy Efficiency Act.



Photo credit: Thongsuk - stock.adobe.com

California SB 57: Data center tariffs

California's Ratepayer and Technological Innovation Protection Act would impose specific requirements on data centers to align with California's climate and grid reliability goals. By July 1, 2026, data centers would need to operate under a special tariff system designed to ensure they do not shift costs to other ratepayers. Data centers would also be required to enter into 12-

year binding contracts to cover transmission and distribution costs, with provisions for exit fees and insurance bonds to mitigate financial risks if they cease operations or underutilize energy. They would need to prepay for necessary grid infrastructure upgrades in exchange for expedited interconnection, with potential reimbursement over time. By January 1, 2030, 100% of electricity delivered to data centers would need to come from zero-carbon resources, without increasing emissions elsewhere in the western grid. The bill would define data centers as large-scale energy consumers which house servers and related equipment for data processing, storage, and distribution.³⁷

California SB 222: Data center energy usage reporting and modeling

California's SB 222 would mandate that data centers estimate and report the total energy used for developing "covered models" (AI models requiring significant computing power) to developers upon contract termination or request. Developers would be required to publish this energy usage data on their websites before commercial use or third-party availability. The bill would also require data center operators to annually report energy consumption and performance data to the California Energy Commission, including metrics on total energy use, efficiency, renewable energy usage, and energy used for AI development. The commission would set energy efficiency standards for data centers, prioritizing cost-effectiveness, technological feasibility, and alignment with California's greenhouse gas reduction targets, while requiring new or significantly altered data centers to incorporate load-management and demand response capabilities.³⁸

Virginia SB1234: Prohibiting data center costs from being passed on to customers

Virginia's SB1234 would establish a provision to regulate how costs associated with the construction or extension of electric distribution infrastructure for data centers are handled. The bill stipulates that no costs related to building or expanding such infrastructure can be allocated to or recovered from any other utility customer. This includes expenses for land acquisition tied to the infrastructure. This means that the financial responsibility for these costs must fall entirely on the data center or the entity benefiting from the infrastructure and cannot be passed on to other customers through their utility rates or charges. The provision aims to ensure that other customers are not burdened with the costs of infrastructure projects that primarily serve data centers.³⁹

Virginia HB2578: Retail sales and use tax for data centers

HB 2578 would expand eligibility requirements for their existing sales and use tax exemption by mandating that data centers purchase a certain percentage of their annual electric load from clean energy resources and demonstrate sufficient investment in energy efficiency measures that provide system-wide benefits. It would also require that backup generators meet specific emissions standards. It would require the Commission on Electric Utility Regulation to examine the cost and feasibility of data centers using non-diesel-fired, onsite backup and primary generation and report their findings to the General Assembly. The Department of Energy would be tasked with identifying opportunities for the beneficial use of data center waste heat, creating an interactive map of data centers and potential heat users, developing a strategic plan to accelerate heat reuse, designating an employee to lead these efforts,

and convening a stakeholder group to prepare a report for the General Assembly.⁴⁰



Photo credit: jeson - stock.adobe.com

The German Energy Efficiency Act

The German Energy Efficiency Act (Energieeffizienzgesetz, or EEffG) establishes a sustainable growth model for data centers. It mandates energy audits, performance standards, renewable energy use, and public reporting to drive sustainability and efficiency while supporting national energy transition goals. One major requirement is that large data centers must conduct regular energy audits to identify opportunities for reducing energy consumption and improving efficiency. The Act also mandates that data centers meet specific energy performance standards, encouraging the adoption of advanced cooling technologies, server virtualization, and other energy-saving measures. Operators of data centers are incentivized to use renewable energy sources, either through on-site generation or procurement from certified green energy providers. The Act further promotes transparency by requiring data centers to publicly report their energy usage and efficiency metrics. These provisions ensure that data centers contribute to Germany's broader energy transition

goals by minimizing their environmental impact while maintaining operational efficiency.⁴¹

Recommendation: Adopt the German Energy Efficiency Act model

States with existing data center tax breaks should adopt the German Energy Act model to most effectively deter the rapid expansion of data center construction. The act prioritizes the integration of renewable energy sources and imposes strict efficiency standards on data centers, ensuring that their growth does not disproportionately burden the grid or increase reliance on non-renewable energy. U.S. states that adopt similar provisions would require data centers benefiting from tax incentives to meet high energy efficiency benchmarks, invest in on-site renewable energy systems, and contribute to grid modernization efforts. This would not only mitigate the negative impacts on ratepayers but also ensure that data center growth aligns with broader climate and sustainability goals through renewable energy portfolio requirements.

One Step Further: Require new renewable energy production

To prevent the increased use of fossil fuels resulting from data center construction and operation, a policy should be implemented requiring data centers to produce or procure 100% of their energy from renewable sources. This mandate would ensure that data centers do not contribute to rising demand for non-renewable energy. To address the risk of data centers' monopolizing renewable energy supplies and shifting consumers onto fossil fuel-based grids, the policy should include a "renewable energy additionality" clause. This clause would require data centers to generate new renewable energy capacity (e.g., by building on-site solar farms or funding new wind projects) rather than relying on existing renewable infrastructure. This approach ensures that

data centers expand the overall supply of renewable energy rather than competing with consumers for limited resources. The policy should also include provisions for grid modernization and energy storage investments to stabilize renewable energy availability and prevent price spikes that could disproportionately affect consumers. By prioritizing both renewable energy procurement and expansion, this policy would support data center growth while safeguarding consumer access to clean energy.

If all else fails, repeal

If all other measures to manage the environmental and infrastructural impacts of data center growth prove ineffective, states retain the option to repeal tax breaks for future data center construction. Although repealing tax breaks would not encourage data center operators to prioritize sustainability, it would eliminate a policy that benefits companies at the expense of communities.

Policy Recommendation For States Without Data Center Tax Breaks

Do not enact data center tax breaks

For states that have not passed data center tax breaks, the most simple policy recommendation is to avoid implementing such incentives in the first place. Legislators should refrain from passing laws that grant tax breaks to data centers, as these incentives often fail to deliver promised economic benefits and impose significant costs on state and local budgets. Despite claims of job creation, data centers typically generate few permanent positions relative to the scale of public subsidy they receive. The high energy consumption and environmental impact of data centers can strain local infrastructure and undermine climate goals. Redirecting public resources toward initiatives with more substantial and equitable economic returns, such as education, workforce development, or renewable energy, offers a more responsible and effective use of taxpayer dollars.

Endnotes

1. Anne-Laure Ligozat and Alex De Vries, “Generative AI: energy consumption soars,” *Polytechnique insights*, November 13, 2024, <https://www.polytechnique-insights.com/en/columns/energy/generative-ai-energy-consumption-soars/>.
2. Maria Korolov, “Data Centers Warm up to Liquid Cooling,” *Network World*, April 1, 2024, <https://www.networkworld.com/article/2076039/data-centers-warm-up-to-liquid-cooling.html>.
3. “DOE Releases New Report Evaluating Increase in Electricity Demand from Data Centers,” Department of Energy, December 20, 2024, <https://www.energy.gov/articles/doe-releases-new-report-evaluating-increase-electricity-demand-data-centers>.
4. Michael Copley, “Data Centers, Backbone of the Digital Economy, Face Water Scarcity and Climate Risk,” *NPR*, August 30, 2022, <https://www.npr.org/2022/08/30/1119938708/data-centers-backbone-of-the-digital-economy-face-water-scarcity-and-climate-ris>.
5. Pallavi Rao, “Ranked: Google’s Thirstiest Data Centers,” *Visual Capitalist*, February 4, 2025, <https://www.visualcapitalist.com/mapped-googles-data-centers-water-use/>.
6. Julia Borgini, “Data Center Cooling Systems and Technologies and How They Work,” *TechTarget*, November 8, 2024, <https://www.techtarget.com/searchdatacenter/tip/Data-center-cooling-systems-and-technologies-and-how-they-work>.
7. “Small Modular Reactors,” IAEA, April 13, 2016, <https://www.iaea.org/topics/small-modular-reactors>.
8. Andrew Leahey, “Tax Breaks For Data Centers Bring Few Jobs,” *Forbes*, August 13, 2024, <https://www.forbes.com/sites/andrewleahey/2024/08/13/tax-breaks-for-data-centers-bring-few-jobs/>.
9. Lulu Ramadan and Sydney Brownstone, “How a Washington Tax Break for Data Centers Snowballed Into One of the State’s Biggest Corporate Giveaways,” *ProPublica*, August, 4, 2024, <https://www.propublica.org/article/washington-data-centers-tech-jobs-tax-break>.
10. Karen Weise, “A.I., the Electricians and the Boom Towns of Central Washington,” *The New York Times*, December 25, 2024, <https://www.nytimes.com/2024/12/25/technology/ai-data-centers-electricians.html>.
11. J. Dale Shoemaker, “IDA Considering Massive Subsidies for STAMP Data Center,” *Investigative Post*, February 3, 2025, <https://www.investigativepost.org/2025/02/03/prospect-of-huge-subsidies-for-data-center-at-stamp/>.
12. Brian McVicar, “Schools, Switch Data Center Sign Agreement Resolving Tax Dispute,” *Mlive*, December 23, 2019, <https://www.mlive.com/news/grand-rapids/2019/12/schools-switch-data-center-sign-agreement-resolving-tax-dispute.html>.
13. “House Bill 4906 of 2023 (Public Act 207 of 2024) - Michigan Legislature,” Accessed May 5, 2025, <https://legislature.mi.gov/Bills/Bill?ObjectName=2023-HB-4906>.
14. Evan Halper and Caroline O’Donavan, “As data centers for AI strain the power grid, bills rise for everyday customers,” *The Washington Post*, November 1, 2024, <https://www.washingtonpost.com/business/2024/11/01/ai-data-centers-electricity-bills-google-amazon>.
15. Justin Lindemann, “With Load Growth and Fear of Rising Utility Bills, Are Low-Income Customers Protected?” *DSIRE Insight*, July 26, 2024, <https://www.dsireinsight.com/blog/2024/7/9/with-load-growth-and-fear-of-rising-utility-bills-are-low-income-customers-protected>.
16. European Investment Advisory Hub, “Commercial Power Purchase Agreements,” Accessed May 5, 2025, <https://advisory.eib.org/files/publications/attachments/commercial-power-purchase-agreements.pdf>.
17. Susan Lahey, “Meta Signs PPAs with RWE to Power Data Centers, Offices from New U.S. Solar Farms,” *ESG Today*, August 15, 2024, <https://www.esgtoday.com/meta-signs-ppas-with-rwe-to-power-data-centers-offices-from-new-u-s-solar-farms/>.
18. Find Energy, “Electric Rates & Providers in Orleans Parish, LA,” Accessed May 5, 2025, <https://findenergy.com/la/orleans-parish-electricity/>.
19. U.S. Energy Information Administration, “Electricity Data Browser - Average retail price of electricity,” Accessed July 15, 2025, <https://www.eia.gov/electricity/data/browser/#/topic/7?agg=0,1&geo=g0004&endsec=vg&freq=A&start=2001&end=2024&ctype=linechart<ype=pin&rtype=s&maptype=0&rse=0&pin=>
20. Paul Egan, “Michigan Panel Approves \$217.4 Million Electricity Rate Increase for DTE Energy,” *Detroit Free Press*, January 23, 2025, <https://www.freepress.com/story/news/local/michigan/2025/01/23/dte-energy-electricity-rate-increase/77902658007/>.
21. “House Bill 4906 of 2023 (Public Act 207 of 2024) - Michigan Legislature,” Accessed May 5, 2025, <https://legislature.mi.gov/Bills/Bill?ObjectName=2023-HB-4906>.
22. Ethan Howland, “Consumers Energy to Exit Coal-Fired Generation in 2025 under Agreement with Michigan AG,” *Utility Dive*, April 21, 2022, <https://www.utilitydive.com/news/consumers-energy-threatens-coal-retirement-plans-irp-michigan-psc/620391/>.
23. Darrell Proctor, “Power Demand from Data Centers Keeping Coal-Fired Plants Online,” *POWER*, October 17, 2024, <https://live-powermag.pantheonsite.io/power-demand-from-data-centers-keeping-coal-fired-plants-online/>.

24. Mac Carey, "How Data Center Alley Is Changing Northern Virginia," *Oxford American*, January 17, 2025, <https://oxfordamerican.org/oa-now/how-data-center-alley-is-changing-northern-virginia>.
25. Sumitomo Corporation of Americas, "Sumitomo Corporation Group Establishes Joint Venture to Develop Renewable Energy Projects in Virginia; Expanding Over 1.5 GW of Solar Power Projects in a Key IT Infrastructure Hub and Data Center Cluster," PR Newswire, October 15, 2024, <https://www.prnewswire.com/news-releases/sumitomo-corporation-group-establishes-joint-venture-to-develop-renewable-energy-projects-in-virginia-expanding-over-1-5-gw-of-solar-power-projects-in-a-key-it-infrastructure-hub-and-data-center-cluster-302275651.html>.
26. Zachary Skidmore, "PJM Approves \$5.9bn in New Transmission Projects to Support Data Centers," *Data Center Dynamics*, March 4, 2025, <https://www.datacenterdynamics.com/en/news/pjm-approves-59bn-in-new-transmission-projects-to-support-data-centers/>.
27. Darrell Proctor, "Power Demand from Data Centers Keeping Coal-Fired Plants Online," *POWER*, October 17, 2024, <https://live-powermag.pantheonsite.io/power-demand-from-data-centers-keeping-coal-fired-plants-online/>.
28. Alixel Cabrera, "Amid Tense Debate, Legislature Approves Plan to Keep Coal Plant Open," *Utah News Dispatch*, February 29, 2024, <https://utahnewsdispatch.com/2024/02/29/legislature-approves-plan-keep-coal-plant-open/>.
29. Emily Jones and Guatama Mehta, "Why Mississippi Coal Is Powering Georgia's Data Centers," *The Current*, August 27, 2024, <http://thecurrentga.org/2024/08/27/why-mississippi-coal-is-powering-georgias-data-centers/>.
30. Sydney Brownstone and Lulu Ramadan, "Ferguson Signs Executive Order to Look at Data Centers after Seattle Times-ProPublica Investigation," *The Seattle Times*, February 4, 2025, <https://www.seattletimes.com/seattle-news/times-watchdog/wa-governor-orders-team-to-study-data-centers-environmental-and-jobs-impact/>.
31. Rebecca Thiele, "House Passes Measure to Bolster Nuclear, Retain Coal for AI Data Centers on Utility Customer Dime," *WFYI Public Media*, February 13, 2025, <https://www.wfyi.org/news/articles/house-passes-measure-to-bolster-nuclear-retain-coal-for-ai-data-centers-on-utility-customer-dime>.
32. "House Bill 4906 of 2023 (Public Act 207 of 2024) - Michigan Legislature," Accessed May 5, 2025, <https://legislature.mi.gov/Bills/Bill?ObjectName=2023-HB-4906>.
33. Peter Judge, "The data center life story," *Data Center Dynamics*, July 21, 2017, <https://www.datacenterdynamics.com/en/analysis/the-data-center-life-story/>.
34. Anne Snabes, "GLWA Bows to Public Pressure, Raises Water, Sewer Rates Less," *The Detroit News*, February 26, 2025, <https://www.detroitnews.com/story/news/local/michigan/2025/02/26/great-lakes-water-authority-to-weigh-water-sewer-rate-hikes-wednesday/80475435007/>.
35. Ron Starner, "Turning the Switch On," *Site Selection*, June 1, 2017, <https://siteselection.com/turning-the-switch-on/>.
36. Robert Walton, "AI, Data Center Load Could Drive 'Extraordinary' Rise in US Electricity Bills: Bain Analyst," *Utility Dive*, February 26, 2025, <https://www.utilitydive.com/news/data-center-load-growth-us-electricity-bills-bain/730691/>.
37. "SB 57: Electrical Corporations: Tariffs," *Digital Democracy*, Accessed May 5, 2025. https://calmatters.digitaldemocracy.org/bills/ca_202520260sb57.
38. "SB 222: Climate disasters: civil actions," *Digital Democracy*, Accessed May 5, 2025. https://calmatters.digitaldemocracy.org/bills/ca_202520260sb222.
39. "SB1243 Electric utilities; electric distribution infrastructure serving data centers," Legislative Information System, Accessed May 5, 2025, <https://lis.virginia.gov/bill-details/20251/SB1243>.
40. "HB2578 Retail Sales and Use Tax; exemption for data centers, reports," Legislative Information System, Accessed May 5, 2025, <https://lis.virginia.gov/bill-details/20251/HB2578>.
41. Carlos Robles y Zepf and Dr. Philipp Schaefer, "Sustainable Data Centers—The German Energy Efficiency Act: What Data Center Operators Need to Consider Now and in the Future," *Mayer Brown*, February 19, 2024, <https://www.mayerbrown.com/en/insights/publications/2024/02/sustainable-data-centers-the-german-energy-efficiency-act-what-data-center-operators-need-to-consider-now-and-in-the-future>.

Data Centers — A threat to Minnesota's water

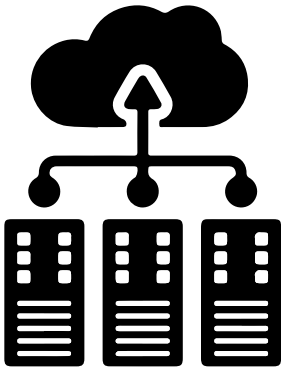

*Data centers are popping up across the country as the dependency on cloud computing and Artificial Intelligence increases. These centers require millions of gallons of water and huge amounts of electricity each year to cool the facility and run efficiently. This can cause stress in areas experiencing water scarcity and water quality concerns. **Minnesota is currently home to 61 data centers.***

Minnesota must demand that:

- Multi-billion-dollar businesses pay their fair share in taxes. This means paying local and state taxes as well as a tax on every gallon of potable water used.
- Centers use the safest, most environmentally friendly options when cooling and descaling the facility. Centers must provide a report to the legislature annually that they are using the safest, most up-to-date technology.
- Any data center operating in Minnesota must report their water usage to the legislature and publicly on their website annually.
- Centers construct their own carbon-free power generation facilities onsite to power their electricity and cooling demands.
- Require data centers to reuse and recycle all water in their cooling systems. The state should be compensated per gallon of potable water used to run and maintain data centers.



Data Center in Ashburn, Virginia.

Data Center Facts:

- Data centers rely on water-intensive cooling systems that consume millions of gallons of drinking water each year. A single data center can consume up to 5 million gallons of water per day.¹
- Data centers are increasing their need for fresh water over time — Microsoft’s water consumption increased by 34% between 2021 and 2022². Google’s water consumption went up nearly 22% over the same period to 5.56 billion gallons per year.⁵
- The water used in data centers is often treated with chemicals to prevent corrosion and bacterial growth, rendering it unsuitable for human consumption or agricultural use. This means that not only are data centers consuming large quantities of drinking water, but they are also effectively removing it from the water cycle.³
- Data centers operate 24/7/365 — and there are an estimated 5,300 facilities in the United States. This adds up to hundreds of billions of gallons of water used each year.⁴
- One AI query is estimated to use 16 ounces of fresh water.⁵ ChatGPT estimates upwards of 10 million queries per day.



Data Centers and PFAS — a dangerous combination

Data centers use a variety of chemicals in their cooling system, chemicals that contaminate water as it works through the data center cooling system:

- **Refrigerants:** Fluorinated gases (F-gases), specifically hydrofluoroolefins (HFOs) and hydrochlorofluoroolefins (HCFOs) — which are types of PFAS
- **Cooling loop chemicals:** Ethylene Glycol — a clear, odorless, flammable, and toxic liquid that is used in antifreeze and other products
- **Water treatment chemicals:** Corrosion inhibitors such as nitrites, molybdates, borates, azoles (for protecting yellow metals), phosphates, and polymers are commonly used, descalers, and hydrogen peroxide (the most environmentally friendly option).

Minnesotans shouldn’t be left on the hook for multi-billion-dollar companies seeking tax breaks to run facilities that not only monopolize but also poison our water.

Company	Annual Profits	Annual Revenue	Water used in Data Centers (most recent reporting)
Google	\$30.7 billion	\$350 billion ⁶	5.6 billion gallons
Microsoft	\$88.14 billion	\$261 billion ⁷	33 million gallons
Meta	\$62.36 billion	\$164 billion ⁸	5.8 million gallons
Equinix	\$4.281 billion	\$8.7 billion ⁹	1.5 million gallons

1 <https://utulsa.edu/news/data-centers-draining-resources-in-water-stressed-communities/#:~:text=Unfortunately%2C%20many%20data%20centers%20rely,thousands%20of%20households%20or%20farms.>

2 ibid

3 ibid

4 <https://www.asce.org/publications-and-news/civil-engineering-source/civil-engineering-magazine/issues/magazine-issue/article/2024/03/engineers-often-need-a-lot-of-water-to-keep-data-centers-cool>

5 <https://www.watertechnologies.com/blog/artificial-intelligence-using-ton-water-heres-how-be-more-resourceful#:~:text=The%20technology%20is%20constantly%20evolving,that%20house%20these%20AI%20systems.>

6 <https://companiesmarketcap.com/alphabet-google/revenue/>

7 <https://www.statista.com/statistics/267808/net-income-of-microsoft-since-2002/>

8 <https://www.statista.com/statistics/277229/facebooks-annual-revenue-and-net-income/#:~:text=Meta%3A%20annual%20revenue%20and%20net%20income%202007%2D2024&text=In%202024%2C%20Meta%20Platforms%20generated,to%20114%20billion%20U.S.%20dollars.>

9 <https://investor.equinix.com/news-events/press-releases/detail/1063/equinix-reports-strong-fourth-quarter-and-full-year-2024>

FOR MORE INFORMATION:

Avonna Starck, Minnesota State Director, Clean Water Action and Clean Water Fund, AStarck@cleanwater.org or 612.423.6939
125 SE Main Street, Suite 135, Minneapolis, MN 55415 • Tel: (612) 623-3666 • www.cleanwateraction.org/mn

HUSCH BLACKWELL

Charles G. Renner
Partner

4801 Main Street, Suite 1000
Kansas City, MO 64112
Direct: 816.329.4702
Fax: 816.421.0596
charles.renner@huschblackwell.com

May 12, 2026

Edgerton City Clerk
Dusti Callahan
City of Edgerton, Kansas
404 E Nelson Street
Edgerton, KS 66021

Re: Letter of Support - DAMAC Digital Solutions Kansas – Heartland Data Center -
Preliminary Plat (PP2026-0001) & Site Plan (FSP2026-0002) Approval

Dear Members of the Planning Commission and Neighborhood Planning and Development Board:

Husch Blackwell LLP serves as legal counsel to DAMAC Digital Solutions Kansas, LLC ("DAMAC") in connection with the above-referenced site plan application and preliminary plat for the development of a data center facility at 31800 West 196th Street, Edgerton, KS 66021. As DAMAC's attorneys, we have worked closely with DAMAC throughout the planning and development of this project, and we write in support of both applications. We respectfully urge the Board to approve the site plan and preliminary plat.

I. DAMAC'S APPROACH TO THIS PROJECT

DAMAC has approached the design and development of this project methodically and in great detail. Prior to filing the above-referenced applications, DAMAC identified potential community concerns, commissioned appropriate studies for various issues, engaged with relevant stakeholders, and incorporated mitigation measures into the project design from the outset. Rather than addressing concerns reactively, DAMAC has proactively incorporated measures to alleviate public concerns at every stage of development.

The result is a project that reflects careful planning and a genuine effort to ensure community impacts are minimized, and community benefits are real. The Board can be confident DAMAC understands its obligations and intends to meet them. This level of care and thoroughness is indicative of DAMAC's character as an organization and of the exceptional community partner DAMAC will be for the City of Edgerton.

City Clerk
May 12, 2026
Page 2

II. EDGERTON'S IDEAL DATA CENTER DEVELOPMENT

A. Retrofit of an Existing Vacant Building

This Project primarily involves the adaptive reuse of an appropriately zoned, vacant commercial building. The meaningful distinction between adaptive reuse as compared to fully greenfield development is relevant to the Board's consideration of both the site plan and the preliminary plat. From a community standpoint, a vacant industrial building within an established industrial park, well separated from residential areas, represents an ideal scenario for data center placement.

Retrofitting an existing structure offers several concrete advantages over greenfield development:

- **Minimal land disturbance.** The primary building footprint already exists, eliminating the need for large-scale clearing, grading, or loss of open space associated with ground-up data center construction. While the sub and switching station on the adjacent lot will require limited site development, the overall environmental impact of the development phase is substantially reduced compared to new construction of an entire data center facility on vacant land.
- **Reduced construction impacts.** With the core structure already in place, the scope of construction activity (truck traffic, noise, dust, and disruption to surrounding uses) is considerably less than a ground-up development would require.
- **Productive use of a vacant property.** Vacant and unused buildings can attract vandalism and create safety concerns, while generating limited economic activity for the community. This Project converts a dormant property into a functioning facility, significantly increasing property tax revenues and economic output beyond what the vacant property produced.
- **Efficient use of existing infrastructure.** Existing utility connections, access roads, and site improvements will be utilized and upgraded rather than constructed from scratch, reducing the need for new infrastructure in or adjacent to the surrounding area. The preliminary plat reflects this approach.
- **Sustainability.** Reusing an existing structure is widely recognized as a more sustainable development approach. It conserves the materials and energy already embedded in the building, avoids demolition and disposal costs, and reduces the Project's overall environmental footprint compared to ground-up construction.

B. Industrial Park Location

The facility is located within an established industrial park, surrounded by compatible industrial uses, and more than 1,000 feet from the nearest residential structure. The Project is an industrial use in an industrial setting, which is the appropriate context for this type of facility and is consistent with sound land use planning. Several aspects of this location are worth highlighting:

City Clerk
May 12, 2026
Page 3

- **Compatibility with surrounding uses.** The operational characteristics of a data center (mechanical equipment, periodic truck deliveries, and backup generator testing) are consistent with the existing uses in the surrounding industrial park. The preliminary plat reflects a lot configuration that is in keeping with the established subdivision pattern of the area.
- **Separation from residential areas.** The more-than-1,000-foot distance from the nearest residential structure means that noise, visual impact, and other operational effects will not reach residential neighbors. The concerns most commonly raised in residential-adjacent data center proposals are not applicable here.
- **No effect on residential neighborhoods or community character.** The Project does not introduce a new use into a residential or mixed-use context, does not alter the character of any neighborhood, and does not route construction or operational traffic through residential streets.

The combination of adaptive reuse of an existing vacant building and placement within an established industrial park, at a substantial distance from residential uses, addresses the most common objections to data center development. From a community perspective, this is an ideal scenario: the Project activates a dormant property, generates economic benefits, and operates in a setting where its characteristics are compatible with surrounding uses and do not burden residential neighborhoods. The site and the proposed use are a natural and appropriate fit.

III. ECONOMIC AND COMMUNITY BENEFITS

The Project will generate meaningful economic benefits for the City and surrounding community:

- **Jobs.** The Project will create local construction jobs and permanent full-time positions with competitive wages and benefits, as well as additional indirect employment through demand for local goods and services.
- **Tax Revenue.** The facility will generate substantial property tax revenue for the City, Johnson County, and local school districts.
- **Local Procurement.** DAMAC is committed to engaging local contractors, vendors, and service providers during construction and operations.
- **Digital Infrastructure.** Data centers support the services communities rely on daily: cloud computing, healthcare systems, financial services, and emergency communications. This facility contributes to the region's digital infrastructure in a tangible way.

HUSCH BLACKWELL

City Clerk
May 12, 2026
Page 4

IV. WATER, ENERGY, AND ENVIRONMENTAL CONSIDERATIONS

Water Use. The facility will use advanced closed-loop cooling technology designed to minimize water consumption. The Project has been coordinated with the local water authority and confirmed as supportable within the existing water supply system.

Energy and the Grid. DAMAC has coordinated with Evergy to ensure that the Project's power demands are supported by existing or planned grid capacity without affecting energy rates or reliability for existing customers.

Environmental Compatibility. Data centers do not regularly produce smoke, hazardous air pollutants, chemical waste, or industrial effluent. Noise from cooling equipment and backup generators has been addressed through engineered attenuation measures designed to comply with applicable noise ordinances. Given the industrial park setting and the distance from residential uses, impacts on sensitive receptors are not a concern. Backup generator fuel storage will be managed in compliance with all applicable environmental regulations, including secondary containment and spill prevention requirements.

V. CONCLUSION

The Project combines adaptive reuse of a vacant building, a well-suited industrial park location, meaningful separation from residential uses, and a responsible operational approach. Both the site plan and the preliminary plat are consistent with applicable regulations and the City's land use goals. DAMAC has approached this project carefully and has addressed the concerns most commonly associated with data center development.

We respectfully urge the Board to approve both the site plan application and the preliminary plat. We are available to answer any questions and look forward to the public hearing.

Respectfully,

HUSCH BLACKWELL LLP

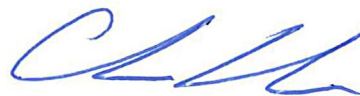

Charles G. Renner

FW: Planning Commission Meeting

From Donald Roberts <mayor@edgertonks.org>
Date Tue 5/12/2026 10:32 AM
To City Clerk Distribution List <cityclerk@edgertonks.org>



Internal (mayor@edgertonks.org)



[Safe](#) [Spam](#) [Phish](#) [More...](#)

From: Courtney Sappington <Courtney.Sappington@house.ks.gov>
Sent: Tuesday, May 12, 2026 10:26 AM
To: Donald Roberts <mayor@edgertonks.org>
Cc: Clay Longanecker <clonganecker@edgertonks.org>; Josh Lewis <jlewis@edgertonks.org>; Ron Conus <rconus@edgertonks.org>; Bill Malloy <Bmalloy@edgertonks.org>; Deb Lebakken <dlebakken@edgertonks.org>; Community Development <CommunityDevelopment@edgertonks.org>
Subject: Planning Commission Meeting

[External Sender]

Mayor Roberts and City Councilmen and Women,

I wanted to reach out since I will be at the Planning Commission meeting tonight but I'll be late since I'm coming from a KDOT meeting in Wellsville. As the representative for Edgerton citizens and the surrounding community, I remain skeptical that any data center would be a good and viable project for this community.

I have several questions, particularly around the noise levels once operational, the effect on electric rates and the distortion of ground temperature. There are studies that show a great deal of heat released can affect up to a 3-5 mile radius.

Market analysts are already speculating on an industry bubble due to the amount of investor capital flowing into AI and data center production and the long-term application of this new technology is still murky and rapidly changing. SpaceX has also publicly touted its plan to deploy data centers in space in "constellations" of satellites. While this is still developing, it's not dismissive to consider that even in 10 years the output, resources and space required for these data centers will be massively diminished and improved. I would have hated to invest heavily in MySpace a few months before Facebook launched in the mid-2000s.

I ask you to consider the feedback from your residents, from the community at large, and consider the impacts on other nearby businesses, like New Life Christian Academy where my children attend school. These projects are massively unpopular with the public.

In the gospel of Mark, Jesus clarifies to his disciples and to the Pharisees that the Sabbath was made for man, not man for the Sabbath. I believe that these types of development projects should be made for our community, not the other way around. If their implementation leads to depressed home values, forces families away, and reduces quality of life, then it's not a rightly-ordered pursuit.

Thank you,

Courtney Sappington

Representing KS House District 5:

Portions of Douglas, Miami, Franklin & Johnson Counties

Courtney.Sappington@house.ks.gov

(816) 225-1236

167W

data center

From dpearce44@aol.com <dpearce44@aol.com>
Date Mon 5/11/2026 3:53 PM
To City Clerk Distribution List <cityclerk@edgertonks.org>



Caution: External (dpearce44@aol.com)
First-Time Sender [Details](#)



[Safe](#) [Spam](#) [Phish](#) [More...](#)

[External Sender]

Planning commission and council members.

Although i am not a citizen of Edgerton i do own 6 rental homes and 17 acres in the citycore. *am speaking for my six families.*

I am sure that after doing your homework on the data center that you know that it does more harm than good. High water usage,high electric usage,a constant hum and on and on. Please do as your neighboring towns have done. Follow Springhill and Gardner officials and reject the data center..

China is buying up land in iMissouri,do not let Dubai of the middle east buy up land and place data centers in the city of Edgerton.

Thank you, Donna Pearce



May 12, 2026

Edgerton City Planning Commission
Attn: Dusti Callahan, Edgerton City Clerk
Edgerton City Hall
404 E Nelson Street
Edgerton, KS
cityclerk@edgertonks.org

Dear Ms. Callahan:

I am writing on behalf of Evergy to express our strong support for the proposed DAMAC Digital data center project within Logistics Park Kansas City in Edgerton, Kansas. Repurposing the existing 400,000-square-foot industrial facility at 31800 W. 196th Street represents an \$860 million investment with transformational economic development opportunity for Edgerton and the surrounding region.

Data centers are a proven engine for economic growth, generating thousands of construction jobs, long-term high-skilled positions, and substantial new tax base for communities without a corresponding strain on public services. The reuse of an existing industrial building aligns well with Edgerton's land-use vision for Logistics Park Kansas City and represents an efficient and responsible development approach.

Beyond the immediate economic impact, data centers play a critical role in enabling the digital economy. They support advances in logistics, healthcare, advanced manufacturing, and artificial intelligence—industries that increasingly depend on secure, reliable, and proximate digital infrastructure. Investment at this scale signals confidence in Edgerton as a strategic location for technology-driven growth and helps attract additional employers and capital investment to the community.

Evergy recognizes that large energy users must be integrated thoughtfully and responsibly to protect existing customers. To that end, Evergy proposed, and the Kansas Corporation Commission approved a special electric rate for data centers called Large Load Power Service (LLPS) tariff that establishes strong consumer protections. Under this framework, data centers are required to pay 100 percent of the direct costs necessary to serve their facilities, pay premium electric rates that help fund new generation and transmission investments, and enter into long-term contracts with significant financial commitments. These provisions allow the community to benefit from new economic development while making sure residential and business customers are fully protected from costs and financial risk associated with these large loads.

In addition, data centers contribute materially to local revenues through property taxes, franchise fees on electric usage, and community partnerships that can support schools,

workforce development, and other local priorities. Modern data centers are also increasingly efficient, utilizing advanced cooling technologies and infrastructure designed to minimize potential environmental impacts.

Evergy has the capacity, planning processes, and regulatory oversight in place to reliably serve new large-load customers while maintaining system reliability and affordability for all customers. Growth of this nature helps spread the fixed costs of maintaining and upgrading the electric grid across a broader customer base, helping to moderate long-term costs and slow the growth of electricity rates over time.

For these reasons, Evergy supports the approval of both the preliminary plat and final site plan for DAMAC Digital's data center project. We appreciate the City of Edgerton's careful consideration of this investment and its long-term benefits to the community.

Sincerely,

A handwritten signature in blue ink, appearing to read "Chuck Caisley". The signature is stylized and fluid, with the first name being more prominent.

Chuck Caisley
Executive Vice President of Utility Operations
Chief Customer Officer
Evergy

Public Comment May 12th, 2026 - opposition to DAMAC

From Jacy Norton <jmnorton3@gmail.com>

Date Thu 5/7/2026 11:02 AM

To City Clerk Distribution List <cityclerk@edgertonks.org>; Donald Roberts <mayor@edgertonks.org>; Clay Longanecker <clonganecker@edgertonks.org>; Josh Lewis <jlewis@edgertonks.org>; Ron Conus <rconus@edgertonks.org>; Bill Malloy <Bmalloy@edgertonks.org>; Deb Lebakken <dlebakken@edgertonks.org>; Community Development <CommunityDevelopment@edgertonks.org>; info@edgertonks.org <info@edgertonks.org>



Caution: External (jmnorton3@gmail.com)

First-Time Sender [Details](#)



[Safe](#) [Spam](#) [Phish](#) [More...](#)

[External Sender]

Hello,

I am a resident of Edgerton, KS and am writing to express my strong opposition to the proposed data center project at 38100 W 196th St.

My opposition is based on the following concerns:

- **High Utility Demands:** This project will place unprecedented strain on our local power and water infrastructure, likely increasing utility costs for residents.
- **Environmental & Noise Concerns:** The 24/7 noise from cooling systems and potential environmental risks threaten the quality of life in our surrounding neighborhood. Not to mention the impacts to local wildlife and 24/7 light pollution concerns.
- **Air Pollution:** Many centers use diesel generators for backup power, which emit harmful nitrogen oxides and pollutants associated with asthma and cancer.
- **Extremely Low Job-to-Subsidy Ratio:** Data centers are highly automated, creating very few permanent jobs, yet they often receive millions in subsidies. Tax incentives take money away from essential services like schools, libraries, and public safety. This money should be invested in the community rather than subsidizing large technology corporations.

I urge you to vote NO on any zoning changes, tax incentives, or permits related to this project. We need to prioritize community well-being over corporate demand.

I would like this read aloud for public comment during the May 12th 7PM meeting.

Thank you for your time and for representing our community.

Jacy Norton

Proposed Data Center at Logistics Park Kansas City

From James Oltman <james@elevateedgerton.com>

Date Mon 5/11/2026 3:31 PM

To James Oltman <james@elevateedgerton.com>

Cc Dusti Callahan <dcallahan@edgertonks.org>; Tina Mathos <tmathos@edgertonks.org>; Jeremy Little <jlittle@edgertonks.org>; Ray Soemer <rsoemer@edgertonks.org>; Jordyn Mueller <jmueller@edgertonks.org>; Adam Draskovich <adraskovich@edgertonks.org>

 1 attachment (129 KB)

DC PC Letter.pdf;



External (james@elevateedgerton.com)



[Safe](#) [Spam](#) [Phish](#) [More...](#)

[External Sender]

Good afternoon Edgerton Planning Commissioners –

Please find attached a letter outlining some comments that I have about the proposed Data Center at Logistics Park Kansas City being considered at tomorrow nights Planning Commission meeting. Please don't hesitate to let me know if you have any questions.

Thank you!



James Oltman – President
30750 W 193rd St.
Edgerton, KS 66030
james@elevateedgerton.com
913.882.2500
402.499.6829 c



Dear Members of the Edgerton Planning Commission,

I am writing regarding the proposed data center project being considered within Logistics Park Kansas City in Edgerton. I believe it is important to recognize that this proposal is fundamentally different from several of the larger-scale data center projects that have recently drawn public attention throughout the region. This proposed project while different is also set to provide a significant number of benefits to the Edgerton Community and its residents.

First and foremost, this is not a hyperscale data center campus. The proposal involves the reuse of a single existing industrial building located within an already-developed industrial environment. Unlike many large-scale data center developments that require extensive construction, this project would utilize an existing structure and existing infrastructure within the park.

Additionally, this type of project is already a permitted use under the current zoning classification. This is not a request to change the long-term vision or intended land use of the Logistics Park area. Rather, it is a proposal that fits within the uses already contemplated and allowed within the existing zoning framework established by the community. As you know, governing officials, city staff, and community members recently went through an intensive and deliberate process to update Edgerton's comprehensive plan and the future land use map. During and after the process much consideration was given to listening to the community's desire (and much input was given) to keep future industrial development away from the residential community and within Logistics Park Kansas City.

Equally important is the project's location. The facility would be located entirely within the existing Logistics Park industrial area, surrounded by warehouses and other industrial uses that already define the character of the area. The proposed building is located more than five miles from the Edgerton residential community, creating substantial physical separation between the project and residents.

Lastly it would be unwise to overlook the benefits that this project will bring to the Edgerton community. This project will not only bring quality jobs, but jobs with average wages higher than what we see currently at LPKC. These jobs will span a variety of fields and be available to current and future community members.



In addition to high paying quality jobs, this facility will generate a significant amount of sales tax that will be collected. With the recent passage of a new community sales tax dedicated solely to street and stormwater projects, this facility would generate millions of dollars each year for improvements that will vastly improve the quality of life of our residents (like much needed improvements to the Horsehoe).

For these reasons, I respectfully encourage the Planning Commission to consider this proposal based on its actual characteristics and impacts, rather than through the lens of unrelated hyperscale projects proposed in other communities or under an entirely different false narrative. This proposal represents the use of an existing industrial building, within an established industrial park, under existing zoning regulations, and in a location substantially removed from residential areas while providing substantial benefits for the Edgerton Community.

Thank you for your time, consideration, and service to the community.

Sincerely,

James Oltman
ElevateEdgerton!

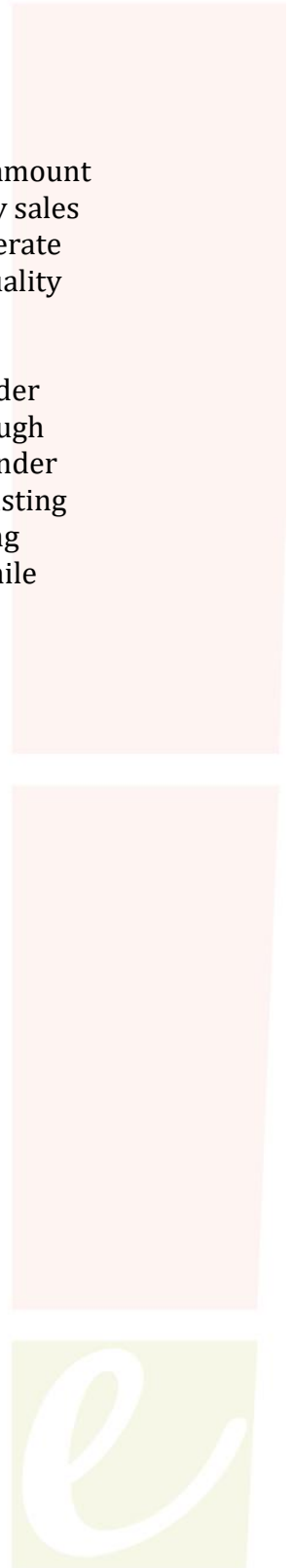

Comment for May 12 Planning Commission Meeting (PP2026-0001)

From Jason S <jasonswrs@gmail.com>

Date Mon 5/11/2026 2:28 PM

To City Clerk Distribution List <cityclerk@edgertonks.org>



External (jasonswrs@gmail.com)



[Safe](#) [Spam](#) [Phish](#) [More...](#)

[External Sender]

Jason Sowers
19911 Pepper Tree Ln
Edgerton, KS 66021

Edgerton City Council
404 East Nelson St
Edgerton, KS 66021

Dear Planning Commissioner Members of Edgerton,

I am writing to formally express my concerns and opposition regarding the proposed DAMAC Digital Data Center at 31800 W 196th Street. While the city has historically welcomed industrial development within Logistics Park Kansas City (LPKC), this specific project presents a unique profile of environmental risk and economic imbalance that has not been adequately addressed in the staff report or the applicant's Frequently Asked Questions. As someone who has been inside existing data centers, I am uniquely positioned to have seen the inner workings of these buildings.

1. Blowdown of Closed-loop Cooling System

The applicant claims a "closed-loop" cooling system with "near zero" water usage. This phrasing is technically narrow and potentially misleading. Even closed-loop systems [require regular "blowdown"](#) where an amount of water, typically monthly, is bled to remove concentrated mineral buildup, scale, and keep biological growth in check.

I ask the Commissions: Has a chemical analysis of the proposed blowdown water been provided to the City's wastewater treatment department? We cannot risk the introduction of chemically treated discharge into our local infrastructure or groundwater under the guise of a "sustainable" system.

2. Electricity Rate Increases for Residents

Data centers are among the most energy intensive structures on earth. While DAMAC is funding a switching station, the sheer magnitude of their draw on the regional grid often necessitates massive

infrastructure upgrades by Evergy. Evergy has made claims that data centers will pay 20% more than existing customers for their electricity. However, there is no mention of holding firm on the base rate the 20% will be applied to. History in other jurisdictions shows that these "grid-strengthening" costs are frequently passed on to the general rate-payer, despite what the brochure may claim.

3. Minimal Economic Return

The most concerning aspect of this proposal is the disproportionate trade-off between resource consumption and community benefit. This facility will occupy a massive footprint and consume significant public resources, yet it will yield **approximately 20 long-term jobs**.

In contrast to traditional logistics or manufacturing hubs that provide hundreds of opportunities for our workforce, a data center is essentially a "dark building." A collection of servers requiring only a skeleton crew of security and minimal IT staff. This results in [huge profit margins](#) of 50% or greater. Using our industrial-zoned land for a project that provides so few jobs while placing such a high strain on our utilities is not a sound long-term strategy for Edgerton's growth. DAMAC is asking for the city to facilitate a project that will generate tens of millions in annual profit for their company, while offering the city a few dozen jobs. We are taking all the environmental and utility risk while they take all the profit. Tax abatements and other incentives exacerbate this problem, as money that should be going to local schools, fire stations, municipal, police, and other local areas, go to large corporations that are out-of-state or worse, out of the country.

Conclusion

We are being asked to trade our water security, our grid stability, and our valuable land for a project that offers negligible employment & economic opportunities. I urge the Commission to vote no on both the Preliminary Plat (PP2026-0001) and Final Site Plan (FSP 2026-0002) for DAMAC Digital.

Sincerely,

Jason Sowers



Union Station Kansas City
30 W. Pershing Road | Suite 200
Kansas City, MO 64108
816.221.2121

May 12, 2026

Ms. Dusti Callahan, City Clerk
City of Edgerton
404 East Nelson Street
Edgerton, Kansas

RE: Planning Commission Meeting – May 12, 2026
DAMAC Digital
Items: PP2026-0001 and FSP2026-0002

Dear Commission Members,

My name is Jill McCarthy. I serve as Senior Vice President of Corporate Attraction for the Kansas City Area Development Council (KCADC). KCADC is the regional economic development organization representing 18 counties and more than 50 communities across the bi-state KC region. Our mission is to attract companies, capital investment and talent recruitment throughout Great Kansas City.

Today's proposed investment by DAMAC Digital represents a significant opportunity for both the City of Edgerton and the greater KC region. This project directly supports the accelerating growth in digital services, cloud computing, and advanced technologies that increasingly power our economy. Data centers today are providing the power infrastructure for manufacturing and residents alike.

Data centers are critical infrastructure. They support essential, everyday communications – such as email and video calls, streaming & social media – but much more than that, data centers are the backbone of the economy providing resilience and security for defense, education, emergency services, financial services, healthcare, and the rapidly expanding global race for AI.

KCADC is proud to partner with the City of Edgerton, ElevateEdgerton!, the Kansas Department of Commerce, NorthPoint Development and DAMAC Digital on this impactful project.

We appreciate the City's leadership and collaboration and look forward to advancing the next steps together.

Respectfully,

A handwritten signature in black ink, appearing to read "Jill McCarthy", with a long horizontal flourish extending to the right.

Jill McCarthy
SVP | Corporate Attraction
Kansas City Area Development Council
mccarthy@OneKC.org

Fwd: Urgent concerns regarding proposed data center

From Donald Roberts <mayor@edgertonks.org>
Date Mon 5/11/2026 7:27 AM
To City Clerk Distribution List <cityclerk@edgertonks.org>



Internal (mayor@edgertonks.org)



[Safe](#) [Spam](#) [Phish](#) [More...](#)

Sent from my iPhone

Begin forwarded message:

From: Kailey Dressler <kmesler@gmail.com>
Date: May 11, 2026 at 7:17:01 AM CDT
To: Donald Roberts <mayor@edgertonks.org>
Subject: Urgent concerns regarding proposed data center

[External Sender]

Dear Mayor Roberts,

All of a sudden, data centers are knocking at the doors of numerous communities across the country, and more recently, in Johnson County and surrounding neighborhoods. While they may look enticing at first pass with their promises of revenue and "mitigated" risk, it has more recently come to light that the data centers of today are not like anything we have seen before, and promises of risk mitigation from developers and data center companies are not only holding empty, but are completely false:

- EMF radiation is a huge, under recognized and extremely hazardous consequence of data centers, particularly for children. "Non-ionizing EMFs have been linked by credible peer-reviewed published scientific studies to childhood leukemia, central nervous system tumors, brain cancer, breast cancer, Alzheimer's disease, cognitive dysfunction, miscarriage, ADHD, obesity, asthma, oxidative stress, free radical formation, and DNA damage. Hundreds of scientists have called for risk mitigation measures to reduce public exposure to non-ionizing EMFs."

https://ehsciences.org/data-centers-increase-electromagnetic-fields-emf-exposure/?fbclid=IwY2xjawRuBCpleHRuA2FibQlxMABicmlkETFqeDVCQzVBTHlqYjRXeWNVc3J0YwZhcHBfaWQ_QMjlyMDM5MTc4ODlwMDg5MgABHgeOG8-JYZUP8Cz9PEhdKO4yDMVs-FHbSrcK9XBUAP3N8CAEx9Z_XDY1So0T_aem_QZla_moEa7a7-t8SEJ6AJg

While these problems affect everyone, the young and elderly are particularly susceptible to negative health impacts. There are over 6,500 students in multiple communities within a 5 mile radius of this proposed data center, with over half of those in elementary school and severely susceptible to negative health outcomes directly related to this center.

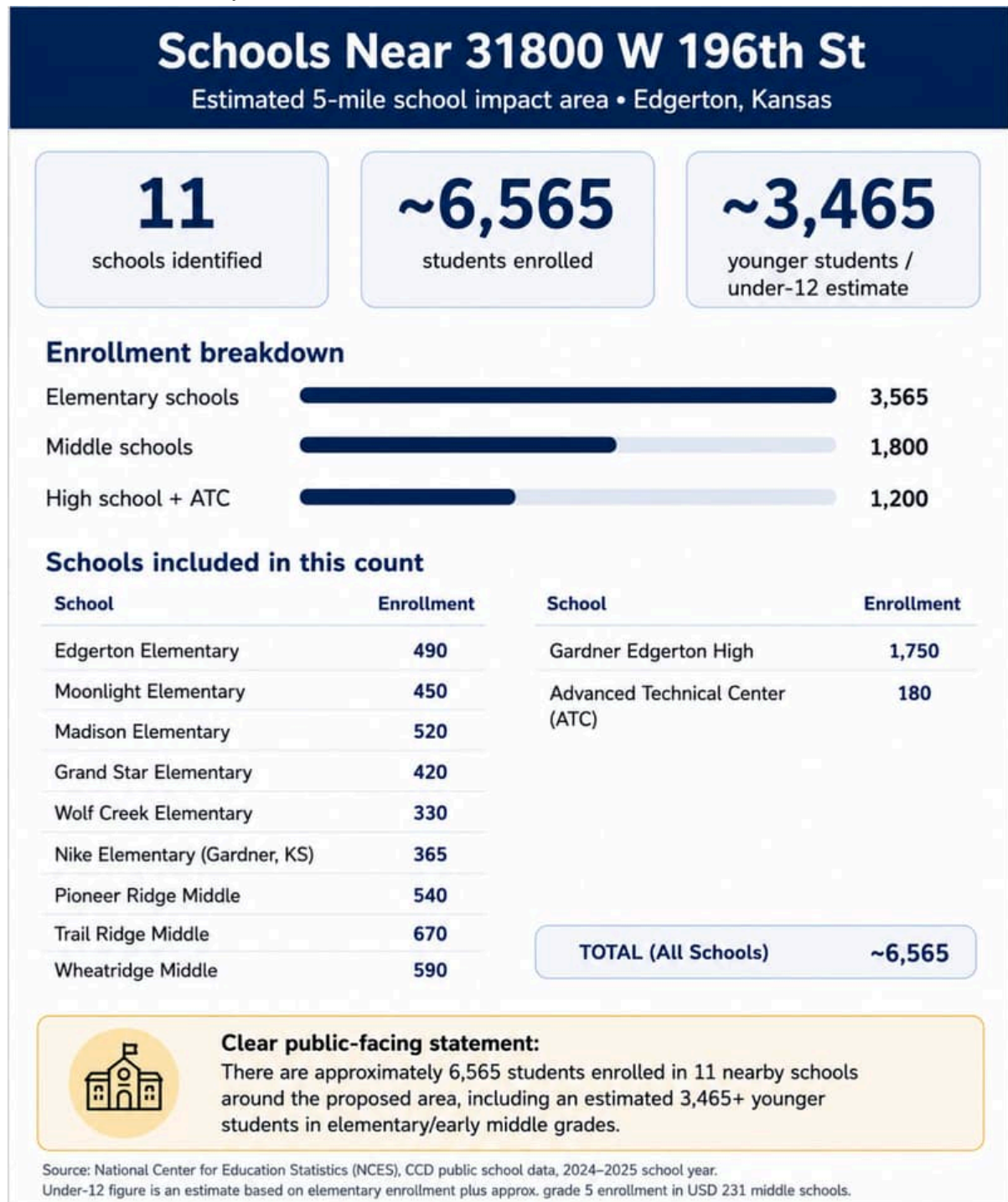

-Enormous amounts of energy used to power servers and cooling systems are creating "heat islands" with increased temperatures of up to 16 degrees F and measurable temperature increases extending as far as 6 miles from some facilities:

<https://www.wral.com/news/local/data-centers-north-carolina-heat-island-ai-climate-change-april-2026/?fbclid=IwY2xjawRtt-VleHRuA2FibQIxMABicmlkETFqzDVCQzVBTHlqYjRXeWNVc3J0YwZhcHBfaWQQMjlyMDM5MTc4ODI>

[wMDg5MgABHnNEt9FcKpO1QdZJN16Oc79yNnpcidRbb2SYIacu5uNIIb1SsoEEYCuc1z8_aem_SALtFaXTTpY0Bs5sPkoB3g](https://www.wmdg5mgabhnet9fcKpO1QdZJN16Oc79yNnpcidRbb2SYIacu5uNIIb1SsoEEYCuc1z8_aem_SALtFaXTTpY0Bs5sPkoB3g)

-Noise pollution is not adequately controlled by acoustic engineering and has massive health implications for those within miles of data centers, including headaches, vertigo, nausea, sleep disturbances, ear pain, and high blood pressure. Generators, which also run on a monthly basis for testing when not being used for additional power, can reach up to 105dB (as much as a jet engine) and are not held to time limits, provided the operator reports and logs the hours and the emergency:

<https://www.eesi.org/articles/view/communities-are-raising-noise-pollution-concernsabout-data-centers>

-Generators also emit harmful noxious fumes including nitrous oxide, fine particulate matter, and sulfur dioxide, all leading to severe health issues in nearby communities (such as increased asthma cases, respiratory infections, cardiovascular disease, and increased cancer risks). Lawsuits are being filed on account of these effects:

<https://www.selc.org/press-release/civil-rights-group-sues-xai-for-illegal-pollution-from-data-center-power-plant/>

<https://www.pecva.org/wp-content/uploads/Health-Impacts-Vantage-Data-Center-Report-2.pdf>

https://hsph.harvard.edu/news/analyzing-air-pollution-health-economic-risks-from-ai-data-centers/?fbclid=IwY2xjawRuAclleHRuA2FibQIxMABicmlkETFqeDVCQzVBTHlqYjRXeWNVc3J0YwZhcHBfaWQ_QMjlyMDM5MTc4ODIwMDg5MgABHum31WRDZeqybNJ3vanV4VMKycyxJxZEZXIxcDkicLU-McclHgGhqE7eG3W9_aem_0YAT3av5rZ2zctbf8lpKag

-"Closed loop" cooling systems are a myth:

<https://www.facebook.com/reel/1623493308964496>

As time goes on, it is becoming more and more apparent how devastating data centers are to human health. Take Virginia as an example, as they are now learning the hard way. Massive water consumption concentrates harmful PFOAs and other compounds in drinking water and "exacerbates local water insecurity," "persistent noise adversely affects nearby communities and local wildlife, prompting increased public concern," and air pollution is the most acute concern. Fossil-fueled power plants and diesel backup generators that power data centers emit hazardous pollutants such as nitrogen oxides and fine particulate matter, increasing rates of respiratory disease, cardiovascular conditions, and elevating cancer risk in nearby communities:

https://www.usnews.com/news/national-news/articles/2026-04-28/living-in-hell-data-center-neighbors-grapple-with-noise-air-pollution?fbclid=IwY2xjawRuA5tleHRuA2FibQIxMABicmlkETFqeDVCQzVBTHlqYjRXeWNVc3J0YwZhcHBfaWQ_QMjlyMDM5MTc4ODIwMDg5MgABHIKYCwIKQAspxFfv9N2ABDHRw2omCdDh7lqGCj6dANWXwvR1D_ZM3yoUT-E3T_aem_tIQjTzZp12qeO9L8Rn6Vvw

https://pmc.ncbi.nlm.nih.gov/articles/PMC12273412/?fbclid=IwY2xjawRuA7FleHRuA2FibQIxMABicmlkETFqeDVCQzVBTHlqYjRXeWNVc3J0YwZhcHBfaWQ_QMjlyMDM5MTc4ODIwMDg5MgABHuYGDpAXghhdL0GWdawuhIK_qPHyK6zfrjGmnhInbL33Krq9zGQtIthjFCGg_aem_3UXURM2hKHclxrzj9B3d0g

<https://www.frontiersin.org/journals/climate/articles/10.3389/fclim.2026.1648912/full>

This is only the tip of the iceberg, and only regarding these few issues. There may be a time and a place for such data centers, but the time is not until these risks can be truly mitigated to prevent harm to humans, the environment, and wildlife, and the place is certainly not in proximity to thriving, rural communities such as ours.

Thank you for the time and attention to the data presented here, and for understanding why so many people know a data center has no place in Edgerton or any of our surrounding communities.

Sincerely,
Kailey Dressler
kmesler@gmail.com

Re: Urgent concerns regarding proposed data center

From Kailey Dressler <kmesler@gmail.com>

Date Tue 5/12/2026 11:03 AM

To Dusti Callahan <dcallahan@edgertonks.org>



External (kmesler@gmail.com)



[Safe](#) [Spam](#) [Phish](#) [More...](#)

[External Sender]

Hi Dusti,

I would also like to add this information to the record, if possible:

There are numerous red flag in the literature provided on DAMAC's proposed Edgerton project website (<https://heartlanddatacenter.com/home/faqs?fbclid=IwVERFWARwErdleHRuA2F>). Intentionally vague and non-specific claims and promises with no data or evidence to back any of these statements can be found in their FAQs section.

For example, in the "What Neighbors Can Expect" section:

-Water: "Advanced cooling technology...ACROSS ALL OPERATING CONDITIONS."

-->The system may be closed loop for now (which is a myth to begin with), but leaves the door open for the possibility of water cooled later on. In March of this year, Amazon settled for \$20.5M in NE Oregon for contaminating their groundwater in exchange for no admission of guilt in the polluting-an admission in and of itself and simply a means to avoid more costly litigation. In Fayetteville, Georgia, residents noticed low water pressure last year. The utility discovered two unaccounted-for water connections at one of the nation's largest data center campuses. When the county utility investigated, officials discovered two industrial-scale water hookups feeding a data center campus located 20 miles south of downtown Atlanta. One water connection had been installed without the utility's knowledge, and the other was not linked to the company's account and therefore wasn't being billed. In total, the data center drained 30M gallons of water, all while residents were being told to stop watering lawns and otherwise conserve usage.

-Energy: "Dedicated power infrastructure..."

-->Are they creating their own power? Are they using gas turbines? Gas turbines emit smog forming pollution, fine particulate matter, and hazardous chemicals like formaldehyde that travel for miles, affecting multiple surrounding communities. There are over 6500 young children in a 5-mile radius of this proposed center, all at heightened risk of health complications from such pollution.

-->Diesel generators: though claimed to only be for backup power, monthly testing also occurs and operation is not held to time limits, provided the operator reports and logs the hours and the

emergency. Generators emit harmful noxious fumes including nitrous oxide, fine particulate matter, and sulfur dioxide, all leading to severe health issues in nearby communities (such as increased asthma cases, respiratory infections, cardiovascular disease, and increased cancer risks). Lawsuits are being filed on account of these effects in places like Mississippi.

-Noise: "Site-specific acoustic design, low noise equipment, and building setbacks engineered to meet or exceed local codes."

-->What is being proposed at this site, if this is "site specific?"

-->Noise pollution is already not adequately controlled by acoustic engineering and has massive health implications for those within miles of data centers, including headaches, vertigo, nausea, sleep disturbances, ear pain, and high blood pressure. As noted above, generators also run on a monthly basis for testing when not being used for additional power, can reach up to 105dB (as much as a jet engine) and are not held to time limits, provided the operator reports and logs the hours and the emergency.

-Lighting: "Security lighting oriented downward and contained within property boundaries to minimize nearby impact."

-->Does this look contained with minimal nearby impact?

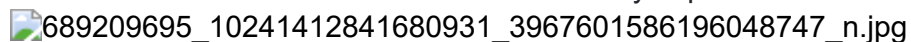

-Community: "Ongoing engagement with local organizations, transparent communication, and investment in Edgerton's long-term growth"

-->Transparent communication isn't vague statements as noted above, all of which can be refuted on their face by available information on existing data centers and the stark disconnect between empty promises and the harsh reality communities that are home to data centers are facing.

Moving on to Q&A:

Q: What will it be like living near the data center?

A: Data centers are among the quietest and least disruptive types of commercial development a community can host.

-->Is 105dB the quietest and least disruptive type of development many can think of?

-->Let's not forget the 24/7/365 persistent, low-frequency hum and buzz, audible for miles, driven by operation of cooling systems, HVAC units, and server fans, often exceeding noise regulation for nearby residents. These sounds have been well-documented to cause headaches, sleep disruption, and anxiety, amongst other chronic health conditions.

They produce no manufacturing byproducts,

-->Gasses and fumes from generators and gas turbines? Water pollutants from closed loop bleed and blow down? Concentration of PFOAs and other contaminants from depleted aquifers and water reserves?

require no heavy freight logistics, and operate with a small on-site workforce distributed across around-the-clock shifts.

-->IE, an open admission of the very few jobs this will actually create.

The result is a facility with minimal vehicle traffic, no large shift-change surges, and limited activity visible from surrounding properties.

-->aside from the light pollution seen from miles away.

Q: Will there be noise from the data center?

A: The facility is being designed with strict attention to noise management. DAMAC Digital's acoustic design process incorporates site-specific noise modeling developed in coordination with engineering specialists and local authorities, ensuring that sound levels at sensitive locations, particularly adjacent properties, are identified and addressed at the design stage rather than after construction.

On-site activity is relatively low volume. The primary sound sources are cooling equipment and backup generators. Cooling equipment noise is managed through a combination of acoustic enclosures, barriers, low-noise equipment selection, and strategic building and equipment orientation. Backup generators are designed to run only during actual

power outages and for brief periodic testing required by code. In practice, total generator operating time is expected to amount to only a few hours per year. These measures are designed to ensure that noise levels at the property boundary meet or exceed local code requirements.

-->It is well-documented that residents within several miles suffer consequences of ill-mitigated noise exposure, such as including headaches, vertigo, nausea, sleep disturbances, ear pain, and high blood pressure. Generators, which also run on a monthly basis for testing when not being used for additional power, can reach up to 105dB (as much as a jet engine) and are not held to time limits, provided the operator reports and logs the hours and the emergency (as previously mentioned). This is not "just a few hours per year."

Q: What about light pollution from the data center?

--> Please refer back to the photo from 5 miles away from the data center in rural TX.

Q: Should the community be concerned about air-quality impacts?

A: During normal day-to-day operations, the facility does not produce ongoing air emissions. The equipment inside the buildings is electronic and the cooling systems are mechanical. The only equipment with potential air-quality considerations is backup generators, which run only during power outages or brief periodic testing required by code. In practice, total generator operating time is expected to amount to only a few hours per year.

-->As previously mentioned, generators, which also run on a monthly basis for testing when not being used for additional power, are not held to time limits, provided the operator reports and logs the hours and the emergency (as previously mentioned). This is not "just a few hours per year." During this time, they will continue to emit harmful noxious fumes including nitrous oxide, fine particulate matter, and sulfur dioxide, all leading to severe health issues in nearby communities (such as increased asthma cases, respiratory infections, cardiovascular disease, and increased cancer risks). Lawsuits are being filed on account of these effects in places like Mississippi.

Q: How much water will this data center use?

A: Water efficiency is a central element of the facility's design. The facility cooling strategy is built around minimizing water consumption, with closed-loop technology as a core component. A closed-loop system is a fully sealed, recirculating system that transfers heat efficiently while minimizing water loss and avoiding contamination

-->Closed-loop systems rely on a cocktail of additives such as corrosion inhibitors, biocides, and antifreeze blends to keep water doing its job. They stop rust, starve microbes, and move heat off chips with high efficiency. But the protection comes with a trade-off. Because the same water loops again and again, anything that does not evaporate or break down simply piles up. Salts, metals, and treatment chemicals keep increasing in concentration with each recycling round and frequently reach concentrations that move well beyond established limits. Operators bleed a small fraction of water each month to keep these levels in check, a practice known as blow-down. Even a 2% monthly bleed sounds proactive, yet contaminants can still rise much faster than in open towers that take on fresh water continuously. Higher cycles push minerals out of solution, feed microbial slime, and shorten equipment life. The bigger worry sits outside the fence. When blow-down finally leaves the site, it can carry nitrite, glycol, and heavy metals at thousands of times the limits set for surface waters.

Real-World Red Flags

- Unplanned drain-downs – A single 500 m³ loop drained for repair can send over three tonnes of nitrite to the local plant.
- Valve leaks to storm drains – Glycol concentrations above 10% suffocate fish faster than raw sewage.
- Regulators are reacting – Regulators are now demanding lab analysis before loop water enters sewers, and thresholds are rapidly tightening, but action remains dangerously slow. **Data centers are critically under-equipped for real-time water quality monitoring, creating an imminent risk.**

A. The data center will be connected the public water supply

—>As previously mentioned, we should be worried about public water supply from both a pollution standpoint and the recent discoveries in GA with undisclosed water consumption.

Q: What will the project's overall environmental impact be?

A: Environmental responsibility is a priority in the design and operation of this facility. DAMAC digital is working to minimize its environmental footprint through efficient cooling technology, thoughtful site design, and adherence to internationally recognized effectiveness metrics for power, water, and carbon usage.

—>DAMAC, the company looking to swoop in and prey on our community's resources and in turn receive decades of tax abatements and incentives, claims they will minimize their environmental footprint without any concrete data or specifications on how this will be accomplished. How about an independent, city selected third party environmental impact assessment, fully funded by DAMAC, for an unbiased opinion on this topic?

Q: Will DAMAC Digital be a good neighbor?

—> With what is already known about data centers as well as the intentionally vague and misleading information present here, the answer to this question is a resounding NO

Thank you,
Kailey Dressler.

On Mon, May 11, 2026 at 3:04 PM Dusti Callahan <dcallahan@edgertonks.org> wrote:

Thank you!



Dusti Callahan • City Clerk
City of Edgerton, KS
404 E Nelson St. Edgerton, KS 66021
P: 913.893.6231
edgertonks.org

From: Kailey Dressler <kmesler@gmail.com>
Sent: Monday, May 11, 2026 3:01 PM
To: Dusti Callahan <dcallahan@edgertonks.org>
Subject: Re: Urgent concerns regarding proposed data center

[External Sender]

Hi Dusti,

Sure! Our address is 217 W Colleen Dr, Gardner, 66030.

Thank you!
Kailey

On Mon, May 11, 2026 at 8:05 AM Dusti Callahan <dcallahan@edgertonks.org> wrote:

Hello!

For your comment for May 12, 2026, we also need to get your address for the record. 😊

Thank you!

Dusti



Dusti Callahan • City Clerk
City of Edgerton, KS
404 E Nelson St. Edgerton, KS 66021
P: 913.893.6231
edgertonks.org

From: Kailey Dressler <kmesler@gmail.com>
Sent: Monday, May 11, 2026 7:22 AM
To: City Clerk Distribution List <cityclerk@edgertonks.org>
Subject: Urgent concerns regarding proposed data center

[External Sender]

To Whom It May Concern,

All of a sudden, data centers are knocking at the doors of numerous communities across the country, and more recently, in Johnson County and surrounding neighborhoods. While they may look enticing at first pass with their promises of revenue and "mitigated" risk, it has more recently come to light that the data centers of today are not like anything we have seen before, and promises of risk mitigation from developers and data center companies are not only holding empty, but are completely false:

- EMF radiation is a huge, under recognized and extremely hazardous consequence of data centers, particularly for children. "Non-ionizing EMFs have been linked by credible peer-reviewed published scientific studies to childhood leukemia, central nervous system tumors, brain cancer, breast cancer, Alzheimer's disease, cognitive dysfunction, miscarriage, ADHD, obesity, asthma, oxidative stress, free radical formation, and DNA damage. Hundreds of scientists have called for risk mitigation measures to reduce public exposure to non-ionizing EMFs."

https://ehsciences.org/data-centers-increase-electromagnetic-fields-emf-exposure/?fbclid=IwY2xjawRuBCpleHRuA2FibQlxMABicmlkETFqeDVCQzVBTHlqYjRxeWNVc3J0YwZhcHBfaWQQMjlyMDM5MTc4ODlwMDg5MgABHgeOG8-JYZUP8Cz9PEhdKO4yDMVs-FHbSrcK9XBUAP3N8CAEx9Z_XDY1So0T_aem_QZla_moEa7a7-t8SEJ6AJg

While these problems affect everyone, the young and elderly are particularly susceptible to negative health impacts. There are over 6,500 students in multiple communities within a 5 mile radius of this proposed data center, with over half of those in elementary school and severely susceptible to negative health outcomes directly related to this center.

Schools Near 31800 W 196th St

Estimated 5-mile school impact area • Edgerton, Kansas

11

schools identified

~6,565

students enrolled

~3,465

younger students /
under-12 estimate

Enrollment breakdown

Elementary schools	<div style="width: 55%;"></div>	3,565
Middle schools	<div style="width: 28%;"></div>	1,800
High school + ATC	<div style="width: 17%;"></div>	1,200

Schools included in this count

School	Enrollment	School	Enrollment
Edgerton Elementary	490	Gardner Edgerton High	1,750
Moonlight Elementary	450	Advanced Technical Center (ATC)	180
Madison Elementary	520		
Grand Star Elementary	420		
Wolf Creek Elementary	330		
Nike Elementary (Gardner, KS)	365		
Pioneer Ridge Middle	540		
Trail Ridge Middle	670		
Wheatridge Middle	590		
		TOTAL (All Schools)	~6,565



Clear public-facing statement:

There are approximately 6,565 students enrolled in 11 nearby schools around the proposed area, including an estimated 3,465+ younger students in elementary/early middle grades.

Source: National Center for Education Statistics (NCES), CCD public school data, 2024–2025 school year.
Under-12 figure is an estimate based on elementary enrollment plus approx. grade 5 enrollment in USD 231 middle schools.

-Enormous amounts of energy used to power servers and cooling systems are creating "heat islands" with increased temperatures of up to 16 degrees F and measurable temperature increases extending as far as 6 miles from some facilities:

https://www.wral.com/news/local/data-centers-north-carolina-heat-island-ai-climate-change-april-2026/?fbclid=IwY2xjawRtt-VleHRuA2F1bQlxMABicmlkETFqeDVCQzVBTHlqYjRXeWNVc3J0YwZhcHBfaWQQMjlyMDM5MTc4ODlwMDg5MgABHnNEt9FcKpO1QdZJNl6Oc79yNnpqidRbb2SYlacu5uNlIb1SsoEEYCuc1z8_aem_SALtFaXTTpY0Bs5sPkoB3g

-Noise pollution is not adequately controlled by acoustic engineering and has massive health implications for those within miles of data centers, including headaches, vertigo, nausea, sleep disturbances, ear pain, and high blood pressure. Generators, which also run on a monthly basis for testing when not being used for additional power, can reach up to 105dB (as much as a jet engine) and are not held to time limits, provided the operator reports and logs the hours and the emergency:

<https://www.eesi.org/articles/view/communities-are-raising-noise-pollution-concernsabout-data-centers>

-Generators also emit harmful noxious fumes including nitrous oxide, fine particulate matter, and sulfur dioxide, all leading to severe health issues in nearby communities (such as increased asthma

cases, respiratory infections, cardiovascular disease, and increased cancer risks). Lawsuits are being filed on account of these effects:

<https://www.selc.org/press-release/civil-rights-group-sues-xai-for-illegal-pollution-from-data-center-power-plant/>

<https://www.pecva.org/wp-content/uploads/Health-Impacts-Vantage-Data-Center-Report-2.pdf>

[https://hsph.harvard.edu/news/analyzing-air-pollution-health-economic-risks-from-ai-data-centers/?](https://hsph.harvard.edu/news/analyzing-air-pollution-health-economic-risks-from-ai-data-centers/?fbclid=IwY2xjawRuAclleHRuA2FibQIxMABicmlkETFqeDVCQzVBTHlqYjRXeWNVc3J0YwZhcHBfaWQ)

[fbclid=IwY2xjawRuAclleHRuA2FibQIxMABicmlkETFqeDVCQzVBTHlqYjRXeWNVc3J0YwZhcHBfaWQ](https://hsph.harvard.edu/news/analyzing-air-pollution-health-economic-risks-from-ai-data-centers/?fbclid=IwY2xjawRuAclleHRuA2FibQIxMABicmlkETFqeDVCQzVBTHlqYjRXeWNVc3J0YwZhcHBfaWQ)
[QMjlyMDM5MTc4ODlwMDg5MgABHum31WRDZeqvbNJ3vanV4VMKycyxJxZEZXlxcDkicIU-McclHgGhqE7eG3W9_aem_0YAT3av5rZ2zctbf8lpKag](https://hsph.harvard.edu/news/analyzing-air-pollution-health-economic-risks-from-ai-data-centers/?fbclid=IwY2xjawRuAclleHRuA2FibQIxMABicmlkETFqeDVCQzVBTHlqYjRXeWNVc3J0YwZhcHBfaWQ)

- "Closed loop" cooling systems are a myth:

<https://www.facebook.com/reel/1623493308964496>

As time goes on, it is becoming more and more apparent how devastating data centers are to human health. Take Virginia as an example, as they are now learning the hard way. Massive water consumption concentrates harmful PFOAs and other compounds in drinking water and "exacerbates local water insecurity," "persistent noise adversely affects nearby communities and local wildlife, prompting increased public concern," and air pollution is the most acute concern. Fossil-fueled power plants and diesel backup generators that power data centers emit hazardous pollutants such as nitrogen oxides and fine particulate matter, increasing rates of respiratory disease, cardiovascular conditions, and elevating cancer risk in nearby communities:

[https://www.usnews.com/news/national-news/articles/2026-04-28/living-in-hell-data-center-neighbors-grapple-with-noise-air-pollution?](https://www.usnews.com/news/national-news/articles/2026-04-28/living-in-hell-data-center-neighbors-grapple-with-noise-air-pollution?fbclid=IwY2xjawRuA5tleHRuA2FibQIxMABicmlkETFqeDVCQzVBTHlqYjRXeWNVc3J0YwZhcHBfaWQ)

[fbclid=IwY2xjawRuA5tleHRuA2FibQIxMABicmlkETFqeDVCQzVBTHlqYjRXeWNVc3J0YwZhcHBfaWQ](https://www.usnews.com/news/national-news/articles/2026-04-28/living-in-hell-data-center-neighbors-grapple-with-noise-air-pollution?fbclid=IwY2xjawRuA5tleHRuA2FibQIxMABicmlkETFqeDVCQzVBTHlqYjRXeWNVc3J0YwZhcHBfaWQ)
[QMjlyMDM5MTc4ODlwMDg5MgABHIKYCwIKQAspxFfv9N2ABDHRw2omCdDh7lqGCj6dANWXwwR1DZM3yoUT-E3T_aem_tIQjTzZp12qeO9L8Rn6Vvw](https://www.usnews.com/news/national-news/articles/2026-04-28/living-in-hell-data-center-neighbors-grapple-with-noise-air-pollution?fbclid=IwY2xjawRuA5tleHRuA2FibQIxMABicmlkETFqeDVCQzVBTHlqYjRXeWNVc3J0YwZhcHBfaWQ)

[https://pmc.ncbi.nlm.nih.gov/articles/PMC12273412/?](https://pmc.ncbi.nlm.nih.gov/articles/PMC12273412/?fbclid=IwY2xjawRuA7FleHRuA2FibQIxMABicmlkETFqeDVCQzVBTHlqYjRXeWNVc3J0YwZhcHBfaWQ)

[fbclid=IwY2xjawRuA7FleHRuA2FibQIxMABicmlkETFqeDVCQzVBTHlqYjRXeWNVc3J0YwZhcHBfaWQ](https://pmc.ncbi.nlm.nih.gov/articles/PMC12273412/?fbclid=IwY2xjawRuA7FleHRuA2FibQIxMABicmlkETFqeDVCQzVBTHlqYjRXeWNVc3J0YwZhcHBfaWQ)
[QMjlyMDM5MTc4ODlwMDg5MgABHuYGDpAXghhdL0GWdawuhIK_qPHyK6zfrjGmnhInbL33Krq9zGQtlthjfCGg_aem_3UXURM2hKHclxrzj9B3d0g](https://pmc.ncbi.nlm.nih.gov/articles/PMC12273412/?fbclid=IwY2xjawRuA7FleHRuA2FibQIxMABicmlkETFqeDVCQzVBTHlqYjRXeWNVc3J0YwZhcHBfaWQ)

<https://www.frontiersin.org/journals/climate/articles/10.3389/fclim.2026.1648912/full>

This is only the tip of the iceberg, and only regarding these few issues. There may be a time and a place for such data centers, but the time is not until these risks can be truly mitigated to prevent harm to humans, the environment, and wildlife, and the place is certainly not in proximity to thriving, rural communities such as ours.

Thank you for the time and attention to the data presented here, and for understanding why so many people know a data center has no place in Edgerton or any of our surrounding communities.

Sincerely,
Kailey Dressler
kmesler@gmail.com

Letter of Support | DAMAC Digital

From Kara Lowe <kara@kctechcouncil.com>

Date Tue 5/12/2026 12:56 PM

To City Clerk Distribution List <cityclerk@edgertonks.org>

Cc Christine Murray <christine@kctechcouncil.com>; Erin Christensen <erin@kctechcouncil.com>

 1 attachment (61 KB)

DAMAC Support Letter _ KC Tech Council.pdf;



Caution: External (kara@kctechcouncil.com)

First-Time Sender [Details](#)



[Safe](#) [Spam](#) [Phish](#) [More...](#)

[External Sender]

Good afternoon, Ms. Callahan!

Please find attached a letter of support for the proposed DAMAC Digital project. We appreciate your consideration on behalf of Kansas City's tech industry, and are glad to help serve as a resource as the community considers this project.

Thank you!
Kara

KARA LOWE

President & Chief Executive Officer | [KC Tech Council](#)

NEW ADDRESS STARTING 1.1.26:

710 Central, Ste. 200 | Kansas City, MO 64105



[Book time to meet with me](#)



May 12, 2026

Ms. Dusti Callahan, City Clerk
City of Edgerton
404 East Nelson Street
Edgerton, Kansas

RE: Planning Commission Meeting – May 12, 2026

DAMAC Digital

Items: PP2026-0001 and FSP2026-0002

Dear Commission Members,

My name is Kara Lowe, and I serve as President & CEO of the KC Tech Council. As the voice of the region's tech industry, with more than 5,000 tech companies and a workforce where 1 in 10 Kansas Citians are employed in tech, our mission is to advance the growth and competitiveness of the Kansas City technology ecosystem.

The proposed investment by DAMAC Digital in Edgerton represents a significant and strategic opportunity for both the local community and the broader Kansas City region. As demand for digital infrastructure accelerates, driven by cloud computing, artificial intelligence, and data-intensive industries, projects like this position our region to compete on a global stage for innovation, talent, and capital investment.

Data centers are foundational infrastructure for today's economy. They enable not only everyday connectivity, but also power critical sectors including healthcare, financial services, education, advanced manufacturing, and national security. Beyond their technical importance, projects like this create meaningful economic impact—supporting high-quality jobs, driving construction and engineering activity, and strengthening the long-term tax base for communities like Edgerton.

The KC Tech Council is proud to support investments that reinforce our region's position as a hub for digital infrastructure and innovation. We appreciate the City of Edgerton's leadership and thoughtful consideration of this opportunity, and we look forward to continued collaboration in advancing projects that drive sustainable economic growth.

Respectfully,

Kara Lowe
President & CEO
Kansas City Tech Council



May 12, 2026

Dear Edgerton Planning Commission,

I'm writing in support of the Heartland Data Center project, proposed for 31800 W. 196th St. within Kansas City Logistics Park, where an existing 400,000-square-foot warehouse will be converted into a best-in-class data center.

If this project is approved, Edgerton will house a critical part of the infrastructure that stores and processes the data behind virtually everything we do online – from streaming video to managing bank accounts and from GPS navigation to maintaining electronic health records. More importantly, Edgerton will gain a wonderful new neighbor with a vision of making the City and Johnson County a better place to live and work.

Heartland Data Center is committed to building a long-term, positive relationship with the community. That commitment starts with how the facility is designed, with careful attention to noise, lighting, traffic, and environmental impact, and extends to how the data center will operate as a member of the Edgerton community.

Much misinformation has been shared about data centers. But data centers are among the quietest and least disruptive types of commercial development a community can host.

The project will have a positive economic impact almost immediately. The construction phase alone requires a broad range of skilled trades – from civil and structural engineers to electricians and HVAC technicians to plumbers and pipefitters to ironworkers, carpenters, and more. This diversity of trades means the generation of hundreds of local employment opportunities across a wide range of skill levels and certifications.

Once operational, Heartland Data Center will employ full-time technical and operations staff, with combined annual payroll of approximately \$2.4 million. These are highly skilled, well-paying roles in areas such as engineering, network operations, security, and facilities management, providing considerable economic and employment opportunities for individuals within the community.

The intent is to hire from the local and regional workforce for both construction and permanent operations roles. Many data center positions require trade certifications or six to 12 months of specialized training, rather than a four-year degree. Partnerships with area educational institutions and workforce development organizations – such as Gardner-Edgerton School District USD 231 and Johnson County Community College – are being explored to help connect residents with the skills and training they need for careers in data center construction and operations.

AMERICA'S #1 POSITIONING AD AGENCY

4715 Whipple Ave NW, Canton, OH 44718
330.492.5500 innismaggiore.com



Other economic benefits include significant sales tax and property tax revenue to support local infrastructure — like storm water systems and streets — and school districts; direct spending with local businesses and contractors during construction and ongoing operations; and the potential to attract additional technology-sector investment to the community.

There also will be significant indirect and induced economic activity through local procurement of goods and services, contractor relationships, and employee spending locally. Large infrastructure investments of this kind have historically been associated with stable or increased property values in surrounding areas.

Heartland Data Center will engage with local organizations and nonprofits, contribute employees' time and resources, and maintain open, transparent communication with residents throughout development ... and beyond. The goal is not simply to renovate an existing facility in Edgerton, but to be a meaningful contributor to the community's long-term well-being.

As you continue to interact with the Heartland Data Center team, it's easy to see that its members are truly committed to becoming important contributors to the Edgerton community. A yes vote today to push this project to the next step is a yes vote to making Edgerton a stronger, more vibrant community tomorrow.

Thank you for your consideration,

A handwritten signature in blue ink that reads "Mark Vandegrift".

Mark Vandegrift
President & CEO
Innis Maggiore Group, Inc.
(Consultant to Project)

AMERICA'S #1 POSITIONING AD AGENCY

4715 Whipple Ave NW, Canton, OH 44718
330.492.5500 innismaggiore.com

Subject for the Planning Commission Meeting 5/12

From Pam Sill <pam_sill@yahoo.com>

Date Fri 5/8/2026 11:58 AM

To City Clerk Distribution List <cityclerk@edgertonks.org>



Caution: External (pam_sill@yahoo.com)

First-Time Sender [Details](#)



[Safe](#) [Spam](#) [Phish](#) [More...](#)

[External Sender]

We have been told to send emails to the city clerk with topics about the Data Centers that we would like addressed at the meeting on 5/12. Please give this to the committee members to address during the meeting. This came from the Facebook page No Data Centers from a Gardner Citizen that contacted the Corp of Engineers for Hillsdale Lake about water concerns when Beale approached Gardner for a Data Center.

“During gathering information for Gardner I called the Army corp of engineers at Hillsdale to get some information about the water. When he called me back he told me they had a study going that could have 3 outcomes..

- 1)a new waste water plant in Spring Hill
- 2) a region wastewater outflow outside the water shed area
- 3)or upgrade ones we have.

He gave me the project managers email and I have one that I was going to send when Beale pulled out.

I don't know if it will help Edgerton. It's good to know that they are involved and worries about it like we are. He also said that the stake holders have been involved. Not sure if Edgerton was involved. If Edgerton is involved who pays for these options?”

Pam Sill

VOTE NO DATA CENTER

From Sarah Grady <sarahegrady@hotmail.com>

Date Tue 5/12/2026 2:28 PM

To City Clerk Distribution List <cityclerk@edgertonks.org>



Caution: External (sarahegrady@hotmail.com)

First-Time Sender [Details](#)



[Safe](#) [Spam](#) [Phish](#) [More...](#)

[External Sender]

Hello:

I am a Spring Hill resident and AGAINST a data center in this area. The reason this is of concern to me is because Spring Hill is in the Hillsdale Lake watershed. I am AGAINST the pollution of our drinking water. A data center in Gardner would pollute the Hillsdale Lake watershed. I have five young children and in no way should we have to worry about the health of our children and the safety of our children's drinking water. If a data center goes in at this location, it will affect over 50,000 people's water. Please vote NO against a data center. Do not sell us out.

Thank you,

Sarah Grady
Spring Hill Resident
Sent from my iPhone

FW: Data Center

From Donald Roberts <mayor@edgertonks.org>
Date Wed 5/6/2026 3:30 PM
To City Clerk Distribution List <cityclerk@edgertonks.org>



Internal (mayor@edgertonks.org)



[Safe](#) [Spam](#) [Phish](#) [More...](#)

From: Stacy Brawley <kyshymomom@gmail.com>
Sent: Wednesday, May 6, 2026 3:01 PM
To: Donald Roberts <mayor@edgertonks.org>
Subject: Data Center

[External Sender]

Dear Donald Robert's,

I am writing to express my strong opposition to the proposed data center in our community. As a concerned citizen, I believe the significant health and environmental risks associated with this project cannot be ignored.

I urge you to prioritize the well-being of your constituents and vote against the development of data centers in our area. Please be advised that my support in future elections will be contingent upon your decision on this matter.

Thank you for your time and for considering the concerns of the citizens you represent.

Sincerely,

Stacy Brawley

Say NO to the Data Center

From Sydnee Gibson <sydneegibson615@gmail.com>

Date Thu 5/7/2026 12:02 PM

To Donald Roberts <mayor@edgertonks.org>; Clay Longanecker <clonganecker@edgertonks.org>; Josh Lewis <jlewis@edgertonks.org>; rconcus@edgertonks.org <rconcus@edgertonks.org>; Bill Malloy <Bmalloy@edgertonks.org>; Deb Lebakken <dlebakken@edgertonks.org>; Community Development <CommunityDevelopment@edgertonks.org>; info@edgertonks.org <info@edgertonks.org>; City Clerk Distribution List <cityclerk@edgertonks.org>



Caution: External (sydneegibson615@gmail.com)

First-Time Sender [Details](#)



[Safe](#) [Spam](#) [Phish](#) [More...](#)

[External Sender]

All,

My name is Sydnee Gibson and I live at 433 W Hawthorn St. in Gardner, however the city of Edgerton is walking distance away. I know they are putting a limit on comments from the public at your next meeting, so here is what I would say if I was there:

I urge you to say NO to the data center.

Look at what is happening in Desoto, and see what happened in Gardner when incentives were off the table. These large companies don't care about the citizens of the town they are taking over, they only care about money. Please don't be the same way. Your citizens DON'T want this. Your citizen's health matters more. Their quality of life matters more.

Think of your health and try to put a price on it. How much are you willing to risk? Think of your children. How much is their health worth to you? You not only have their lives to think about but the entire city of Edgerton and surrounding areas to think of.

I understand that in order for technology to grow and expand, data centers are necessary. But not here. Tell them to leave Edgerton alone!

I know this is a big decision for you all to make, I just hope that you will not take it lightly. That you consider the voices of your neighbors, your colleagues, strangers of the people from neighboring towns, and you are all able to sleep at night knowing it was the right one...

We are praying for you all, and praying for the city of Edgerton. Thank you,

Sydnee Gibson

Re: Public Comment May 12 2026

From Dusti Callahan <dcallahan@edgertonks.org>

Date Thu 5/7/2026 12:51 PM

To Dusti Callahan <dcallahan@edgertonks.org>



Internal (dcallahan@edgertonks.org)



[Safe](#) [Spam](#) [Phish](#) [More...](#)

We will be attending the meeting but I want to have our voice on public record.

Myself and my family are strongly opposed to the prospect of a data center coming into our small town. These places do not bring jobs for us, they will bring in outside people instead. I know their promises sound pleasant, but we have learned that promises are often not kept!

They will drain our resources and we, the people in this community will be the ones paying the price with increased utility prices, possibly water conservation just so they can keep running.

They are known to create extra heat, noise, and produce high carbon emissions that will impact us all.

High carbon emissions not only hurt us, but also the animals in the area because they actually change the climate, leading to food shortages, and health issues for all of us, man and animals. And these carbon emissions will only expand over time. These cause respiratory illnesses, cardiovascular disease, and increased cancer risks for everyone!

E-waste is terrible. Data centers are major contributors to global e-waste, which reached 68,343,301 tons in 2022 alone! This includes servers, storage drives, and power units, with rapid upgrades driven by AI shortening lifecycles to 3–5 years. And a lot will wind up in landfills. Things like mercury and cadmium! Do you want to pass that on to your grandchildren! Great grandchildren! Because if they are still here, they will be the ones cleaning up the mess!

I'm aware that they can potentially create a tax boost, after their tax incentives have been met, that would be years down the line, meanwhile, as i have said, our wonderful small town would be the ones paying the price. (Many companies that were given tax incentives, as soon as they were met have left!)

Many do not know that this company DMAC digital isn't an American company. They are from Dubai. Do we really think that they are considering the welfare of the people who are not their own! DAMAC has faced repeated criticism for poor-quality construction and failure to deliver projects on time, particularly during the 2008 financial crisis. These issues have eroded trust among among investors and buyers, many who suffered from financial losses as a result, according to an article in July of 2025.

Please, do not allow this to happen to our wonderful town. I would really not like to look back 50 years and say these are the people who destroyed what was a beautiful town!

Sincerely and for the record,
Tina and Roger Cain

FW: Urgent Concern Regarding Proposed Data Center

From Donald Roberts <mayor@edgertonks.org>
Date Fri 5/8/2026 5:22 PM
To City Clerk Distribution List <cityclerk@edgertonks.org>

 Internal (mayor@edgertonks.org)

 imagine IT

[Safe](#) [Spam](#) [Phish](#) [More...](#)

From: Hi <wendymbeers@aol.com>
Sent: Friday, May 8, 2026 2:16 PM
To: Donald Roberts <mayor@edgertonks.org>
Subject: Urgent Concern Regarding Proposed Data Center

[External Sender]

Dear Mayor Donald Roberts,

Hi, my name is Wendy Beers. I usually am not involved in politics, but I am truly fearful about the health of the people in Gardner and Edgerton. As a resident of Gardner for 18 years, I am writing to formally express my strong opposition to the proposed data center project possibly coming to Edgerton, Kansas.

PLEASE take time to watch this very short video from Senator Hawley asking great questions and concerns!

If you truly care about your city and the people around you, you will watch this short video and say No to the data center. Shut it down!

<https://www.facebook.com/share/v/1H4DwS7hF2/>

This decision has a potential to cause great harm and impact your city negatively. There's already been over 10,000 studies that they do cause harm. If harm comes to your citizens and the neighboring cities then there can be risk of your city getting lawsuits, or better yet you have to pay the cost to sue the data center for their negligence. Who is going to enforce that they are holding to what they are saying? What integrity, transparency, and character does your city represent if you sell out, when Spring hill and Gardner said no.

If you choose to go forward with this project it will give the city of Edgerton a very bad name. People do not want data centers in this area! People will definitely not want to move to this area. Housing prices will go down, it will be very bad for this area.

Empirical research is urgently needed to inform policy. Little is known about long-term health outcomes in data center host communities. Interdisciplinary studies should quantify pollution exposures (air, water, noise) and track associated health effects. (PMC PubMed Central 2025 May 27)

Please spend a good amount of time truly researching and studying some of the health risks especially the acoustic health risks before making any decisions. A simple Google search will show that there is definitely a concern for health risks. This technology is too new to be gambling with the lives of the precious people in this city! Many other surrounding cities are rejecting the data centers, so why put the people of Gardner at risk.

My opposition to the data center coming to Gardner Kansas is very personal for me. I've been battling health issues for many years and I am very concerned what this could do to my health. I am not physically able to attend a meeting so I hope this email will be taken seriously. This is new technology and it has not been well studied yet. It puts the citizens at great risk for not knowing the potential health outcomes.

These facilities often increase local respiratory and cardiovascular issues, with 2030 projections suggesting hundreds of thousands of asthma cases and over 1,000 premature deaths annually due to emissions.

While I understand the need for digital infrastructure, this project poses unacceptable risks to our community's quality of life and resources. My concerns are focused on these main areas:

1. Noise Pollution: HVAC systems and generators can exceed 90 decibels, causing constant noise that can interfere with sleep and health, similar to a "consistent hum" or "earsore".
2. Water Usage: Mid-sized facilities can use 300,000 gallons of water a day, with large ones taking up to 5 million gallons, often in water-stressed areas
3. Tax Incentives: Data centers often seek 20-year, 90% tax abatements, meaning they bring in little tax revenue to fund local schools or infrastructure.
4. Low Employment: A review of 1,200+ U.S. data centers found that even the largest often employ fewer than 150 permanent workers.

5. Power Grid Load: Data centers can inflate regional energy bills for residents, with some studies estimating up to 25% increases in certain markets.

I urge you to vote against the rezoning, tax incentives, or site plan approval for this project. This community deserves responsible development that prioritizes the health and wellbeing of residents over high-tech industrial expansion.

Thank you for your time and for representing our interests. Please respond back to me so that I know that you read this email. Please let me know how this can be stopped. I hope my voice will be heard and taken seriously.

Here is some more information about the health risk associated to data centers.

1. Empirical research is urgently needed to inform policy. Little is known about long-term health outcomes in data center host communities. Interdisciplinary studies should quantify pollution exposures (Ms.air, water, noise) and track associated health effects.

https://pmc.ncbi.nlm.nih.gov/articles/PMC12273412/?fbclid=IwDGRjcARI6u1jbGNrBEjqr2V4dG4DYWVtAjExAHNydGMGYXBwX2IkDDM1MDY4NTUzMTcyOAABHkPiw_XzjmT68vDLk2-xsqH6LyHACaE0PUyGvKSin4vMnmznHqNq5LCAdygi_aem_w5bQ_8EGg4-c4_BcTOTOig

2. Data Centers behaving like acoustic weapons study

https://m.youtube.com/watch?v=_bP80DEAbuo&fbclid=IwVERDUARI6MtleHRuA2FibQIxMABzcnRjBmFwcF9pZAwzNTA2ODU1MzE3MjgAAR4BSI7HsV1aUbkYpEMuH_fFrG0hiPVkPjvcTOSo7aLTyvyzCXliCgBu-kzhcpA_aem_c-7u9kaQ0W3w5I2A7k9YOA

3. Harvard

https://hsph.harvard.edu/news/analyzing-air-pollution-health-economic-risks-from-ai-data-centers/?fbclid=IwDGRjcARI6aFjbGNrBEjpm2V4dG4DYWVtAjExAHNydGMGYXBwX2IkDDM1MDY4NTUzMTcyOAABHkQw0GabepkBVfZpkCMPa3hyQ2eT29ilVYpumwQd_ybWupFHGBwwSjuFY9IA_aem_gkkYkQQv1lppb0yaE7aIEQ

Sincerely,

Wendy Beers

636 East Acorn St.

Gardner,Ks. 66030
913-256-9474

Urgent Noise Concern Regarding Proposed Data Center

From Hi <wendymbeers@aol.com>

Date Sat 5/9/2026 6:36 PM

To City Clerk Distribution List <cityclerk@edgertonks.org>



External (wendymbeers@aol.com)



[Safe](#) [Spam](#) [Phish](#) [More...](#)

[External Sender]

Dear City Clerk,

I'm very thankful that Edgerton have council members who want to hear from us and are thinking about the safety and concerns for the citizens and surrounding neighbors. Please think about the serious info below and talk with the council members.

Please listen to what these data centers sound like here.

1. Man speaks out about the sound of the data center" he can't sell his home now.

<https://share.google/M9qi83shfdA7FYe6W>

2. <https://www.facebook.com/share/v/1aW9exZoHr/>

3. <https://www.facebook.com/share/r/1Jdtdz94PA/>

Harmful affects to cattle, chickens, our food sources

Sound travels. If neighbors have a small gathering and are talking even softly you can hear the rumbling sound of the neighbors talking outside. This would be our whole city and surrounding cities continuously with a rumbling noise.

Will there be studies done to see how far the sound echos or travels from the location of the data center. Even if they are saying it's at talking level decibels we don't hear neighbors talking 24/7. We won't have peaceful nights because the sound would be continuous just like in these videos.

Trying to sell a home with a continuous sound going through the city will be very difficult.

Who will enforce the sound and EMF regulations of the facility? What will the EMF levels be? Will that be a cancer or neurological risk?

Please study the physiological effects of sub-sonic frequencies not only on the citizens but farm animals, wild life.

Please consider going to a data center and staying by it for a long periods of time even while you're trying to sleep to see if the humming sound that would be continuous even if it's at low decibels what that would be like before you make your decision. Your choice changes everything for everyone in the surrounding area. Sound would be continuous that's what you would be doing to the whole city and surrounding areas.

Please share this opportunity to talk with the council members about the sound health risks.

PLEASE WATCH the video of someone who has done studies on the health risks.

https://youtu.be/_bP80DEAbuo?si=oeSbKXRnQHQu21mC

Thank you,
Wendy Beers

[Sent from AOL on Android](#)

----- Forwarded Message -----

From: "Hi" <wendymbears@aol.com>

To: "Cityclerk@edgertonks.org" <Cityclerk@edgertonks.org>

Sent: Fri, May 8, 2026 at 2:58 PM

Subject: Urgent Concern Regarding Proposed Data Center

Dear City Clerk,

Hi, my name is Wendy Beers. I usually am not involved in politics, but I am truly fearful about the health of the people in Gardner and Edgerton. As a resident of Gardner for 18 years, I am writing to formally express my strong opposition to the proposed data center project possibly coming to Edgerton, Kansas.

PLEASE take time to watch this very short video from Senator Hawley asking great questions and concerns!

If you truly care about your city and the people around you, you will watch this short video and say No to the data center. Shut it down!

<https://www.facebook.com/share/v/1H4DwS7hF2/>

This decision has a potential to cause great harm and impact your city negatively. There's already been over 10,000 studies that they do cause harm. If harm comes to your citizens and the neighboring cities then there can be risk of your city getting lawsuits, or better yet you have to pay the cost to sue the data center for their negligence. Who is going to enforce that they are holding to what they are saying? What integrity, transparency, and character does your city represent if you sell out, when Spring Hill and Gardner said no.

If you choose to go forward with this project it will give the city of Edgerton a very bad name. People do not want data centers in this area! People will definitely not want to move to this area. It will make our houses very difficult to sell.

Empirical research is urgently needed to inform policy. Little is known about long-term health outcomes in data center host communities. Interdisciplinary studies should quantify pollution exposures (air, water, noise) and track associated health effects. (PMC pubMed Central 2025 May 27)

Please spend a good amount of time truly researching and studying some of the health risks especially the acoustic health risks before making any decisions. A simple Google search will show that there is definitely a concern for health risks. This technology is too new to be gambling with the lives of the precious people in this city! Many other surrounding cities are rejecting the data centers, so why put the people of Gardner at risk.

My opposition to the data center coming to Gardner Kansas is very personal for me. I've been battling health issues for many years and I am very concerned what this could do to my health. I am not physically able to attend a meeting so I hope this email will be taken seriously. This is new technology and it has not been well studied yet. It puts the citizens at great risk for not knowing the potential health outcomes.

These facilities often increase local respiratory and cardiovascular issues, with 2030 projections suggesting hundreds of thousands of asthma cases and over 1,000 premature deaths annually due to emissions.

While I understand the need for digital infrastructure, this project poses unacceptable risks to our community's quality of life and resources. My concerns are focused on these main areas:

1. Noise Pollution: HVAC systems and generators can exceed 90 decibels, causing constant noise that can interfere with sleep and health, similar to a "consistent hum" or "earsore".
2. Water Usage: Mid-sized facilities can use 300,000 gallons of water a day, with large ones taking up to 5 million gallons, often in water-stressed areas
3. Tax Incentives: Data centers often seek 20-year, 90% tax abatements, meaning they bring in little tax revenue to fund local schools or infrastructure.
4. Low Employment: A review of 1,200+ U.S. data centers found that even the largest often employ fewer than 150 permanent workers.

5. Power Grid Load: Data centers can inflate regional energy bills for residents, with some studies estimating up to 25% increases in certain markets.

I urge you to vote against the rezoning, tax incentives, or site plan approval for this project. This community deserves responsible development that prioritizes the health and wellbeing of residents over high-tech industrial expansion.

Thank you for your time and for representing our interests. Please respond back to me so that I know that you read this email. Please let me know how this can be stopped. I hope my voice will be heard and taken seriously.

Here is some more information about the health risk associated to data centers.

1. Empirical research is urgently needed to inform policy. Little is known about long-term health outcomes in data center host communities. Interdisciplinary studies should quantify pollution exposures (Ms.air, water, noise) and track associated health effects.

https://pmc.ncbi.nlm.nih.gov/articles/PMC12273412/?fbclid=IwDGRjcARI6u1jbGNrBEjqr2V4dG4DYWVtAjExAHNydgMGYXBwX2IkDDM1MDY4NTUzMTcyOAABHkPiw_XzjmT68vDLk2-xsqH6LyHACaE0PUyGvKSin4vMnmznHqNq5LCAdygi_aem_w5bQ_8EGg4-c4_BcTOTOig

2. Data Centers behaving like acoustic weapons study

https://m.youtube.com/watch?v=_bP80DEAbuo&fbclid=IwVERDUARI6MtleHRuA2FibQIxMABzcnRjBmFwcf9pZAwzNTA20DU1MzE3MjgAAR4BSI7HsV1aUbkYpEMuH_fFrG0hiPVkPjvcTOSo7aLTyvyzCXliCgBu-kzhcpA_aem_c-7u9kaQ0W3w5I2A7k9YOA

3. Harvard

https://hsph.harvard.edu/news/analyzing-air-pollution-health-economic-risks-from-ai-data-centers/?fbclid=IwDGRjcARI6aFjbGNrBEjpm2V4dG4DYWVtAjExAHNydgMGYXBwX2IkDDM1MDY4NTUzMTcyOAABHkQw0GabePkBVfZpkCMPa3hyQ2eT29iIVYpumwQd_ybWupFHGBwwSjuFY9IA_aem_gkkYkQQv1lppb0yaE7aIEQ

Sincerely,

Wendy Beers

636 East Acorn St.

Gardner, Ks. 66030

913-256-9474

[Sent from AOL on Android](#)

FW: Opposition to data center.

From Donald Roberts <mayor@edgertonks.org>
Date Mon 5/11/2026 10:53 PM
To City Clerk Distribution List <cityclerk@edgertonks.org>

 Internal (mayor@edgertonks.org)

 imagine IT

[Safe](#) [Spam](#) [Phish](#) [More...](#)

From: William La Falce <william.lafalce@gmail.com>
Sent: Monday, May 11, 2026 10:18 PM
To: Donald Roberts <mayor@edgertonks.org>; Clay Longanecker <clonganecker@edgertonks.org>
Subject: Fwd: Opposition to data center.

[External Sender]

----- Forwarded message -----

From: **William La Falce** <william.lafalce@gmail.com>
Date: Mon, May 11, 2026 at 10:14 PM
Subject: Opposition to data center.
To: <Mayor@edgertoks.org>, <clonganecker@edgertonks.org>, <JLewis@edgertonks.org>, <rconus@edgertonks.org>, <dlebakken@edgertonks.org>, <bmalloy@edgertonks.org>, <communitydevelopment@edgertonks.org>

These data centers pose an imminent danger to the community and environment and offer no benefit to the community.

Regardless of what the DAMAC personnel tell you, It is not truthful as seen in other communities impacted by the presence of data centers.

The noise pollution from the hum and back up generators will ruin the pastoral qualities and cause long term harm to human health and the animals in the vicinity. Animals and birds will leave the area and fail to thrive.

Besides the massive impact on water usage, these shortfalls will also impact emergency service response for fires and degrade the quality of life and devalue property. Residents near plants face water shortages, low pressure and the inability to even flush toilets.

If the Data center fails and is abandoned, there is no plan for cleanup and become like GAZA. Another Love Canal of devalued property and no water, pollution and toxic waste.

I have enlisted the aid of the Sierra Club to fight this data center through legislation and litigation.

Collectively and individually you will be held accountable for the decision you make. Be wise and be stewards of our rural heritage

Leave a legacy you all can be proud to claim for your children and childrens children.

A massive QTS Data Centers campus in Fayetteville, Georgia, secretly consumed nearly 30 million gallons of water during construction, causing local water shortages and triggering a \$147,474 retroactive charge. The unmetered usage, discovered in May 2026, occurred during drought conditions, leading to Fayette County pausing new data center projects. [1, 2, 3, 4]

Key Aspects of the Georgia Data Center Problem:

- **Unmonitored Water Usage:** The 615-acre QTS facility used 29 million gallons through two industrial pipes that were either unmonitored or unapproved, which was not discovered for months.
- **Residential Impact:** Residents in the nearby Annelise Park neighborhood reported severely low water pressure, which prompted the investigation that revealed the usage.
- **Construction Demand:** The water was primarily used for dust control and concrete, prompting critics to highlight the high water demand of AI infrastructure.
- **Local Action:** In response, the Fayetteville City Council has moved to ban new data centers, reflecting growing public outrage.
- **Failed Regulations:** Despite the incident, efforts to curb tax breaks for these projects, such as Senate Bill 408, failed to advance in the legislature, meaning tax exemptions

https://www.google.com/search?q=data+center+georgia+problem+&client=ms-android-att-us-rcv3&hs=5wV&sca_esv=10decd1eceb7e98c&biw=411&bih=784&sxsrf=ANbL-n4pOlotPrIss8ZuJZG-pnLRAHFuwg%3A1778184859366&ei=m_L8acCJFr-vqtsPrZ-NkQs&oq=data+center+georgia+problem+&gs_lp=EhNtb2JpbGUtZ3dzLXdpei1zZXJwIhXkYXRhIGNlbnRlciBnZW9yZ2lhIHByb2JsZW0gMgUQIRigATIFECEYoaEYBRAhGKABMgUQIRigATIFECEYoaEYBRAhGJ8FMggQABiABBiiBDIIEAAygAQYogRI3GJQtCJY0VFwAHgCkAEAmAH6laABh2-qAQ0wLjEuMS42LTFuOS00uAEDyAEA-AEBmAIHoAKRX8ICBBAAGEfCAgUQABiABMICBhAAGBYHsICCxAAGIAEGIYDGIoFmAMAIAYBkAYIkgcPMS4xLjEuNi0xLjAuMS4yoAe0LLIHdZuMS4xLjYtMS4wLjEuMrgHi1_CBwLjEuNS4xyAcggAgA&scient=mobile-gws-wiz-serp#fIld=ChxjMe

Data centers pose significant environmental and community risks, primarily through massive electricity consumption, high water usage for cooling, and local air/noise pollution. These facilities can strain power grids, increase utility rates for residents, and cause noise and light pollution, with some emitting harmful pollutants from diesel backup generators. [1, 2, 3, 4, 5]

Key dangers associated with data centers include:

- **Massive Water Consumption:** Data centers use millions of gallons of water for cooling, which can deplete local water resources, especially in drought-prone areas.
- **Air and Noise Pollution:** They are associated with significant noise pollution from cooling systems, and air pollution from backup diesel generators or on-site gas turbines, which emit nitrogen oxides and fine particulate matter.
- **Public Health Risks:** Emissions from data centers, particularly those powered by fossil fuels or using diesel generators, are linked to respiratory diseases, cardiovascular conditions, and increased cancer risks in nearby communities.
- **High Energy Demand:** Data centers are driving up energy demand, causing increased utility rates and straining grid capacity.
- **Environmental Impact:** Data center operations contribute to climate change through high greenhouse gas emissions, and their construction can lead to light pollution and loss of natural habitats. [[1](#), [2](#), [3](#), [4](#), [5](#), [6](#), [7](#)]

These environmental and health impacts are often felt most heavily by local communities in areas where the data centers are built, with reports indicating that some of these impacts are more pronounced in low-income or marginalized communities. [[1](#), [2](#)]

Environmental Impact

[Data Centers Fact Sheet 2 - Data Centers and Environmental Considerations.pdf](#)

[Data Centers | Sierra Club](#)

[More data centers, more environmental problems?](#)

Health Impact

[California data center health impacts tripled in 4 years | UCR News | UC Riverside](#)

[The Health Divide: The AI data center boom will harm the health of communities that can least afford it | USC Center for Health Journalism](#)

Noise, Air and Light Pollution

[The Dangers of Data Centers](#)

[The Real Safety Risks of Data Centers: What Local Communities Need to Know. – Conimby](#)

Water Impact and contamination

[Data Centers, Pollution, and the Communities Left Behind - Sustainability Dialogue](#)

[A data center drained 30M gallons of water unnoticed — until residents complained about low water pressure - E&E News by POLITICO](#)

[Data Center Water Use and Its Environmental Impact](#)

[Data Centers Have a PFAS Problem | Sierra Club](#)

Power Grid and Energy Impact

[NERC Issues Alert on Data Centers Threatening Grid Stability - Business Insider](#)

[Why are communities pushing back against data centers? — Harvard Gazette](#)

This is not emotion, but verifiable information found around the U.S

William La Falce

MEMORANDUM

Date: June 9, 2026
To: City of Edgerton Planning Commission
From: Zachary Moore, Development Services Director
Re: Revised Submittal for **Application FSP2026-0002, Final Site Plan for Edgerton Project**

At the May 12, 2026 Planning Commission meeting, a public hearing was held for **FSP2026-0002, Final Site Plan for Edgerton Project** located at 31800 W. 196th Street, Edgerton, KS. Following deliberation by the Planning Commission, a motion was approved to table the application with a request to obtain more information regarding the generators that are proposed to be used.

The Applicant (Damac Digital Solutions Kansas) submitted new material for the Planning Commission's review and consideration. Those materials are included within this packet and are listed as items 1 through 5 below. Items from the previous Planning Commission packet related to this application are included following.

At the June 9, 2026 Planning Commission meeting, application **FSP2026-0002, Final Site Plan for Edgerton Project** located at 31800 W. 196th Street will be considered.

There will be no additional public comment for this item, as the public hearing was closed on May 12, 2026 during the Planning Commission meeting.

- Attachments:
1. Cover Letter from Husch Blackwell, Applicant's Representative
 2. Damac Digital Solutions Kansas – "Responding to the Commission's Request"
 3. Technical Memorandum – Noise Screening Analysis
 4. Cover Letter From Heartland Data Center/Damac Digital Solutions Kansas
 5. Kansas Department of Health and Environment (KDHE) Emissions Permit Application
 6. Planning Commission Packet from May 12, 2026 Meeting*
** Note: May 12 Agenda, Consent Agenda Items, and Preliminary Plat Information Removed*

NEW INFORMATION PROVIDED BY DAMAC DIGITAL LLC

HUSCH BLACKWELL

Charles G. Renner
Partner

4801 Main Street, Suite 1000
Kansas City, MO 64112
Direct: 816.329.4702
Fax: 816.421.0596
charles.renner@huschblackwell.com

June 2, 2026

Todd Luckman
City Attorney
City of Edgerton, Kansas
404 E. Nelson Street
Edgerton, Kansas 66021

Re: Final Site Plan Application FSP2026-0002 - DAMAC Digital Solutions Kansas LLC -
31800 W. 196th Street, Edgerton, Kansas 66021

Dear Mr. Luckman:

This firm represents DAMAC Digital Solutions Kansas LLC ("DAMAC Digital") in connection with Final Site Plan Application FSP2026-0002 (the "**Final Site Plan**"). We write following the May 12, 2026, City of Edgerton, Kansas (the "**City**") Planning Commission (the "**Commission**") public meeting to formally supplement the record in advance of the Commission's June 9, 2026 meeting. Submitted herewith is a letter from DAMAC Digital and its engineering team, including a professional noise screening analysis prepared by Barr Engineering Co., addressing each of the Commission's stated areas of interest at the May 12th meeting: the project's noise screening, its backup power equipment, and its closed-loop cooling system. As described herein and the enclosed materials, the facility has been deliberately engineered with strict attention to these three areas. Particular emphasis has been placed on the project's acoustic design, so that sound levels reaching the property lines remain low. All supplementary information requested by the Commission has been provided, all applicable review criteria have been satisfied, and there is no factual or legal basis to continue or deny approval of the Final Site Plan.

I. DAMAC Digital Has Provided All Supplemental Site Engineering Information Requested at the May 12, 2026 Commission Meeting

The Commission indicated at the May 12, 2026 meeting that it wished to receive additional information pertaining to Uniform Development Code ("**UDC**") Section 10.1(H)(5) — good land planning and site engineering design principles — before proceeding to a vote. Without conceding that any such information was required to establish compliance with said final site plan review criterion, DAMAC Digital has taken the Commission's request seriously and now submits herewith the supplemental site engineering and technical information requested. This information addresses the project's noise screening, its backup power equipment, and its cooling system, and demonstrates that each reflects sound and deliberate site engineering.

Todd Luckman
June 2, 2026
Page 2

With respect to noise screening, the facility is engineered with strict attention to noise management. The project's chillers and backup generators are enclosed by screening walls up to 35 feet in height, stepping down to 25 feet at the ends of each equipment pod, and the equipment is positioned well inside the property, away from its boundaries — intentional design features of the site plan. To confirm that the design performs as intended, DAMAC Digital retained Barr Engineering Co. to model the project's sound levels. Barr's analysis, enclosed herewith, modeled sound levels at or below 51 dBA at the nearest residence, located approximately 1,500 feet from the nearest equipment, in every operating scenario modeled, including periods of backup generator testing. The higher modeled sound levels remain contained at the screened equipment; only lower levels reach the property lines.

With respect to backup power, the facility includes diesel generators that provide emergency backup power, sized to the building's critical electrical load and arranged in screened equipment pods on the east and west sides of the building. The generators operate only during a utility outage, or for brief periodic testing, averaging one to two hours per month. Air emissions from the generators are regulated by the Kansas Department of Health and Environment under authority delegated by the United States Environmental Protection Agency. DAMAC Digital filed a construction permit application with said agency on May 8, 2026; the application proposes that the facility be permitted as a synthetic minor source, with enforceable fuel and operating limits that hold facility-wide emissions below major-source thresholds. The generator engines meet EPA Tier 2 standards and are fueled by ultra-low-sulfur diesel. The configuration, sizing, and screening of the backup power equipment are elements of the site design; the review of air emissions is a separate state and federal process.

With respect to water use, the facility's cooling system is a closed-loop design: a fully sealed, recirculating system, and not an evaporative or adiabatic system. After a one-time initial fill, the cooling loop does not draw on the public water supply. Routine water use at the facility is limited to ordinary back-of-house functions, at a level comparable to a standard warehouse, and the project requires no water or sewer infrastructure upgrades. The selection of a closed-loop cooling system is itself a site engineering decision, made to minimize the project's water demand. The cooling system is further protected by leak detection tied to the building's management system, rapid isolation, and secondary containment around the cooling equipment.

This supplemental submission addresses the Commission's stated concerns fully and confirms that the Final Site Plan is consistent with good land planning and site engineering design principles, as required by UDC Section 10.1(H)(5).

II. Noise Is Not a Site Plan Review Criterion Under the UDC and Does Not Provide a Basis for Withholding Approval

The Commission raised questions about noise at the May 12, 2026 meeting, and the engineering analysis in Section I answers them directly: the facility is projected to operate below the level of normal conversation at the nearest residence, nearly 1,500 feet away. DAMAC Digital provides that analysis in the interest of transparency and as a responsible neighbor. As a legal matter, however, noise is not a cognizable criterion under UDC Section 10.1(H) site plan review standards. None of the eight site plan review criteria enumerated in UDC Section 10.1(H) incorporates or implies a noise threshold, noise measurement standard,

Todd Luckman
June 2, 2026
Page 3

or noise control requirement. The UDC simply does not regulate operational noise as a condition of site plan approval, and the Commission may not lawfully rely upon it as a basis to continue or deny the Final Site Plan.

It is also important to note that the UDC does not contain any noise standard specifically applicable to data centers or most commercial developments. The UDC's one numeric noise standard — a performance provision in Article 7 that applies to cargo container facilities, which are a conditional use in that district — permits 70 dB(A) at an adjacent commercial or industrial district. The project is not subject to that provision but models well below it, as reflected in the Barr Engineering analysis described in Section I. Noise at the facility is instead governed by the City's general noise ordinance, Chapter XI of the City Code, which is a nuisance-type noise ordinance, separate from the UDC and applying to all properties alike. Enforcement of this ordinance, to whatever extent applicable, is a matter within the jurisdiction of law enforcement, not the Planning Commission. Regardless, the project's design and modeled performance are consistent with City Code Chapter XI, as demonstrated by the Barr Engineering analysis. DAMAC Digital reiterates its clear commitment to complying with all applicable noise requirements within the UDC and City Code.

The point is that whatever noise-related obligations may exist are governed by law enforcement and permitting regimes that operate independently of the Planning Commission's site plan review function. The Commission may not, consistent with the UDC and the legal limitations on quasi-judicial land use authority, substitute noise concerns for the codified review criteria or withhold site plan approval on grounds that the code does not authorize it to consider. The engineering information provided in Section I is submitted solely in the interest of transparency and community confidence.

III. The Open Record Reflects the Commission and Counsel's Acknowledgment That All Review Criteria Are Satisfied

The legal posture of the Final Site Plan is reinforced by the Commission's own conduct at the May 12, 2026 meeting. As your office and the Planning Commission acknowledged during the course of the Commission's discussion, the Final Site Plan as submitted meets all of the applicable site plan review criteria under the UDC. We are in full agreement with that assessment, which is entirely consistent with city staff's written recommendation of approval and the thorough compliance analysis set forth in the staff report. We formally confirm that acknowledgment as part of the record.

That acknowledgment carries significant legal weight. The Planning Commission's authority to approve or deny a final site plan application is bounded by the criteria set forth in UDC Section 10.1(H). Having collectively acknowledged on the record that all eight criteria therein are satisfied, the Commission's discretionary range of action is correspondingly constrained. A quasi-judicial body exercising limited, criteria-based authority may not deny or withhold action on an application where the record affirmatively establishes compliance with every applicable standard. The Commission's subsequent decision to continue the vote does not alter the legal landscape. It simply means that the record now additionally reflects the supplemental engineering information provided in Section I, further reinforcing a conclusion the Commission itself had already reached. We trust this principle is consistent with how the City intends to proceed.

Todd Luckman
June 2, 2026
Page 4

IV. Background: The Final Site Plan's Compliance with the Applicable Review Criteria

For context, we briefly summarize the record as it stood at the close of the May 12, 2026 public meeting. UDC Section 10.1(H) sets forth the exclusive criteria by which the Planning Commission evaluates and acts upon a site plan application. Each of these criteria is directed at the design and engineering of the plan — its open space, utilities, stormwater management, traffic circulation, engineering design, architecture, landscaping, and consistency with the Comprehensive Plan. None addresses the operational characteristics of the completed facility. City staff, in its written staff report prepared and presented for the May 12, 2026 meeting, thoroughly analyzed the Final Site Plan against each of these criteria and against all applicable L-P District zoning standards, and recommended approval of the Final Site Plan. The staff report documents compliance across every relevant regulatory requirement. By way of summary:

- **Criterion 1 (Site Capacity — Open Space and Landscaping):** The subject property totals 2,343,242 square feet in size, of which approximately 1,219,417 square feet (52.04%) is proposed as open space at build-out, exceeding the L-P District's minimum 50% open space requirement.
- **Criterion 2 (Utilities):** The site plan includes dedicated electrical infrastructure, including two new medium-voltage intake buildings and an on-site electrical substation, with power delivered via dedicated high-voltage infrastructure coordinated directly with Evergy.
- **Criterion 3 (Stormwater):** A stormwater management study and plan has been provided and reviewed by the City Engineer. As reflected in the staff report, the City Engineer's remaining comments — together with the floodplain and floodway permits and related bridge details — are to be satisfied prior to issuance of a building permit, and city staff included them as conditions of its recommendation of approval. The applicant has acknowledged these requirements.
- **Criterion 4 (Ingress, Egress, and Traffic Circulation):** A gate is proposed at the northern portion of West 196th Street on private property, approximately 38 feet from the public right-of-way, with all drivers entering the site pre-authorized to enter, reducing wait times and minimizing vehicle queuing on the adjacent right-of-way. An Ingress/Egress Analysis was included in the submitted plan set.
- **Criterion 5 (Good Land Planning and Site Engineering Design Principles):** City staff analyzed the Final Site Plan against this criterion and confirmed compliance, recommending approval without qualification. DAMAC Digital has now provided the supplemental site engineering information requested by the Commission, as set forth in Section I above. This criterion is satisfied.
- **Criterion 6 (Architectural Compatibility):** The main building's architecture was approved under Final Site Plan FS2016-04, and no architectural modifications are proposed. The two new MV intake buildings will be constructed of concrete walls, and the guard shack of concrete and glass, consistent with the existing building's tilt-up concrete construction and compliant with UDC requirements.
- **Criterion 7 (Landscaping, Screening, and Buffering):** DAMAC Digital is proposing the removal of 50 existing trees and the planting of 79 new trees and 203 new shrubs, including 55 evergreen white pines along the east and west of the proposed substation. A 10-foot tall black fence designed to prevent damage caused by common tools is proposed around the perimeter of the property, compliant with the City's fencing requirements.

HUSCH BLACKWELL

Todd Luckman
June 2, 2026
Page 5

- **Criterion 8 (Consistency with the Comprehensive Plan):** The proposed data center use has been confirmed as permitted by right in the L-P (Logistics Park) Zoning District by the City's Development Services Director. No rezoning, variance, or special use permit is required in connection with this application.

On the face of the record that existed at the close of the May 12, 2026 public meeting, the Final Site Plan met every one of the eight applicable review criteria. The supplemental site engineering information now provided only reinforces that conclusion.

V. The Planning Commission Is Required to Approve the Final Site Plan

To summarize the posture of this application:

- City staff reviewed the Final Site Plan against every applicable zoning standard and all eight UDC Section 10.1(H) review criteria, and recommended approval.
- DAMAC Digital has provided comprehensive supplemental site engineering information addressing UDC Section 10.1(H)(5), as detailed in Section I, including a professional noise screening analysis, backup power design and permitting information, and documentation of the facility's closed-loop cooling system. All information requested by the Commission has been provided in full.
- Noise is not a cognizable criterion under the UDC Section 10.1(H) and falls within the jurisdiction of law enforcement, not the Planning Commission. As detailed in Section II, the Commission may not lawfully condition or withhold site plan approval on the basis of operational noise concerns that are neither defined nor regulated within the UDC.
- The City Attorney and the Planning Commission acknowledged on the open record at the May 12, 2026 meeting that the Final Site Plan meets all applicable review criteria, as set forth in Section III. DAMAC Digital is in full agreement with that assessment.

The Planning Commission's authority over the Final Site Plan application is defined and constrained by the criteria in UDC Section 10.1(H). Where the record demonstrates that all applicable criteria are satisfied, the Commission does not have discretion to deny or indefinitely withhold approval. To do so would expose the City to legal challenge and would be inconsistent with the Commission's obligations under the UDC.

We respectfully request that Final Site Plan Application FSP2026-0002 be placed on the agenda for the Commission's next scheduled meeting on June 9, 2026, and that the Commission proceed to a vote and approve the application at that meeting. We are available to meet with your office in advance of that meeting to address any remaining questions and trust that we share a mutual interest in bringing this matter to a lawful and timely conclusion.

The enclosures referenced herein are submitted herewith for inclusion in the record.

Please do not hesitate to contact me directly with any questions or to discuss the matters addressed herein.

HUSCH BLACKWELL

Todd Luckman
June 2, 2026
Page 6

Enclosures:

1. Project Heartland, Response to the Planning Commission's May 12 Request (June 1, 2026)
2. Barr Engineering Co., Project Heartland Noise Screening Analysis (June 1, 2026)
3. DAMAC Digital Solutions Kansas LLC, Applicant Letter (June 1, 2026)

Respectfully,

HUSCH BLACKWELL LLP



Charles G. Renner



CITY OF EDGERTON PLANNING COMMISSION · JUNE 9, 2026

Responding to the Commission's Request

DAMAC is here to build a world-class data center in Edgerton — responsibly, with real safeguards, and as a genuine partner to this community.



You Raised These Questions. Here Are Our Answers.

At the May 12 hearing, the Commission and staff raised real questions. We took every one seriously — and here, we answer them in plain terms.

“Is a data center even right for this site?”



The Site

“Could it drain our water — or risk Hillsdale Lake?”



Water & Cooling

“How loud will the facility actually be?”



Noise

“Will the generators pollute our air?”



Air

“What happens to all the old equipment and e-waste?”



Equipment

“Who is DAMAC — and will they be a real partner?”



Community

An Existing Building in an Established Industrial Park

This isn't new industrial development on open land. It's the adaptive reuse of an existing, vacant warehouse in an established industrial park.



378,000

sq ft — existing warehouse, built 2016

53.79 ac

the entire site in this application

Logistics Park KC

a master-planned industrial park

The full site is before you: The plan uses the entire property. The only adjacent land the applicant owns is constrained by floodway and floodplain, and it owns no other neighboring property. If circumstances ever changed, any expansion would require its own application — back before this Commission.

Site: 31800 W. 196th St., in Logistics Park Kansas City. Zoned L-P (Logistics Park); existing 378,038 sq ft warehouse developed in 2016. This application covers the entire site. Per the City staff report.

The Cooling System Is Filled Once — Then Sealed

After a one-time fill, the system recirculates the same fluid in a sealed loop — without drawing additional public water or discharging cooling fluid.

615,000

gallon one-time fill

Filled one time, then recirculated continuously — the system draws no ongoing public water. Everyday domestic use is covered separately.

CLOSED-LOOP, EXPLAINED

Fill it once and it recirculates the same fluid continuously — heat is carried outside and released to the air, then the cooled fluid returns. No top-ups from the public supply.

WHAT'S IN THE LOOP

A one-time fill of about 615,000 gallons — roughly 65% water and 35% propylene glycol, the same low-toxicity fluid used in food, medicines, and home winterizing.

WHY IT MATTERS HERE

A comparable evaporative system would draw **on the order of 30 million gallons a month** from the public supply — and never stop. Our loop is filled once with about 615,000 gallons and recirculated.

The loop is never dumped or flushed; fluid chemistry is monitored regularly so the original fill lasts.

How a Closed-Loop Cooling System Works

This is NOT a cooling tower, and NOT an evaporative or adiabatic system.
No steam plume · no spray · no water evaporated to cool · no continuous water consumption.

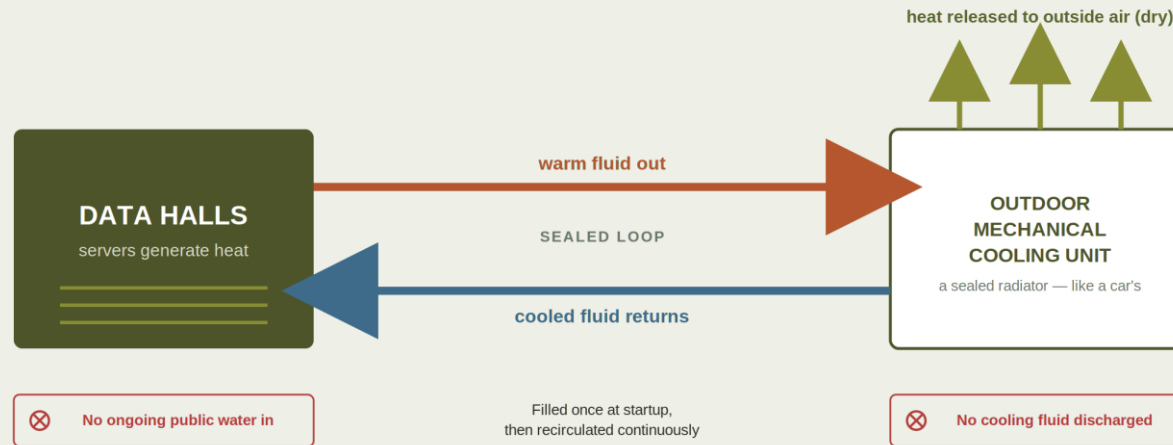

WHAT THIS MEANS

- Heat is rejected to the outside air mechanically — by fans moving air across a sealed coil, the same principle as a car radiator. Cooling towers and evaporative systems, by contrast, cool by evaporating large volumes of water into the air.
- Because nothing evaporates, the same fluid stays in the loop — filled once and recirculated, with no ongoing draw on public water. That design is built into the approved site plan: a switch to water-cooling would need a different layout — and a return to the Planning Commission.

ABOUT PROPYLENE GLYCOL

Propylene glycol is a low-toxicity fluid the FDA recognizes as safe in food, medicine, and personal-care products — and it's the same antifreeze used to winterize homes and RVs.

Source: U.S. CDC / ATSDR.

If Something Goes Wrong: Detect, Isolate, Contain

The cooling system is sealed, so there is no routine discharge — and layered safeguards keep the fluid contained if anything goes wrong.

1

DETECT

Spot and rope leak sensors throughout the cooling equipment, monitored 24/7 by the building management system.

2

ISOLATE

Shut-off valves stop flow once a leak is detected; redundancy isolates a unit without disrupting operations.

3

CONTAIN

Drip pans and curbing beneath the cooling equipment catch any escaping fluid locally — keeping it off the floor and away from drains.

4

REMOVE

Captured fluid is recovered and hauled offsite by a licensed handler — never washed to a drain.

The system is sealed — no routine discharge, and no pathway to Hillsdale Lake or local groundwater.

Any incidental loss is small and dilute (the fluid is about two-thirds water), caught locally by drip pans and curbing, and removed by a licensed waste hauler. Any discharge to the public sewer is governed by the City and Sewer District's regulations — and Heartland operates within them.

Everyday Water Use Is Just Bathrooms and Irrigation

Separate from the one-time cooling fill, the facility's only routine water use is ordinary domestic demand — restrooms for a small on-site crew, plus modest seasonal irrigation.

≈ 2,500

gallons per day

Less than a third of a single 200-seat chain restaurant — about 8,000 gallons a day at 40 gallons per seat.

About the same as 5–8 family homes on a typical street (EPA: ~82 gal/person/day).

WHAT THE WATER IS FOR

Ordinary restroom use — the sinks and toilets used by staff. This is the facility's only routine, everyday water demand.

A LIGHTLY STAFFED SITE

The building runs on a small crew — about 25 people across a 24-hour day — so domestic demand stays low, calculated by standard plumbing-code methods.

THE COOLING SYSTEM ADDS NOTHING

The sealed cooling loop is filled once and recirculated, so it places no ongoing demand on the public supply. Everyday use is domestic only.

This domestic demand is the facility's only routine water use. It also includes modest seasonal irrigation.

Quieter Than the Sounds We Live With Every Day

Barr Engineering Co. models 46 dBA at the nearest home on a hot summer day — and 51 dBA even during the once-a-year generator test. These are conservative estimates; real-world levels are likely lower.

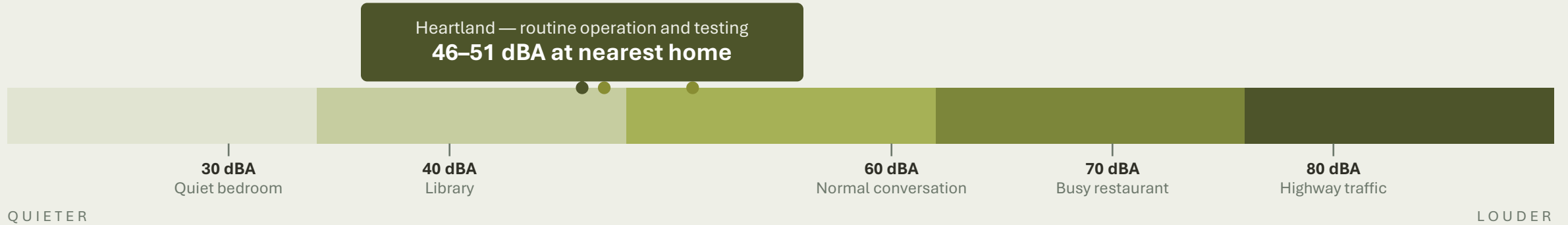

The nearest home sits about 500 feet from Interstate 35 but roughly 1,500 feet from the facility — nearly three times closer to the highway than to the project.

SOUND IS CONTAINED AT THE SOURCE

The generators include built-in attenuation — insulation that keeps sound from traveling — and both chillers and generators sit behind screening walls up to 35 ft tall, so the loudest sound stays on site.

COMFORTABLY BELOW RELEVANT BENCHMARKS

The City's noise rule is qualitative, with no numeric threshold. For context, the project measured itself against the strictest numeric figure anywhere in the City's code — 70 dB(A) at an industrial boundary — and comes in roughly 20 dB under even that reference.

TESTING ON A NEIGHBORLY SCHEDULE

Beyond outages, testing is brief — monthly and annual — and stays well within the limits set by permit. DAMAC voluntarily commits to routine testing **on weekdays only, 8 a.m.–6 p.m.** The generators will of course run whenever needed during an actual outage.

Modeled sound levels per Barr Engineering Co. using the ISO 9613-2 propagation method (iNoise modeling platform); full Noise Screening Analysis, including contour maps, included with this presentation.

What the Facility Sounds Like, by Operating Condition

Three scenarios, from a hot summer day to the once-a-year generator test. In every case, no more than 51 dBA at the nearest home.

All three conditions cluster between 46 and 51 dBA — below normal conversation

Library 40

46–47 dBA

51 dBA

Conversation 60

HOT SUMMER DAY

46 dBA at nearest home



MONTHLY TEST

47 dBA at nearest home



ANNUAL TEST

51 dBA at nearest home



Only the cooling system runs, on a hot summer day — the loudest a normal day gets.

A brief monthly generator check, run with peak cooling — just above a normal day.

Once a year, a longer full-load test — the loudest case, still below conversation.

⌘ [Click any map to view it full-size.](#)

Testing follows a standby-power protocol (consistent with NFPA 110): brief monthly checks, a longer annual load test. Per Barr Engineering Co.; 50 dBA ≈ a quiet office.

Backup Power for Outages — Permitted by the State

The generators exist for one reason — to keep the facility running during a power outage. Apart from outages, they run only for brief scheduled testing.

99%+

of the year — off

The engines sit idle almost all year. Apart from actual outages, testing is brief and strictly capped by permit — and real testing runs well below that limit.

WHY THEY'RE HERE

A data center is built so a power loss never interrupts the services running on it. The generators are that safeguard — if the grid ever goes down, they carry the facility until power returns. Rarely needed, but essential when they are.

CLEAN AND LOW-SULFUR BY DESIGN

All 61 standby engines — sixty Caterpillar 3516C units plus one C32B — are EPA Tier 2 certified and run on ultra-low-sulfur diesel.

PERMITTED AND REGULATED BY THE STATE

Filed with the Kansas Department of Health and Environment (KDHE) in May 2026 under EPA-delegated authority. Permitted as a “synthetic minor” — DAMAC accepts binding, enforceable limits that keep emissions below the federal “major-source” threshold.

These are Tier 2-certified engines burning ultra-low-sulfur diesel, and enforceable permit limits hold facility-wide emissions below major-source thresholds — so their effect on local air quality stays minimal, consistent with the State's air-permitting review.

Secure, and Circular by Design

Because servers hold sensitive data, retired equipment can't simply be thrown out — data security requires that every unit move through a controlled, documented chain of custody. That same process is what keeps the hardware out of the landfill.

1

SECURE DATA DESTRUCTION

Every drive is wiped or physically destroyed to recognized data-sanitization standards, with documented certificates of destruction.

2

REFURBISH & REUSE

Sanitized hardware that still has useful life is tested, refurbished, and returned to service — extending the life of the equipment rather than discarding it.

3

RECOVER MATERIALS

What can't be reused goes to certified electronics recyclers, where metals and components are recovered and fed back into the supply chain.

4

ESSENTIALLY CIRCULAR

The result is a closed loop: data stays secure, value is recovered, and decommissioned equipment goes to certified recyclers — not to a landfill.

Always improving: as technology advances, the facility can adopt more efficient equipment over time — efficiency that benefits everyone.

Decommissioning is an operator function; described here as the standard, certified industry process the facility's operator will follow.

A Long-Term Partner in Edgerton

We're not just here to build — we want to invest in Edgerton's people, starting with the skills that will define the next generation of work.

A PROPOSED COMMUNITY PROGRAM

The Edgerton Coding Initiative

Free, and open to all ages — students and adults alike would gain access to coding and computer-skills training, building the skills that define the next generation of work.

Through the DAMAC Foundation, DAMAC has backed large-scale coding-education programs reaching hundreds of thousands of students — and proposes to bring that same focus to Edgerton. The Initiative would sit alongside DAMAC's broader support for the local causes and organizations that matter to the community.

500+

construction jobs during the build

15–30

permanent on-site jobs once operating

\$700M

estimated total project investment

\$5M+

for Edgerton streets and stormwater

Job, investment, and streets and stormwater figures are current estimates; the Coding Initiative's goals and structure would be shaped to the community's needs.

You Asked. We Answered.

The questions the Commission and staff raised at the hearing — and our answer to each.

WHAT YOU RAISED	OUR ANSWER
THE SITE <i>Is a data center right for this site?</i>	Yes — it reuses an existing 378,000 sq ft warehouse in an established industrial park.
WATER & COOLING <i>Will it drain our water or risk Hillsdale Lake?</i>	A sealed loop, filled once — almost no ongoing public water, nothing discharged, and no pathway to Hillsdale Lake or local groundwater.
NOISE <i>How loud will the facility be?</i>	Modeled at 46 dBA at the nearest home — quieter than normal conversation ; 51 dBA at the once-a-year test.
AIR <i>Will the generators pollute our air?</i>	Tier 2 engines on ultra-low-sulfur diesel, state-permitted below major-source limits, and idle almost all year.
EQUIPMENT <i>What happens to all the e-waste?</i>	Securely wiped, then refurbished or recycled by certified handlers — kept out of the landfill.
COMMUNITY <i>Will DAMAC be a real partner?</i>	Local jobs through build and operation, plus a proposed free coding and skills program for Edgerton.

APPENDIX

Supporting Material

[Equipment at a Glance
Detail](#)

[How the Water Figures Are Calculated](#)

[City Sewer Code](#)

[Project Renderings](#)

[Sound Modeling](#)

Equipment at a Glance

A plain-language summary of the major equipment. Complete manufacturer data sheets are provided in Appendix C of the permit application.

Backup generators — data halls

Sixty Caterpillar 3516C-HD units, 2,500 kWe (3,125 kVA) each at 0.8 power factor · 480 VAC, 60 Hz · EPA Tier 2 · ultra-low-sulfur diesel · permanent-magnet excitation · UL2200 listed and seismically certified · Modbus TCP/IP to the building management system.

Backup generator — house load

One Caterpillar C32B-class unit, 1,500 kWe (1,875 kVA) at 0.8 power factor · 480 VAC, 60 Hz · EPA Tier 2 · ultra-low-sulfur diesel · serves house/critical building loads in an outage.

Cooling units

Vertiv CoolLoop Thermal Wall (CA60) · sealed closed-loop, chilled-water configuration · EC variable-speed fans · Liebert iCOM controls with 65 kA short-circuit rating · Liqui-tect leak detection · BACnet/Modbus to the building management system.

Cooling fluid

One-time fill of about 615,000 gallons · roughly two-thirds water, one-third propylene glycol (freeze protection to about -13.8°F) · no corrosion inhibitors or biocides · no ongoing public-water draw.

See Appendix C-1 and C-2 (Manufacturer Specifications) of the permit application for complete equipment data sheets.

How the Water Figures Were Calculated

The facility's only routine water use is ordinary back-of-house (restroom) demand — calculated using standard engineering and plumbing-code methods.



CAPACITY & FIXTURES

- The 2,500 gpd flow is well within the capacity of the existing 8-inch sewer connection (rated for 1,400 drainage fixture units per IPC 2018 §710.1). No water or sewer upgrades are required.
- Fixtures are sized to the same occupancy per IPC 2018 §403.1: about 31 water closets, 25 lavatories, 10 urinals, and additional fixtures (266 drainage fixture units total).
- Cooling adds no routine demand: the closed loop is filled once (≈ 615,000 gallons) and recirculated. Modest seasonal irrigation adds a few thousand gallons on average.

Managing the Fluid — Within the City's Sewer Code

Edgerton's Sewer Use Regulations (City Code Ch. XV, Art. 2) govern what may enter the public sewer. The facility manages its cooling fluid within these rules.

WHAT THE CODE GOVERNS

§ 15-227 Cooling and unpolluted process water are kept out of the sanitary sewer.

§ 15-228/229 The superintendent may prohibit or regulate discharges that could harm the system — including oxygen-demanding wastes (Biochemical Oxygen Demand, or BOD).

§ 15-231 Any discharge above a 5-day BOD of 300 ppm needs the superintendent's review, approval, and pretreatment if required.

§ 15-232/233 The City may require sampling and enter special agreements for industrial waste — at the user's expense.

HOW THE FLUID IS MANAGED

1 Normal operation
Nothing is discharged — the sealed loop recirculates the same fluid.

2 Routine maintenance
Any fluid removed is captured and hauled offsite by a licensed waste hauler — the primary pathway, no sewer involved.

3 Incidental release
Caught by secondary containment, then recovered — not washed to any drain.

4 Any sewer discharge
Only with the superintendent's review and approval under §§15-231/233.

In short: there is no discharge of cooling fluid in normal operation; the primary pathway is offsite hauling by a licensed handler, and any discharge to the public sewer is governed by the City's code.

Project Renderings



Overall Site Aerial



Aerial at Main Entrance



View — Northeast of Site



View — Southeast of Site

Sound Modeling — Normal Operation

46 dBA at the nearest home · chillers at peak summer cooling demand



Sound Modeling — Monthly Generator Test

47 dBA at the nearest home - brief monthly test, plus peak cooling



Sound Modeling — Annual Generator Test

51 dBA at the nearest home · once-a-year full test (loudest case)



Technical Memorandum

To: DAMAC Digital Solutions Kansas LLC
From: Andrew Skoglund
Subject: Noise Screening Analysis – Project Heartland (Preliminary Plat PP2026-0001 and Final Site Plan FSP 2026-0002)
Date: 6/1/2026
Project: 16/46-1001
c: Kim Alfonsi

The noise modeling results described in this memo are being provided to support the regulatory review process of the proposed Project Heartland (Heartland). Barr Engineering Co. conducted noise modeling of the potential sound levels of the project chillers as well as configurations with four generators operating simultaneously under monthly and annual testing operations. Sound levels for input to the modeling are based on manufacturer specifications provided by Project Heartland representatives.

Executive Summary

The noise modeling for the Site was conducted using manufacturer source and controls data provided by Heartland applied to the site-specific configuration of the proposed site. This information was then used as input to a standard noise model to estimate potential noise levels likely to occur in the vicinity under three operating scenarios.

Modeled scenarios reflect summer operating conditions, with the day-to-day chiller operation modeled at the 70% cooling load, as representative of high cooling demand summer conditions. Generator operation was based upon anticipated simultaneous testing of four generators at 30% load on a monthly basis and at 100% load on an annual basis.

The model predicts project-related noise levels at or below 51 dBA at nearby residences. The nearest residence to the site is between the site and I-35 to the southeast, located approximately 500 feet from I-35 and 1500 feet from the nearest project generator or chiller unit. As context, the area's existing noise environment is currently influenced by Interstate 35 and nearby rail and industrial activity. Other activity in the area includes existing warehouses to the immediate east of the project, as well as an intermodal yard to the north. Diesel engines from both trucks and locomotives are likely existing sound types for the general project area. Modeled sound level contour footprints extend somewhat farther between the buildings versus the more open west side given the expected reflection effects.

Overall, the analysis indicates that the project will have a relatively limited noise footprint. The modeled levels at the nearest residence remain at or below 51 dBA in all three scenarios with the more noticeable increases during occasional periods of daytime generator testing.

Basics of Noise

Noise levels are usually measured in units of decibels (“dB”). For applications where human hearing is the prime consideration, A-weighting is applied to yield A-weighted decibels (“dBA”). This weighting serves to better replicate the way the human ear perceives sound. A level of 0 dBA is nominally the threshold of hearing, below which a healthy human ear cannot detect sound. Most situations never yield levels this low, with a quiet bedroom falling around 30 dBA. Decibels are on a logarithmic scale, thus add logarithmically rather than arithmetically. Combining two equal sound levels results in a net increase of +3dBA. For example, a 37 dBA new source added to a 37 dBA background level results in a combined sound level of 40 dBA. A just barely perceptible change in sound level is considered to be 3 dBA, while an increase in dBA of 10 is perceived as a doubling of the sound level.

Table 1. Comparative Noise Levels¹

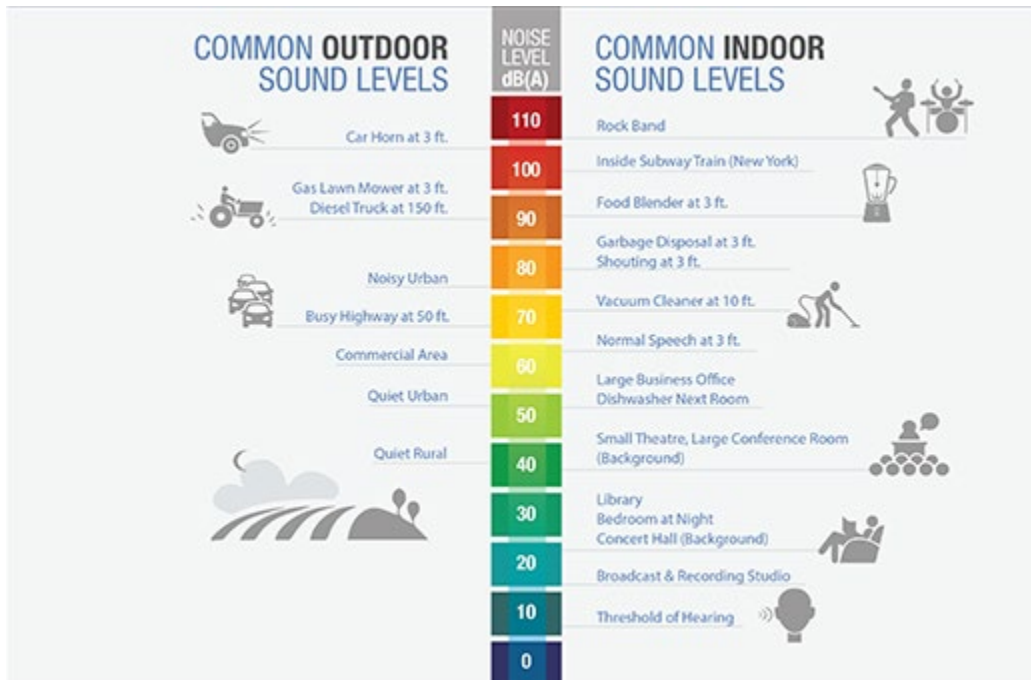

Applicable Noise Standards

A review of state and local regulations and communications with Heartland representatives indicate there is no explicit numeric sound-level threshold applicable to site plan or plat approval for the project. The City’s general noise regulation is contained in Chapter XI, Article 6 of the City Code (Public Offenses) and is qualitative rather than numeric in nature.

¹ Note. Adapted from “Fundamentals of Noise and Sound,” by Federal Aviation Administration, 2022, https://www.faa.gov/regulations_policies/policy_guidance/noise/basics

Modeling Methodology

The manufacturer octave-band sound pressure level data provided by Heartland representatives was converted to equivalent sound power levels for input to the iNoise noise propagation modeling software. The iNoise software used the standard ISO9613 noise propagation methods to project source sound levels in the area surrounding a facility. The ISO9613 method is widely accepted as a standard basis for environmental noise modeling in the United States, as it provides a conservative, downwind-based estimate of sound propagation under typical atmospheric conditions.

Specific iNoise model settings included:

- Atmospheric attenuation based on default temperature of 20°C and Relative Humidity of 60%.
- Ground hardness for the domain was set to 0.5 (mixed hardness), conservatively selected given the mix of agricultural and commercial land use in the area consisting of a mixture of 'soft' and 'hard' ground per the ISO definitions.
- Receptor height of 2 meters. This elevation approximates an average listening height.
- Foliage-based attenuation is conservatively excluded.
- Terrain effects are excluded as a simplifying approach, given the relatively level project area

Source characterization included using the specified levels to calculate and create sources equivalent to chillers, emergency engine enclosures, and emergency engine exhaust stacks within the model. Project structure and screening wall heights were derived from site architectural drawings and notes included in the site plan application. Key source characteristic assumptions include:

- Solid Primary screening walls with height to 35 feet where adjacent to chillers/generators, stepped down to 25 feet at the north and south portion of each pod of units.
- Generator enclosure noise modeled as split source, one source just outside screening wall to represent intake louver, another source inside wall representing remainder of enclosure. Conservatively assumed 70/30 split of sound energy emission from intake vs remainder of enclosure given limited enclosure specifications at this stage of design
- Current enclosure performance specification is broadband 73 dBA at 23ft. Engine mechanical noise spec by octave band applied scaled typical enclosure performance value by octave band to align with the 73 dBA overall specification for net modeled enclosure emissions
- Acoustical louvers through the screening walls mitigating intake noise as specified in Ruskin ACL445 specifications provided via email 5/27/2026
- Chiller specifications as provided via email 5/18/2026
- Generator stack height of 35 feet

There are three facility configurations modeled, representing different operational scenarios. The "Peak Summer Cooling Demand (Chillers Only) case entails a representative day of facility operations, with chillers operating at 70% load for high summer demand, and power provided by the grid. The second configuration (Monthly Generator Test) continues this summer chiller operation, with the addition of four

emergency generators undergoing simultaneous testing, at 30% load consistent with NFPA 110 monthly testing requirements. The third configuration (Annual Generator Test) largely duplicates the second case but increases the tested engine load to 100%, as may be required for an annual test event.

Modeling Results

Noise levels were predicted using the ISO 9613-2 methodology as implemented in the iNoise modeling platform. This method provides conservative, steady-state estimates under acoustically favorable propagation conditions. Results are subject to inherent limitations related to meteorological assumptions, source characterization, terrain representation, and model simplifications. Accordingly, predicted sound levels should be considered reasonable approximations, and actual sound levels may vary depending on site-specific conditions and operational variability.

Modeled sound levels for areas near the project are provided in Figures 1 through 6. Modeled project sound level at the nearest apparent residence to the southeast remains below 51 dBA. Modeled levels from the four southeast-most generators under testing are shown in the figures, given their proximity to the nearest residence. Similar footprint extents are expected for testing of the other generators at the site.

	Modeled Project Sound Pressure Level (dBA)		
	Peak Summer Cooling Demand (Chillers Only)	Monthly Generator Test (4 Units)	Annual Generator Test (4 Units)
Nearest Residence	46	47	51

For many receptors, the project contribution is likely to represent only a modest increase compared to background conditions (typically 1–5 dBA). Generator testing is an intermittent activity at the site, and does not represent continuous or typical operational conditions.

Across all three modeled scenarios, the maximum modeled noise level at a residential receptor is at or below 51 dBA.



Barr Footer: ArcGISPro 3.6.1, 2026-06-01 15:22 File: \\Projects\16461001\MapasProj_Heartland_Noise_Memo_01\UN2026_final_memo.aprx Layout: Fig1_Chillers Only User: ajs

- - - Property Boundary
- Screening Walls
- Nearest Residence

Modeled dBA

- 50
- 55
- 60
- 65
- 70

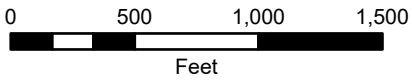

**Peak Summer
Cooling Demand
Chillers Only**
Project Heartland
Edgerton, KS

FIGURE 1

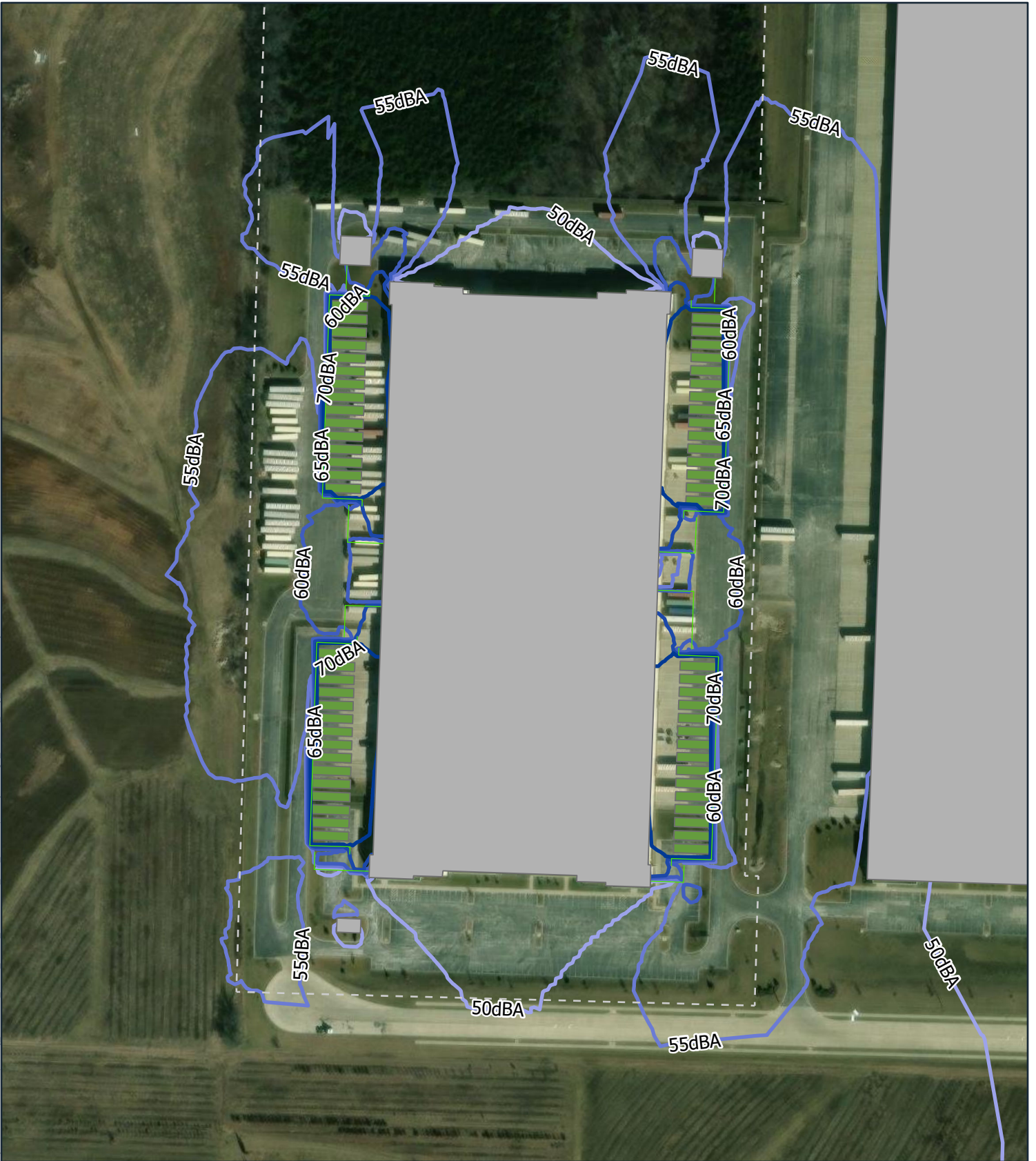

- - - Property Boundary
- Screening Walls
- Nearest Residence

Modeled dBA

- 50
- 55
- 60
- 65
- 70

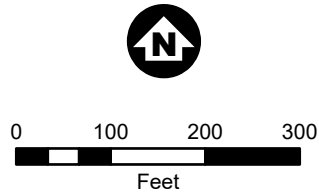

**Peak Summer
Cooling Demand
Chillers Only - Detail**
Project Heartland
Edgerton, KS

FIGURE 2



Barr Footer: ArcGISPro 3.6.1, 2025-06-01 15:22 File: J:\Projects\16461001\MapsaProj - Heartland Noise Memo_01 JUN2025 final_memo.aprx Layout: Fig3_Monthly_Gen_Testing User: ajs



- - - Property Boundary
 - Screening Walls
 - Nearest Residence
- Modeled dBA - 4 SE Units Testing
- 50
 - 55
 - 60
 - 65
 - 70

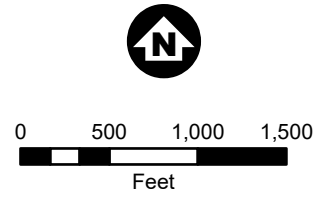

**Monthly Generator Test
Chillers at Peak Summer
Cooling Demand
Project Heartland
Edgerton, KS**

FIGURE 3

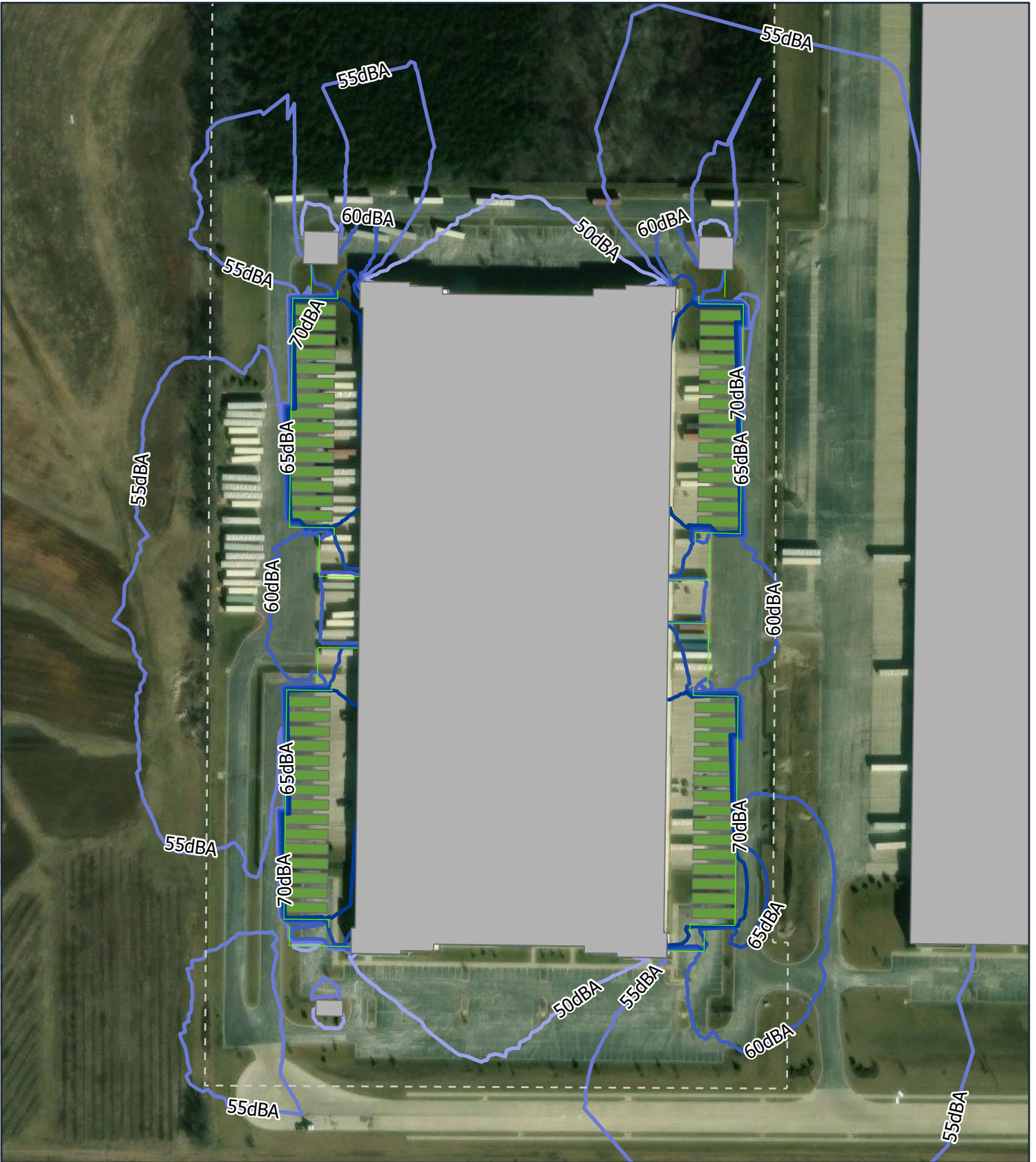

- - - Property Boundary

— Screening Walls

Modeled dBA - 4 SE Units Testing

- 50
- 55
- 60
- 65
- 70

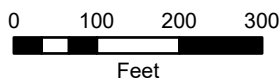

Monthly Generator Test Chillers at Peak Summer Cooling Demand - Detail
Project Heartland
Edgerton, KS

FIGURE 4



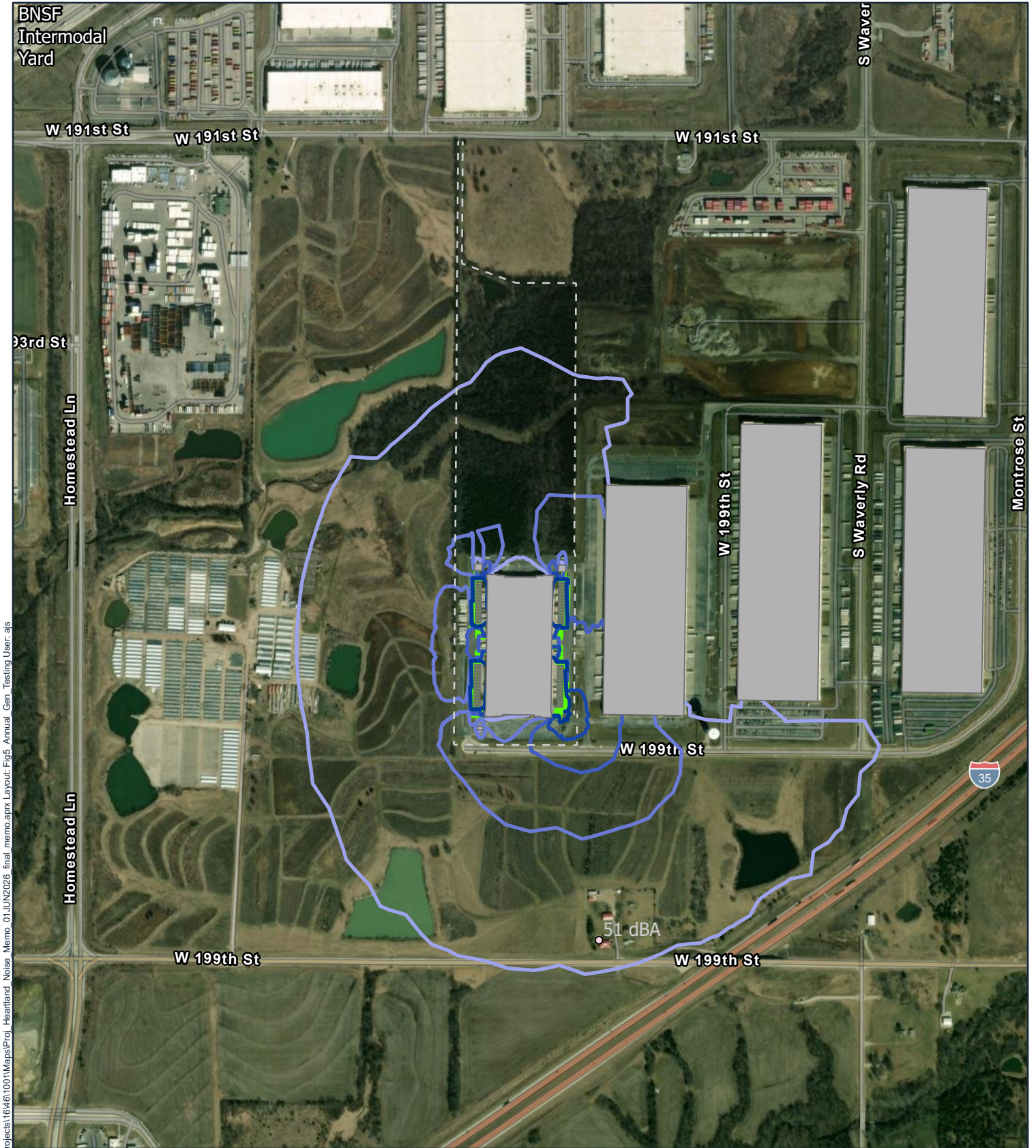

Barr Footer: ArcGISPro 3.6.1, 2025-06-01 15:22 File: J:\Projects\16461001\Mapas\Proj - Heartland Noise Memo_01\UN2025_final_memo.aprx Layout: Fig5_Annual_Gen_Testing User: ajs

- - - Property Boundary
 - Screening Walls
 - Nearest Residence
- Modeled dBA - 4 SE Units Testing**
- 50
 - 55
 - 60
 - 65
 - 70

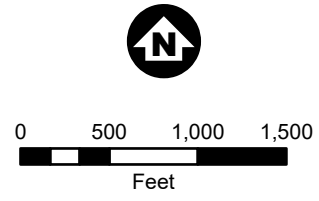

**Annual Generator Test
Chillers at Peak Summer
Cooling Demand
Project Heartland
Edgerton, KS**

FIGURE 5



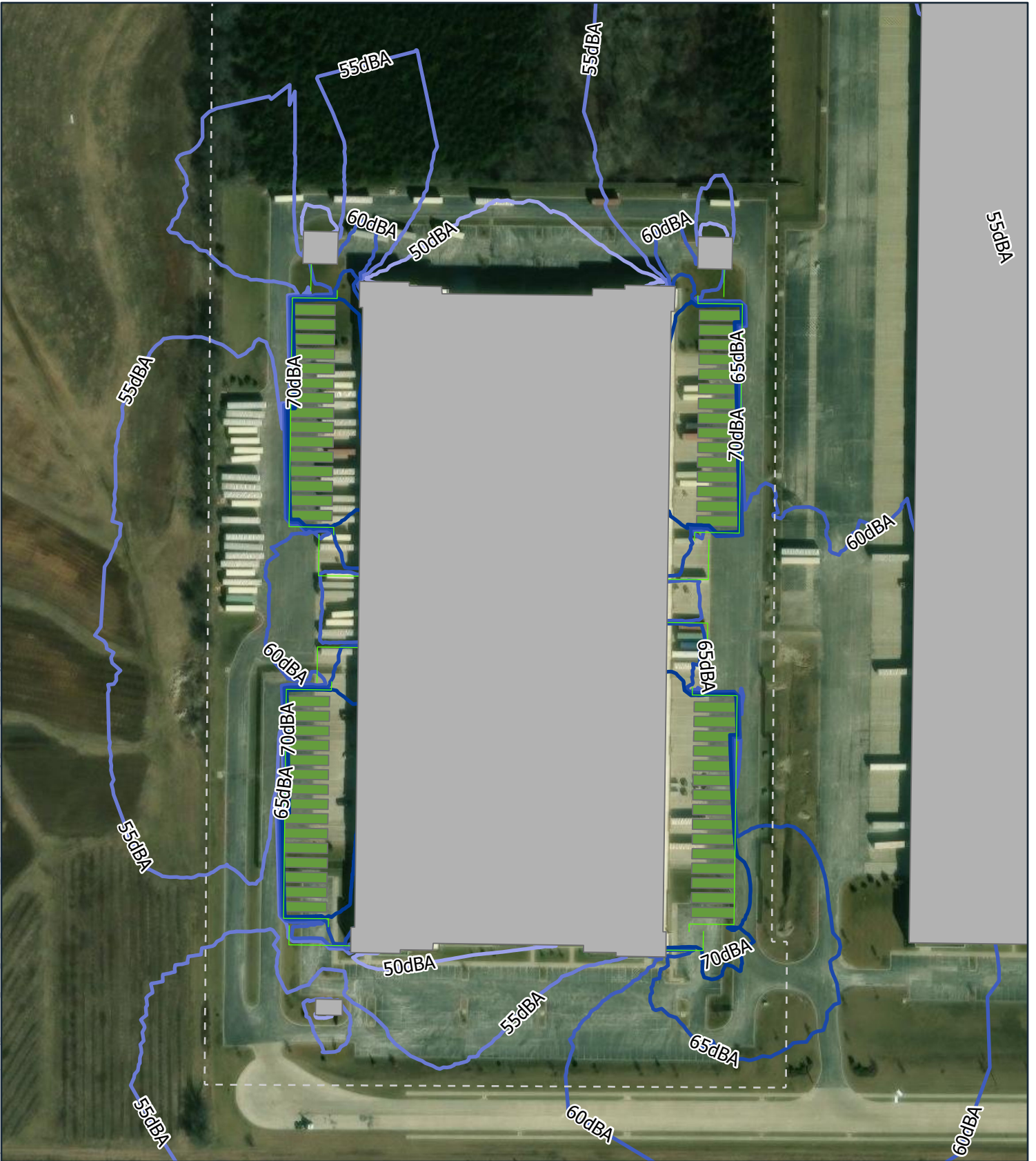

- - - Property Boundary

— Screening Walls

Modeled dBA - 4 SE
Units Testing

- 50
- 55
- 60
- 65
- 70

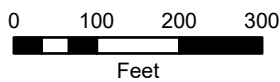

**Annual Generator Test
Chillers at Peak Summer
Cooling Demand - Detail**
Project Heartland
Edgerton, KS

FIGURE 6



June 2, 2026

Edgerton Planning Commission and City Staff
City of Edgerton
404 E. Nelson Street
Edgerton, Kansas 66021

Re: Final Site Plan FSP2026-0002, Data Center at 31800 W. 196th Street

Dear Members of the Planning Commission and City Staff,

We want to begin by acknowledging what we heard. The May 12 hearing made clear that this project raised real questions among members of the community and this Commission, and we do not take that lightly. Concerns about water, noise, and the arrival of a new neighbor are exactly the kinds of things a community should ask about. We heard those questions, and we made it our responsibility to answer: fully, in plain terms, and on the record.

Instead of pushing back, we went back to work. In the weeks since the hearing, we engaged independent engineers, gathered and documented the underlying data, and prepared the enclosed presentation so that every concern raised that evening has a clear, supported answer. Where an outside expert could speak to a question more credibly than we could, we brought one in, including a full noise screening analysis by Barr Engineering Co., enclosed with this letter.

It also helps to be clear about what this project is. This is not new industrial development taking up open space. We are adapting an existing 378,000-square-foot building, one that has stood in an established industrial park since 2016, in an area already home to logistics and industrial neighbors. In short, we are working with what is already here, not changing the character of the area.

With that context, here is the substance of what we found and what we have done:

- **The site.** The project adapts an existing building in an established industrial park. The exterior changes are limited, screened, and in keeping with the surroundings.
- **Water.** The cooling system is a sealed, closed loop, filled once with a mixture that is mostly water and then recirculated. It draws essentially no ongoing public water, discharges no cooling fluid, and is backed by automatic leak detection and multiple layers of containment sized to capture any incidental loss inside the building. The cooling fluid stays in the sealed loop, with no discharge and no pathway to Hillsdale Lake or the surrounding watershed.
- **Noise.** We retained Barr Engineering Co. to model the facility's sound using industry standards and best practices. At the nearest home, roughly 1,950 feet away, the modeling shows levels around 46 dBA, quieter than the Interstate 35 traffic already present, and still below 50 dBA even during the once-a-year, full-load generator test.
- **Air.** The backup generators exist only to keep the facility running during a power outage. They use clean, EPA Tier 2 engines on ultra-low-sulfur diesel, are permitted by the State below major-source thresholds, and sit idle nearly all of the year.

-
- **Equipment.** Because the servers hold sensitive data, retired hardware moves through a secure, documented chain of custody and is refurbished or recycled by certified handlers, deliberately kept out of the landfill while allowing adoption of new technologies to increase our efficiency and minimize waste.
 - **Community.** Beyond the construction and operating jobs the project brings, we are committed to local initiatives, including a proposed free coding and skills program, open to Edgerton residents of all ages, to leave a lasting benefit behind.

The fuller basis for each of these points is laid out in the enclosed presentation, and we welcome the chance to answer questions or otherwise elaborate.

We understand that trust is earned, not asserted. That is why our response rests on independent analysis, enforceable permits, and design choices we stand behind, including a voluntary commitment to conduct routine generator testing on a neighborly, weekday daytime schedule. We did not come to Edgerton to build something and walk away. We intend to be a genuine, long-term partner to this community, and we recognize that how we conduct ourselves now is the best evidence of that intention.

We hope this submission answers the questions of the Commission and staff as completely as you asked them. We appreciate your careful review and are available to you in advance of the June 9 meeting. Standing behind the foregoing principles, we respectfully ask for your support as the matter returns to you.

Respectfully,



Chelsea Kulhanek
Applicant's Representative
DAMAC Digital Solutions Kansas, LLC

Enclosures:

- Project Heartland — Response to the Planning Commission's May 12 Request
- Barr Engineering Co. — Project Heartland Noise Screening Analysis



ERM

8044 Montgomery Road
Suite 700 - 7736
Cincinnati, OH
45236

T +1 513 830 9030
F +1 513 830 9031

erm.com

Kansas Department of Health and Environment
Bureau of Air
1000 SW Jackson, Suite 310
Topeka, KS, 66612

DATE
8 May 2026

SUBJECT
CONFIDENTIAL AND NOT FOR DISTRIBUTION
Construction Permit Application for Edgerton Data
Center

REFERENCE
PN 823532

Dear Air Permitting Regulator:

DAMAC Digital Solutions Kansas LLC (DAMAC) intends to construct and operate a data center located at 31800 W. 196th Street, Edgerton, Kansas.

With this enclosed construction permit application (application), DAMAC is proposing to construct:

- 60 Caterpillar (CAT) 3516C diesel-fired emergency critical generators with engine model 3516C, each rated at 2,500 kilowatt-electric (kWe); and
- One CAT C32B diesel-fired emergency critical generator with engine model C32B rated at 1,500 kWe.

The potential NO_x emissions from the emergency generators will exceed the 40 tons per year (tpy) threshold specified in Kansas Administrative Regulations (KAR) 28-19-300(a)(1), thus requiring a construction permit for the generators. DAMAC is proposing an annual fuel consumption limit for the critical generators to limit NO_x emissions below the major source threshold of 100 tpy under a Class II operating permit. A Class II operating permit application will be submitted within one year of Facility startup.

Actual fuel usage will either be calculated based on actual generator operation data and manufacturer specifications or measured via fuel meters if installed on the generators. By complying with the proposed annual fuel consumption limit, nitrogen oxides (NO_x) will be limited to less than 100 tpy. Facility-wide emissions of other regulated pollutants will be limited to their corresponding Title V major source thresholds.

The enclosed application is provided in accordance with KAR 28-19-300(a)(1) to construct air emissions sources at the facility. DAMAC has included the following documentation:

- Appendix A: Application forms;
- Appendix B: Emissions calculations;
- Appendix C: Engine manufacturer specifications; and
- Appendix D: Facility site plan.



DATE
8 May 2026

REFERENCE
PN 823532

If you have any questions regarding this submittal or require additional information, please contact me at (513) 830-9062 or Abigail Pearse of Environmental Resources Management (ERM) at (610) 955-4042.

Sincerely,

Tiffany Cuni

Partner – ERM



**Kansas Department of Health and Environment
Division of Environment
Bureau of Air**

STATIONARY INTERNAL COMBUSTION ENGINES

- 1) Source ID Number: _____ CONFIDENTIAL AND NOT FOR DISTRIBUTION
- 2) Company/Source Name: _____
- 3) Type of Engine: Turbine _____ ; Reciprocating _____ ; Other _____
- 4) Engine Manufacturer: _____
Model No.: _____
Date of Manufacture: _____
Serial No.: _____
- 5) Use of Engine: Electric power generation ____; Compressor ____; Pump ____; Other - describe _____
- 6) Maximum Brake horsepower at continuous rating: _____ BHP
Normal operating engine speed: _____ RPM
Rated Brake Horsepower at normal operating RPM: _____ BHP
or
Maximum Generator Nameplate Capacity: _____ kW
Maximum design heat input rate: _____ BTU/hr
- 7) Operating schedule: _____ hrs per year
- 8) Date of Installation: _____
Date of Last modification: _____

TURBINES

- 9) Type of Gas Turbine: Simple cycle _____; Co-generation _____; Regenerative _____; Combined cycle _____
- 10) Fuel data for all the different types of fuel to be used:
a) Fuel Type _____; Sulfur content % by weight _____;
Lower heating value _____ BTU per cu ft; or _____ BTU per lb; or _____ BTU per gallon
b) Fuel Type _____; Sulfur content % by weight _____;
Lower heating value _____ BTU per cu ft; or _____ BTU per lb; or _____ BTU per gallon
c) Fuel Type _____; Sulfur content % by weight _____;
Lower heating value _____ BTU per cu ft; or _____ BTU per lb; or _____ BTU per gallon
- 11) Heat recovery unit or steam generator unit installed? Yes _____; No _____
Supplementary fired? Yes _____; No _____ If yes, type of fuel used: _____
Capacity of the burner _____ gals per hr
Fuel heating value _____ BTU per cu ft or gal
Sulfur content of fuel by weight _____ %; Please attach complete supplementary fuel oil/distillate analysis.

Stationary Internal Combustion Engines (Cont.)

- 12) Emission control system(s) used: Water injection _____; Steam injection _____;
 Selective Catalytic reduction with Water injection _____; Selective catalytic reduction _____;
 Describe Selective Catalytic emission reduction control installed: _____
 Manufacturer's name: _____ Model No.: _____

POLLUTANT	MANUFACTURER'S REDUCTION EFFICIENCY %

- 13) Did construction, modification, or reconstruction commence after October 3, 1977? Yes _____; No _____
 If yes, this facility may be subject to NSPS, 40 CFR 60, Subpart GG.

RECIPROCATING ENGINES

- 14) Engine design details:
 Number of cylinders _____
 Aspiration: Normal _____; Turbo charged _____
 Ignition: Spark _____; Compression _____
 Design class 2 cycle lean burn _____; 4 cycle lean burn _____; 4 cycle rich burn _____
- 15) 2 or 4 cycle lean burn with combustion modification, increased air/fuel ratio and intercooling?
 Yes _____; No _____
 If yes, attach the guaranteed performance of the conversion supplier **or** the actual monitored performance, and the engine operating conditions for the guarantee of performance.
- 16) Type of integral emission control: Selective Catalytic Reduction _____;
 Non Selective Catalytic Reduction _____; Combustion Reduction _____ (Describe) _____; None _____
- 17) Fuel(s): Gasoline _____; Diesel _____; Natural Gas _____; Dual fuel _____
- 18) Fuel Heating Value: Gasoline _____ BTU per gal; Diesel _____ BTU per gal;
 Natural Gas _____ BTU per cu ft; Dual fuel mix _____ % diesel _____ % natural gas
 Sulfur content of diesel by weight _____ %
- 19) Does the engine meet the definition of remote stationary RICE as specified in 40 CFR 63.6675?
 Yes _____; No _____
- 20) Does the engine meet the definition of a nonroad engine as specified in 40 CFR 1068.30?
 Yes _____; No _____

APPLICABLE TO ALL STATIONARY INTERNAL COMBUSTION ENGINES

- 21) Enclose available engine manufacturer's emissions data.
- 22) For emission control equipment, use the appropriate CONTROL EQUIPMENT form and duplicate as needed.
 Be sure to indicate the emission unit that the control equipment is affecting.



**Kansas Department of Health and Environment
Division of Environment
Bureau of Air**

STATIONARY INTERNAL COMBUSTION ENGINES

- 1) Source ID Number: GEN 61 CONFIDENTIAL AND NOT FOR DISTRIBUTION
- 2) Company/Source Name: DAMAC Digital Solutions Kansas LLC
- 3) Type of Engine: Turbine _____; Reciprocating X _____; Other _____
- 4) Engine Manufacturer: Caterpillar
Model No.: C32B
Date of Manufacture: 2026
Serial No.: _____
- 5) Use of Engine: Electric power generation ; Compressor ; Pump ; Other - describe _____
- 6) Maximum Brake horsepower at continuous rating: 2,218 BHP
Normal operating engine speed: 1,800 RPM
Rated Brake Horsepower at normal operating RPM: 2,218 BHP
or
Maximum Generator Nameplate Capacity: 1,500 kW
Maximum design heat input rate: _____ BTU/hr
- 7) Operating schedule: 500 hrs per year
- 8) Date of Installation: 12/2026
Date of Last modification: _____

TURBINES

- 9) Type of Gas Turbine: Simple cycle _____; Co-generation _____; Regenerative _____; Combined cycle _____
- 10) Fuel data for all the different types of fuel to be used:
a) Fuel Type _____; Sulfur content % by weight _____;
Lower heating value _____ BTU per cu ft; or _____ BTU per lb; or _____ BTU per gallon
b) Fuel Type _____; Sulfur content % by weight _____;
Lower heating value _____ BTU per cu ft; or _____ BTU per lb; or _____ BTU per gallon
c) Fuel Type _____; Sulfur content % by weight _____;
Lower heating value _____ BTU per cu ft; or _____ BTU per lb; or _____ BTU per gallon
- 11) Heat recovery unit or steam generator unit installed? Yes ; No
Supplementary fired? Yes ; No If yes, type of fuel used: _____
Capacity of the burner _____ gals per hr
Fuel heating value _____ BTU per cu ft or gal
Sulfur content of fuel by weight _____ %; Please attach complete supplementary fuel oil/distillate analysis.

Stationary Internal Combustion Engines (Cont.)

- 12) Emission control system(s) used: Water injection _____; Steam injection _____;
 Selective Catalytic reduction with Water injection _____; Selective catalytic reduction _____;
 Describe Selective Catalytic emission reduction control installed: _____
 Manufacturer's name: _____ Model No.: _____

POLLUTANT	MANUFACTURER'S REDUCTION EFFICIENCY %

- 13) Did construction, modification, or reconstruction commence after October 3, 1977? Yes ; No
 If yes, this facility may be subject to NSPS, 40 CFR 60, Subpart GG.

RECIPROCATING ENGINES

- 14) Engine design details:
 Number of cylinders 12
 Aspiration: Normal _____; Turbo charged X
 Ignition: Spark _____; Compression X
 Design class 2 cycle lean burn _____; 4 cycle lean burn X; 4 cycle rich burn _____
- 15) 2 or 4 cycle lean burn with combustion modification, increased air/fuel ratio and intercooling?
 Yes ; No
 If yes, attach the guaranteed performance of the conversion supplier **or** the actual monitored performance, and the engine operating conditions for the guarantee of performance.
- 16) Type of integral emission control: Selective Catalytic Reduction _____;
 Non Selective Catalytic Reduction _____; Combustion Reduction _____ (Describe) _____; None _____
- 17) Fuel(s): Gasoline _____; Diesel X; Natural Gas _____; Dual fuel _____
- 18) Fuel Heating Value: Gasoline _____ BTU per gal; Diesel 138,000 BTU per gal;
 Natural Gas _____ BTU per cu ft; Dual fuel mix _____ % diesel _____ % natural gas
 Sulfur content of diesel by weight 0.0015 %
- 19) Does the engine meet the definition of remote stationary RICE as specified in 40 CFR 63.6675?
 Yes ; No
- 20) Does the engine meet the definition of a nonroad engine as specified in 40 CFR 1068.30?
 Yes ; No

APPLICABLE TO ALL STATIONARY INTERNAL COMBUSTION ENGINES

- 21) Enclose available engine manufacturer's emissions data.
- 22) For emission control equipment, use the appropriate CONTROL EQUIPMENT form and duplicate as needed.
 Be sure to indicate the emission unit that the control equipment is affecting.



CONFIDENTIAL AND NOT FOR DISTRIBUTION

Equipment included in the preliminary per unit offering is limited to the following Caterpillar 3516C-HD, 2500kW Mission Critical Standby* generator configuration:

- 2500kW electrical capacity, 60 Hz, 480VAC
 - Caterpillar SR5, 1670 Generator Frame, arrangement number 5493798
 - 2500kW / 3125kVA rating at 0.8 PF
 - 125C Temp Rise over 40C Ambient
 - Permanent magnet excitation
 - Alternator Space Heater
 - Alternator RTD's w/ generator temperature monitoring capability
 - Caterpillar ECS 200 Control Panel
 - Remote Annunciator (quantity 1)
 - Caterpillar ADEM A6 Engine Governor
 - Caterpillar Digital Voltage Regulator
 - Ethernet Communications utilizing Modbus TCP/IP protocol

Engine Accessories include:

- Caterpillar cooling system with 113F ambient temperature capability and engine driven radiator fan
- Caterpillar heavy duty dual-element engine air filter
- Dual electric engine starters
- Jacketwater heater
- Engine coolant
- Engine oil
- Seismic vibration isolators

Electrical accessories include:

- Rear-mounted, Masterpact 4000 Amp, 3-pole, electrically operated circuit breaker with LSIG-P electronic trip unit.
- Bottom Cable Entry

Additional listings, certifications and test reports included with configuration:

- UL2200 listing
- Caterpillar seismic certification
- Alternator Test Report
- Standard Engine Test Report
- Standard Torsional Vibration Analysis Report
- Generator Package Test Report @ 0.8 PF (manufacturer's standard production test)**

* Caterpillar's Mission Critical Standby rating can be used in Uptime Institute Tier III and Tier IV topologies, meeting the functional intent of the "Data Center Continuous" requirements identified in the specifications. Caterpillar does not offer a product solution that carries a "Data Center Continuous" rating.

** Manufacturer's unit test's do not comply in total with specified FAT test procedures. Provisions to support additional test requirements identified in the FAT specifications will require further review in order to provide a commercial response.

The proposed generator selection meets the functional requirements of the following sections of the Kansas City LV Generators Specification: 4.1.1, 4.1.2, 4.1.3, 4.1.4, 4.1.5, 4.1.10, 4.1.13, 4.1.14, 4.1.15 (engine starters only), 4.1.16, 4.1.17, 4.1.18, 4.1.19, and 4.1.20 as further detailed in the attached manufacturer's specification sheets and associated technical documentation. Please note that the pricing information is predicated on the manufacturer's standard solution(s) and the associated published performance characteristics. In the event there is a deviation between any of the manufacturer's published performance data and the specified performance characteristics, the manufacturer's data will take precedent. At this time, no monies have been allocated to otherwise upfit, modify or adjust the manufacturer's standard offering to ensure full compliance with the performance requirements as specified.

Please note that there are several sections within the referenced specifications which require additional clarification and/or discussion to ensure any potential solution will meet the operating and performance requirements for the facility. As such, the proposed offering explicitly excludes any provisions associated with the following sections of the Kansas City LV Generators Specification:

- 2.2 Outdoor Generator Set Enclosure
- 2.3 Environmental Conditions (as related to noise, exhaust and intake considerations)
- 3.0 Tender Return Requirements
- 4.1.6 Battery Charger
- 4.1.7 Batteries
- 4.1.8 Battery Trays
- 4.1.9 Fuel system (as related to duplex filtration request)
- 4.1.11 Crankcase Ventilation System
- 4.1.12 Engine Exhaust System
- 4.1.15 Starting System (as related to battery performance)
- 4.1.21 Generator Output Switchboard
- 4.1.22 Diesel Base Tank
- 4.1.23 Wiring and Conduit
- 4.1.24 Equipment Communication Interface to BMS
- 4.1.25 Communication Interface Architecture Guidelines
- 4.2 Mounting and foundations (as related to vibration transmission requirements)
- 4.3 Generator Acoustic System (pending clarification of enclosure requirements)
- 4.4 Exhaust System (pending clarification of enclosure requirements)
- 4.4.3 Belly Tanks (pending clarification of enclosure requirements)
- 4.5 Factory Testing
- 5.1 Delivery on Site
- 5.2 Final Positioning
- 5.3 BMS and Controls Accessories
- 5.4 Warranty

Additionally, please note that the initial offer does not include any freight, taxes, startup, commissioning or other related field services which may be required to deliver the equipment to the job site or place the equipment in service. The current offering is **only** indicative of the at-risk expenditures associated with order placement as required to ensure equipment deliveries in the desired timeframe.

Foley acknowledges that additional effort will be required to define and develop the remaining scope items and will work, within reason, to ensure any open items are resolved, with subsequent pricing impacts developed in a timely manner as required to support project schedules.

Cat® 3516C

Diesel Generator Sets



Image shown may not reflect actual configuration

Bore – mm (in)	170 (6.69)
Stroke – mm (in)	215 (8.46)
Displacement – L (in ³)	78.1 (4766)
Compression Ratio	14.7:1
Aspiration	TA
Fuel System	EUI
Governor Type	A6E4

Standby 60 Hz ekW (kVA)	Mission Critical 60 Hz ekW (kVA)	Prime 60 Hz ekW (kVA)	Continuous 60 Hz ekW (kVA)	Emissions Performance
2500 (3125)	2500 (3125)	2250 (2812)	2050 (2562)	U.S. EPA Stationary Emergency Use Only (Tier 2)

Features

Cat® Diesel Engine

- Meets U.S. EPA Stationary Emergency Use Only (Tier 2) emission standards
- Reliable performance proven in thousands of applications worldwide
- Certified alternative fuels including Hydrotreated Vegetable Oil (HVO), Renewable Diesel (RD) and Hydrotreated Renewable Diesel (HRD) which meet EN 15940 or ASTM D975 can be used or blended with EN 590 diesel

Generator Set Package

- Accepts 100% block load in one step
- Meets NFPA 110 loading requirements
- Conforms to ISO 8528-5 G3 load acceptance requirements
- Reliability verified through torsional vibration, fuel consumption, oil consumption, transient performance, and endurance testing

Alternators

- Superior motor starting capability minimizes need for oversizing generator
- Designed to match performance and output characteristics of Cat diesel engines

Cooling System

- Cooling systems available to operate in ambient temperatures up to 50°C (122°F)
- Tested to ensure proper generator set cooling

Cat Energy Control System (ECS)

- User-friendly interface and navigation
- Scalable system to meet a wide range of installation requirements
- Expansion modules and site specific programming for specific customer requirements
- Graphical touchscreen display
- Easily upgradeable

Warranty

- 24 months/1000-hour warranty for standby and mission critical ratings
- 12 months/unlimited hour warranty for prime and continuous ratings
- Extended service protection is available to provide extended coverage options

Worldwide Product Support

- Cat dealers have over 1,800 dealer branch stores operating in 200 countries
- Your local Cat dealer provides extensive post-sale support, including maintenance and repair agreements

Financing

- Caterpillar offers an array of financial products to help you succeed through financial service excellence
- Options include loans, finance lease, operating lease, working capital, and revolving line of credit
- Contact your local Cat dealer for availability in your region

Standard and Optional Equipment

Engine

Air Cleaner

- Single element
- Dual element

Muffler

- Industrial grade (15 dB)

Starting

- Standard batteries
- Oversized batteries
- Standard electric starter(s)
- Heavy duty electric starter(s)
- Air starter(s)
- Jacket water heater

Alternator

Output voltage

- 380V 6300V
- 440V 6600V
- 480V 6900V
- 600V 12470V
- 2400V 13200V
- 4160V 13800V

Temperature Rise (over 40°C ambient)

- 150°C
- 125°C/130°C
- 105°C
- 80°C

Winding type

- Random wound
- Form wound

Excitation

- Internal excitation (IE)
- Permanent magnet (PM)

Attachments

- Anti-condensation heater
- Stator and bearing temperature monitoring and protection

Power Termination

Type

- Bus bar
- Circuit breaker
- 1600A 2000A
- 2500A 3000A
- 3200A 4000A
- 5000A
- IEC UL
- 3-pole 4-pole
- Manually operated
- Electrically operated

Trip Unit

- LSI LSI-G
- LSI-G-P

Control System

Controller

- Cat ECS 100
- Cat ECS 200
- EMCP 4.4

Attachments

- Local annunciator module
- Remote annunciator module
- Expansion I/O module
- Remote monitoring software

Charging

- Battery charger – 10A
- Battery charger – 20A
- Battery charger – 35A

Vibration Isolators

- Rubber
- Spring
- Seismic rated

Cat Connect

Connectivity

- Ethernet
- Cellular

Extended Service Options

Terms

- 2 year (prime)
- 3 year
- 5 year
- 10 year

Coverage

- Silver
- Gold
- Platinum
- Platinum Plus

Ancillary Equipment

- Automatic transfer switch (ATS)
- Paralleling switchgear
- Paralleling controls

Certifications

- ULC 2200 Listed
- IBC seismic certification
- OSHPD pre-approval

Note: Some options may not be available on all models. Certifications may not be available with all model configurations. Consult factory for availability.

Package Performance

Performance	Standby	Mission Critical	Prime	Continuous
Frequency	60 Hz	60 Hz	60 Hz	60 Hz
Gen set power rating with fan	2500 ekW	2500 ekW	2250 ekW	2050 ekW
Gen set power rating with fan @ 0.8 power factor	3125 kVA	3125 kVA	2812 kVA	2562 kVA
Emissions	EPA ESE (TIER 2)	EPA ESE (TIER 2)	EPA ESE (TIER 2)	EPA ESE (TIER 2)
Performance number	EM6670-00	EM6671-01	EM6674-01	EM6676-01
Fuel Consumption				
100% load with fan – L/hr (gal/hr)	636.0 (168.0)	636.0 (168.0)	574.1 (151.7)	531.9 (140.5)
75% load with fan – L/hr (gal/hr)	494.6 (130.7)	494.6 (130.7)	453.0 (119.7)	421.7 (111.4)
50% load with fan – L/hr (gal/hr)	360.5 (95.2)	360.5 (95.2)	331.0 (87.5)	306.7 (81.0)
25% load with fan – L/hr (gal/hr)	212.3 (56.1)	212.3 (56.1)	196.6 (51.9)	182.9 (48.3)
Cooling System				
Radiator air flow restriction (system) – kPa (in. water)	0.12 (0.48)	0.12 (0.48)	0.12 (0.48)	0.12 (0.48)
Radiator air flow – m ³ /min (cfm)	2356 (83201)	2356 (83201)	2356 (83201)	2356 (83201)
Engine coolant capacity – L (gal)	233.0 (61.6)	233.0 (61.6)	233.0 (61.6)	233.0 (61.6)
Radiator coolant capacity – L (gal)	180.0 (47.6)	180.0 (47.6)	180.0 (47.6)	180.0 (47.6)
Total coolant capacity – L (gal)	413.0 (109.2)	413.0 (109.2)	413.0 (109.2)	413.0 (109.2)
Inlet Air				
Combustion air inlet flow rate – m ³ /min (cfm)	202.0 (7133.1)	202.0 (7133.1)	191.0 (6745.1)	182.2 (6433.4)
Exhaust System				
Exhaust stack gas temperature – °C (°F)	456.2 (853.1)	456.2 (853.1)	439.9 (823.8)	433.9 (813.0)
Exhaust gas flow rate – m ³ /min (cfm)	523.8 (18497.4)	523.8 (18497.4)	481.3 (16994.8)	452.7 (15984.0)
Exhaust system backpressure (maximum allowable) – kPa (in. water)	6.7 (27.0)	6.7 (27.0)	6.7 (27.0)	6.7 (27.0)
Heat Rejection				
Heat rejection to jacket water – kW (Btu/min)	826 (46992)	826 (46992)	777 (44160)	739 (42021)
Heat rejection to exhaust (total) – kW (Btu/min)	2502 (142265)	2502 (142265)	2243 (127532)	2092 (118949)
Heat rejection to aftercooler – kW (Btu/min)	786 (44723)	786 (44723)	690 (39224)	619 (35176)
Heat rejection to atmosphere from engine – kW (Btu/min)	161 (9146)	161 (9146)	150 (8542)	145 (8229)
Heat rejection from alternator – kW (Btu/min)	121 (6853)	121 (6853)	99 (5607)	94 (5368)
Emissions* (Nominal)				
NOx mg/Nm ³ (g/hp-h)	2349.1 (5.32)	2349.1 (5.32)	2206.7 (4.95)	2038.1 (4.62)
CO mg/Nm ³ (g/hp-h)	195.4 (0.42)	195.4 (0.42)	141.2 (0.30)	124.8 (0.27)
HC mg/Nm ³ (g/hp-h)	42.1 (0.10)	42.1 (0.10)	44.4 (0.11)	49.2 (0.12)
PM mg/Nm ³ (g/hp-h)	14.1 (0.04)	14.1 (0.04)	10.9 (0.03)	11.0 (0.03)
Emissions* (Potential Site Variation)				
NOx mg/Nm ³ (g/hp-h)	2818.9 (6.38)	2818.9 (6.38)	2648.0 (5.94)	2445.8 (5.55)
CO mg/Nm ³ (g/hp-h)	351.8 (0.76)	351.8 (0.76)	254.2 (0.55)	224.6 (0.49)
HC mg/Nm ³ (g/hp-h)	55.9 (0.14)	55.9 (0.14)	59.1 (0.15)	65.5 (0.16)
PM mg/Nm ³ (g/hp-h)	19.7 (0.05)	19.7 (0.05)	15.2 (0.04)	15.3 (0.04)

*mg/Nm³ levels are corrected to 5% O₂. Contact your local Cat dealer for further information.

Weights and Dimensions

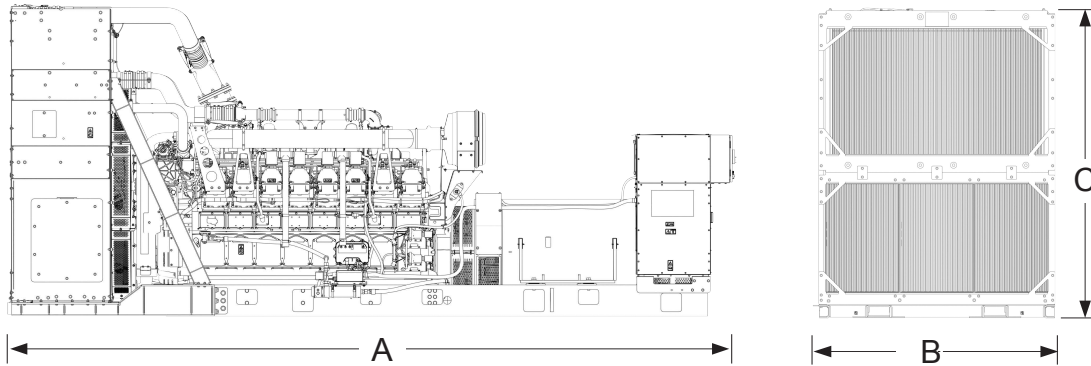

Dim "A" mm (in)	Dim "B" mm (in)	Dim "C" mm (in)	Dry Weight kg (lb)
7019 (276.3)	2339 (92.1)	2997 (118.0)	17 590 (38,780)

Note: For reference only. Do not use for installation design.
Contact your local Cat dealer for precise weights and dimensions.

Ratings Definitions

Standby

Output available with varying load for the duration of the interruption of the normal source power. Average power output is 70% of the standby rated kW. Typical operation is 200 hours per year, with maximum expected usage of 500 hours per year.

Mission Critical

Output available with varying load for the duration of the interruption of the normal source power. Average power output is 85% of the mission critical rated kW. Typical peak demand up to 100% of rated kW for up to 5% of the operating time. Typical operation is 200 hours per year, with maximum expected usage of 500 hours per year.

Prime

Output available with varying load for an unlimited time. Average power output is 70% of the prime rated kW. Typical peak demand is 100% of prime rated kW with 10% overload capability for emergency use for a maximum of 1 hour in 12. Overload operation cannot exceed 25 hours per year.

Continuous

Output available with non-varying load for an unlimited time. Average power output is 70-100% of the continuous rated kW. Typical peak demand is 100% of continuous rated kW for 100% of the operating hours.

Applicable Codes and Standards

AS 1359, ULC 2200 3rd edition, UL 489, UL 869A, IBC, IEC 60034-1, ISO 3046, ISO 8528, NEMA MG1-22, NEMA MG1-33, 2014/35/EU, 2006/42/EC, 2014/30/EU and facilitates compliance to NFPA 37, NFPA 70, NFPA 99, NFPA 110.

Note: Codes may not be available in all model configurations. Please consult your local Cat dealer for availability.

Data Center Applications

- All ratings Tier III/Tier IV compliant per Uptime Institute requirements.
- All ratings ANSI/TIA-942 compliant for Rated-1 through Rated-4 data centers.

Fuel Rates

Fuel consumption reported in accordance with ISO 3046-1, based on fuel oil of 35° API [16°C (60°F)] gravity having an LHV of 42,780 kJ/kg (18,390 Btu/lb) when used at 15°C (59°F) and weighing 850 g/liter (7.0936 lbs/U.S. gal.) All fuel consumption values refer to rated engine power.

www.cat.com/electricpower
©2025 Caterpillar
All rights reserved.

Materials and specifications are subject to change without notice.
The International System of Units (SI) is used in this publication.

CAT, CATERPILLAR, LET'S DO THE WORK, their respective logos, "Caterpillar Corporate Yellow", the "Power Edge" and Cat "Modern Hex" trade dress as well as corporate and product identity used herein, are trademarks of Caterpillar and may not be used without permission.



Image Shown may not Reflect Actual Package.

SR5 — 1600 Frame

Standby Power

50 Hz, 1500 rpm 1440 – 2750 kVA
 60 Hz, 1800 rpm 1320 – 2600 ekW

Prime Power

50 Hz, 1500 rpm 1440 – 2500 kVA
 60 Hz, 1800 rpm 1320 – 2250 ekW

Continuous Power

50 Hz, 1500 rpm 1440 – 2000 kVA
 60 Hz, 1800 rpm 1320 – 2250 ekW

Features

General

- Standards: meets the requirements of NEMA,
- IEC, ISO, IEEE, BS, AS
- Industry leading insulation technology
- Proven mechanical and electrical design
- Reliable and durable construction
- Improved excitation system for high power quality
- Improved motor starting capability
- Radio frequency noise suppression better than industry standards
- Superior construction and testing

Standard

- 3 Phase brushless, salient pole
- NEMA Class H insulation
- Class H Temperature rise at 40°C ambient
- 2/3 Winding pitch
- Low voltage: Random Wound and Internal Excitation
- Medium voltage: Form Wound and Permanent Magnet
- Standard voltages:
 - 60 Hz: 480V, 4160V
 - 50 Hz: 400V, 3300V
- Busbar connections:
 - 60 Hz models: NEMA standard hole pattern
 - 50 Hz models: EC standard hole pattern
- Cat® Digital Voltage Regulator (Cat DVR)

Optional

- PM excitation capability to IE excitation
- Low Voltage: Form Wound
- Space heater kit
- Bearing temperature detectors
- Optional voltages:
 - 60 Hz: 380V, 440V, 600V, 2400V
 - 50 Hz: 380V, 415V
- Oversized generators for Class F or Class B temperature rise
- UL Listing
- CSA test and certification

NEMA MG-1 Temperature Rise (Over 40°C ambient)

	Class A	Class B	Class F	Class H
Standby	85°C	105°C	130°C	150°C
Prime / Continuous	60°C	80°C	105°C	125°C

Specifications

Type

Brushless, revolving field solid-state automatic voltage regulator

Construction

One bearing 3 phase, series star connected

Enclosure

Drip proof IP23, guarded

Alignment

Cat pilot shaft, single bearing only

Over-speed capability

60 Hz — 125% of synchronous speed

50 Hz — 150% of synchronous speed

Waveform deviation, line to line, no load

Less than 2%

Paralleling capability

Standard with adjustable voltage droop

Voltage level adjustment

+/- 5%

Voltage regulator

3 Phase sensing with variable Volts-Per Hertz response

Voltage regulation, steady state

+/- 0.5%

Voltage regulation with 3% speed change

+/- 0.5%

Voltage gain

Adjustable to compensate for engine speed droop and line loss

TIF Less than 50

Number of leads 6

Product Support

- Standard Caterpillar warranty
- Optional extended Caterpillar warranty
- Serviceable parts available through Caterpillar Parts System
- Service intervals agree with recommended engine practices

Serviceability

- Stator leads exit top
- Replaceable bearing sleeve(s) for longer life and lower repair cost
- Easy access to serviceable parts
- Improved wire and terminal identification ensuring reliable connection

Cable Entry

- Top cable entry on LV package
- Bottom cable entry on MV packages

Information contained in this publication may be considered confidential. Discretion is recommended when distributing. Materials and specifications are subject to change without notice.

CAT, CATERPILLAR, LET'S DO THE WORK, their respective logos, "Caterpillar Corporate Yellow", the "Power Edge" and Cat "Modern Hex" trade dress as well as corporate and product identity used herein, are trademarks of Caterpillar and may not be used without permission.

Main Stator Construction

The 1600 frame generators use Round lamination stator design.

Stator coil pitch, coil distribution designed to produce optimum waveform and minimum total harmonic distortion. Stator slots are insulated by slot liners and coil separators. Slot liners, coil separators, and top sticks provide a minimum of 25 mm (1 in) distance from the coil to ground. The thickness of liners, separators, and phase sheets provides superior protection between phases and ground.

Low voltage stator windings are given a 3000 volt "high pot" test (150% of the NEMA and IEC requirements for 460 volt generators) before the insulation is applied.

The stators are then given a vacuum impregnation treatment of polyester material, followed by an application of epoxy resin. This sealed stator is then given a final 2000 volt "high pot" test.

Rotor Construction

The main rotor is constructed using a precision "wet" layer winding process with epoxy painted on the bare rotor and on each layer. This ensures bonding of all the wire layers together, bonding of the coils to the rotor laminations, and a sealed insulation system. The rotor is put in the oven for curing the epoxy.

The exciter rotor is machine wound and receives a trickle coat of a fungus-resisting resin. Numerically controlled turning and grinding machines produce rotor shafts with close repeatable tolerances. Grade-8 bolts are used wherever joints are subject to induced stresses. A complete coating of red sealer is applied to protect the rotors and shaft from corrosion.

Every production rotor is dynamically balanced in two planes to within 0.0508 mm deflection peak-to-peak amplitude and run at rated speed before assembly into the stator.



Picture shown may not reflect actual configuration

A6E4 Engine Controller

The A6E4 is the main Electronic Control Module (ECM) used on select diesel engines. This engine control module has been developed around high performance multi-core architecture to offer a configurable and rugged control unit. The A6E4 is designed to control/interface Electronic Unit Injector (EUI) equipped engines and provides a high degree of control over a large number of combustion variables. The A6E4 engine system is composed of the A6E4 ECM, control software, sensors, actuators, fuel injectors, and interface to the generator system. The prime benefit of an A6E4 engine system is to better control and maintain the particulate emissions, both steady state and transient, while improving engine performance.

FEATURES

RELIABLE AND DURABLE

- All A6E4 controllers are designed to survive the harshest environments.
- Environmentally sealed, die-cast aluminum housing isolates and protects electronic components from moisture and dirt contamination.
- Rigorous vibration testing ensures product reliability and durability.
- Programmable dither period and amplitude
- Configurable current control
- NVSRAM Support
- Rated IP67 against water and dust
- 4-20mA Current Input and output capability.
- Accuracy maintained from -40°C to 85°C
- Internal circuits are designed to withstand shorts to +battery and -battery.
- Built-in fault detection and diagnostics
- Supports J1939 (CAN), CDL, and IEEE 802.3 (Ethernet) data links
- Tested to SAE standards (J1455, J113, ISO 11452, ISO 7637, ISO 13766, IEC 60529, IEC 60533)

SIMPLE SERVICING

- Each A6E4 system works in combination with the Cat[®] ET service tool software to keep the engine operating at peak performance.
- Displays measured parameters
- Retrieves active and logged event code documenting abnormal system operation
- Performs calibrations and diagnostic tests
- Supports flash programming of new software into the A6E4 ECM

SELF DIAGNOSTICS

- Each A6E4 ECM has a full complement of diagnostics. The ECM can detect faults in the electrical system and report those faults to the service technician for quick repair.
- Self-diagnostic capability pinpoints operational problems in need of attention.

ADVANCED FEATURES

- Enhanced performance from fuel injection timing and limiting
- Adjustable monitoring of vital engine parameters
- Programmable speed acceleration ramp rate
- Data link interfaces

DESCRIPTION

The ECM is housed in an environmentally sealed casting. All wiring connections to the ECM are made using three sealed connectors: a single seventy pin connector, a single one-hundred twenty pin connector and a two-pin Ethernet connector.

ENGINE SPEED GOVERNING

Desired engine speed is calculated by the ECM and held within ± 0.2 Hz for isochronous and droop mode. The ECM accounts for droop that is requested. The proper amount of fuel is sent to the injectors due to these calculations.

The ECM also employs cool down/shutdown strategies, acceleration delays on startup, acceleration ramp times and speed reference.

FUEL LIMITING

Warm and cold fuel-air ratio control limits are controlled by the ECM.

Electronic monitoring system derates, torque limit, and cranking limit, programmable torque scaling, and cold cylinder cutout mode are standard features.

FUEL INJECTION TIMING

Master timing for injection is controlled by the ECM control.

Temperature dependencies are accounted for in the fuel injection calculations.

ELECTRONIC MONITORING

Electronic monitoring of vital engine parameters can be programmed.

Warning, derate, and shutdown event conditions may be customized by the user.

INFORMATION MANAGEMENT

The ECM stores information to assist with electronic troubleshooting.

Active and logged diagnostic codes, active events, logged events, fuel consumption, engine hours, and instantaneous totals aid service technicians when diagnosing electronic faults and scheduling preventive maintenance.

CALIBRATIONS

Engine performance is optimized through injection timing.

Auto/manual sensor calibrations are standard features.

ON-BOARD SYSTEM TESTS

System tests are available to assist in electronic troubleshooting.

These tests include: injector activation, injector cutout, and override of control outputs.

DATA LINK INTERFACES

The A6E4 communicates with the Cat ECS or EMCP via a dedicated communication network.

ELECTRONIC SENSING

The following sensing is available on the A6E4: oil pressure, fuel pressure, fuel temperature, atmospheric pressure, air inlet temperature, turbo outlet pressure, engine coolant temperature, engine speed, throttle, position, exhaust temperature, oil filter pressure differential, fuel filter pressure differential, air filter pressure differential and crankcase pressure.

SPECIFICATIONS

- Housing: Die-cast aluminum
- Impervious to: salt spray, fuel, oil and oil additives, coolant, spray cleaners, and dust
- Input and output protection: all inputs and outputs are protected against short circuits to +battery and -battery
- 12 and 24V input voltage support
- 24VDC nominal: 18 to 32 VDC
- 12VDC nominal: 9 to 16 VDC
- Mounting - engine mounted
- Reverse polarity protected
- Vibration (shock isolated components tolerance): $8G_{rms}$ random vibration from 24-2000 Hz in three orthogonal planes
- Temperature range (Maximum thermal limit may vary by application):
 - Operating: -40°C to $+85^{\circ}\text{C}$ (-40°F to $+185^{\circ}\text{F}$)
 - Storage: -55°C to $+135^{\circ}\text{C}$ (-67°F to $+275^{\circ}\text{F}$)
- Maximum Average Operating Current (Load Specific) $45A_{rms}$

PROCESSING ELEMENTS

- Microprocessor: MPC5777C
- Processor Speed: 256 MHz
- FPGA: MGL025
- Flash ROM: 8 MB
- SRAM – internal: 512 KB
- SRAM – external: 512 KB
- Non-volatile RAM (NVS RAM): 512KB
- ADC: 12 bit

GENERAL DRAWING

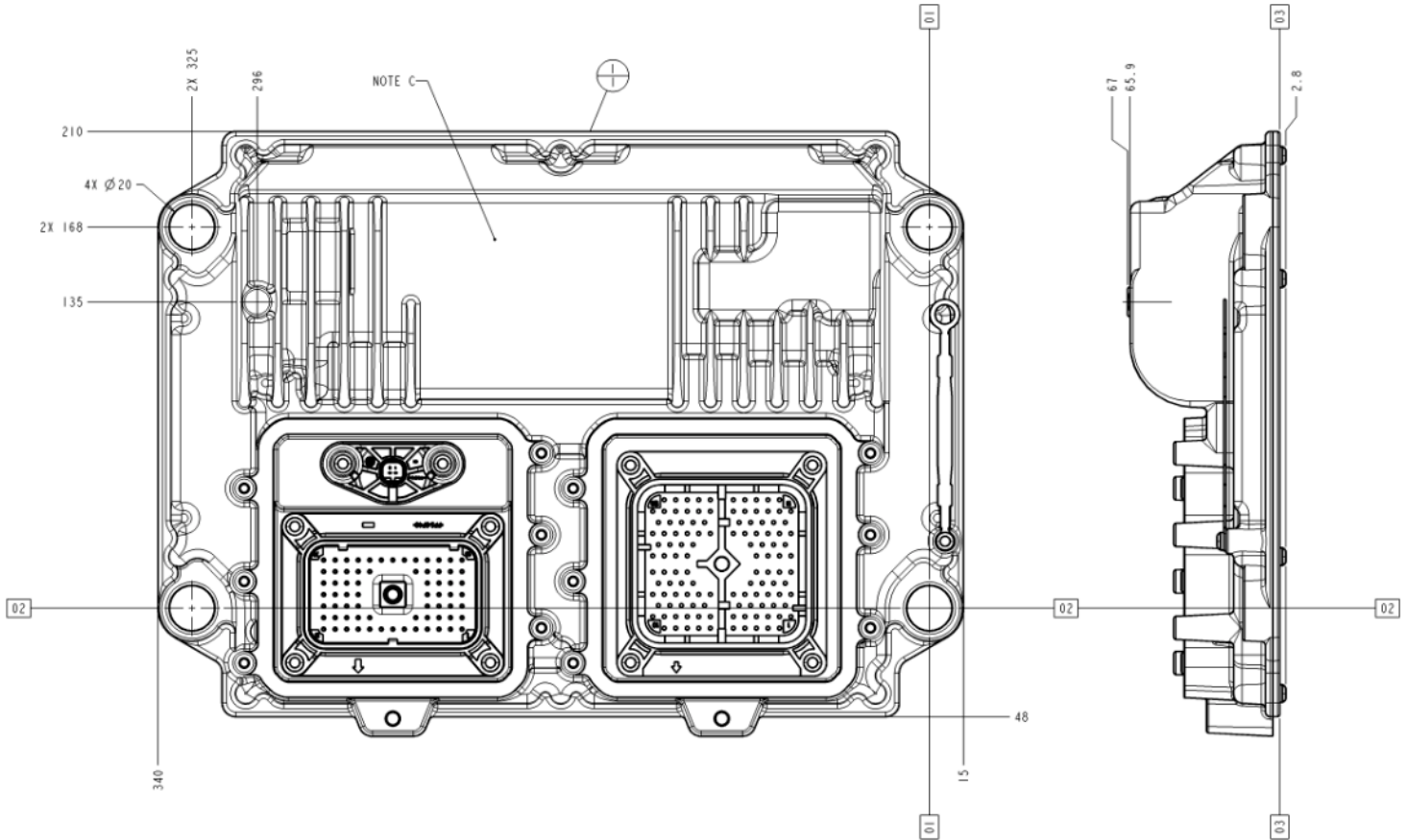

Length: 355 mm (14.0")
 Height: 265mm (10.4")
 Width: 69.8 mm (2.7")
 Weight: 3.85 kg (8.49 lb)

Materials and specifications are subject to change without notice.
 CAT, CATERPILLAR, LET'S DO THE WORK, their respective logos, "Caterpillar Corporate Yellow", the "Power Edge" and Cat "Modern Hex" trade dress as well as corporate and product identity used herein, are trademarks of Caterpillar and may not be used without permission.



Picture shown may not reflect actual configuration

Features

- Microprocessor based control featuring choice of three control modes standard:
 - Automatic Voltage Regulation (AVR)
 - Power Factor Regulation (PF)
 - Reactive Power Regulation (Var)
- Programmable stability settings
- Soft start control with an adjustable time setting in AVR control mode
- Dual Slope Underfrequency (volts/hertz) regulation
- Three-phase or single-phase generator voltage
- (RMS) sensing/regulation in AVR mode
- Single-phase generator current sensing for regulation purposes
 - Field current and field voltage sensing
 - Five contact sensing inputs for system interface
- One common LED for visual indication of Alarm and Shutdown fault conditions
 - Fault Shutdown Driver and Alarm Output Driver for indication of Alarm and Shutdown fault conditions
- Generator paralleling with reactive droop compensation and reactive differential compensation
- Line drop compensation
- Remote communication interface via CAN 2.0B
- Ten generator protective functions
- UL 6200 Recognized and CE certified

Digital Voltage Regulator

The Cat® Digital Voltage Regulator is a microprocessor based control designed to provide precise voltage control, robust transient response, and generator protection with industry leading features and versatility.

Worldwide Product Support

- Worldwide parts availability through the Cat dealer network.
- Over 1,800 dealer branch stores operating in 166 countries.
- 99.7% of parts orders filled within 24 hours. The best product support record in the industry.
- Cat dealer service technicians are trained to service every aspect of your electric power generation system.



Complete System Integration

Fully designed and factory tested to work seamlessly with Cat Generator using Shunt, PMG, or AREP excitation systems and EMCP controls.

Specifications

General Specifications	
Voltage Regulation	±0.25% no load to full load
Temperature Drift	±1.0% for a 40° C change
Response Time	Maximum of 10 milliseconds
Variable Sensing Range	90 to 600 Volts
Control Power	24 Vdc Supply (18 to 30 Vdc, 5VA)
Regulator Filtering	THF 3% per IEC34-1 TIF of 50 NEMA MG1-22.43
Harmonic Tolerance	0.5% Voltage regulation with 40% THD
Weight	1.47 kg (3.25 lb)
Environmental	
Operating Temperature	-40° C to 70° C (-40° F to 158° F)
Storage Temperature	-40° C to 85° C (-40° F to 185° F)
Relative Humidity	95% non-condensing 30° C to 60° C
Salt Spray	5% for 48 hrs at 38° C at 115% nominal operating voltage
Vibration	4.5G (peak) 18-2000 Hz in 3 perpendicular planes
Shock	20G
Certifications	
CE Approved	
UL Recognized	
CSA Listed	

Protective Functions

- Generator Overvoltage
- Generator Undervoltage
- Loss of Excitation
- Instantaneous Field Overcurrent
- Over Excitation
- Loss of Sensing
- Diode Fault Monitor
- Internal Watchdog Failure
- Internal Memory Failure
- Fault Reset Closed Too Long

Programmable Variables	Range of Adjustment
Voltage vs Frequency Characteristic	Two slope ranges adjustable from 1 to 10 PU in 0.1 increments
Fine Voltage Level	-10% to +10% in 0.1% increment
Droop Adjustment	0 to 10% in 0.1% increment
Overvoltage Setpoint	105 to 135% of rated voltage in 1.0% increment
Overvoltage Time Delay	2 to 30 seconds in 1 second increments
Undervoltage Setpoint	60 to 95% of rated voltage in 1.0% increment
Undervoltage Time Delay	10 to 120 seconds in 1 second increments
Gain	1 to 20% in 0.1% increments
Single Phase or Three Phase Sensing	
Under Frequency Point	20 to 40 Hz
Knee Frequency	45 to 65 Hz in 0.1 Hz increments
Minimum Voltage Setpoint	50 to 100% of rated voltage
Var Operating Mode	100% to -100% in 0.001 increments
PF Operating Mode	0.6 lead to 0.6 lag in 0.01 increments
Line Drop (IR) Compensation	0 to 10% in 0.1% increment
Loss of Excitation	0.1 to 1.0 PU leading vars
Loss of Excitation Time Delay	0.1 to 9.9 seconds in 0.1 second increments
Over Excitation	0 to 12 Adc in 0.1 Adc increments
Time Delay — Fixed Time Option	0 to 10 sec in 0.1 sec increments
Loss of Sensing Time Delay	0 to 25 sec in 1 sec increments
Diode Fault Monitor	1 to 10A rms field ripple current
Soft Start Function	1 to 120 sec

REGULATION CHARACTERISTIC — FIGURE 1

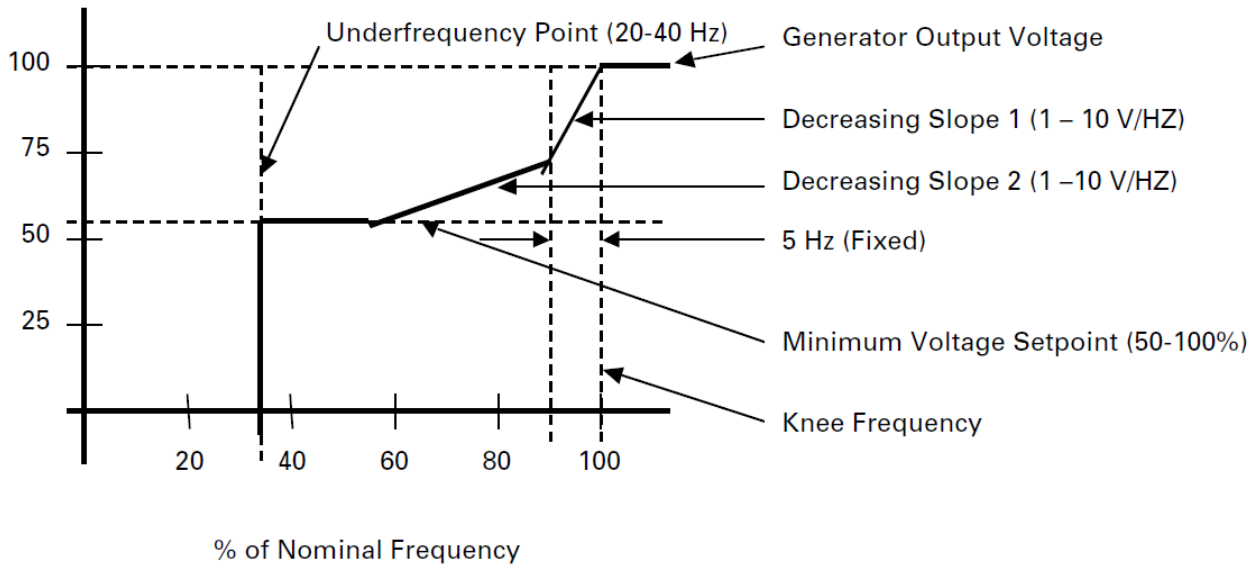

OUTLINE DRAWING — FIGURE 2

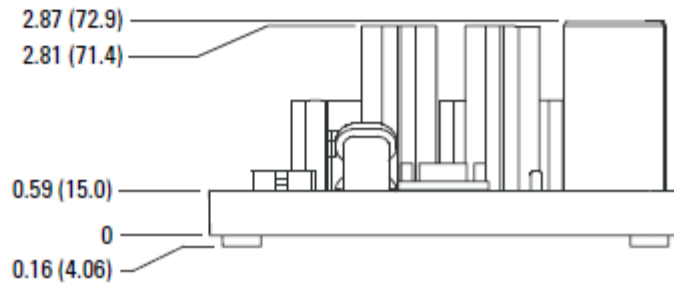
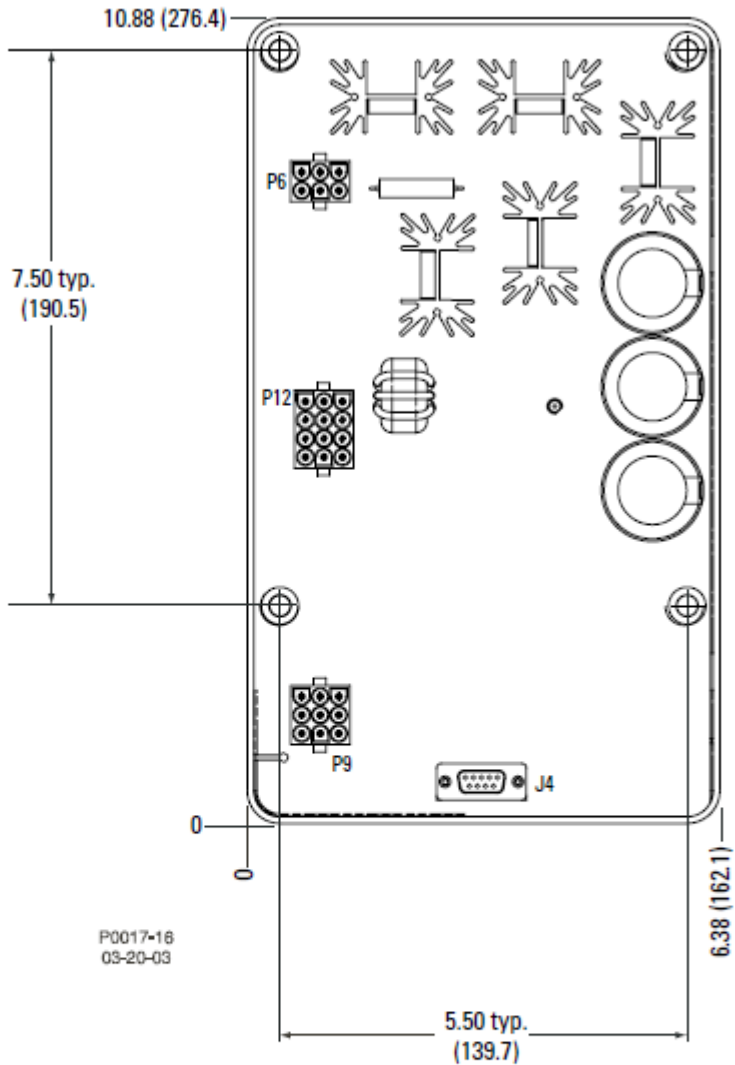

EXAMPLE CONNECTION DIAGRAM — FIGURE 3

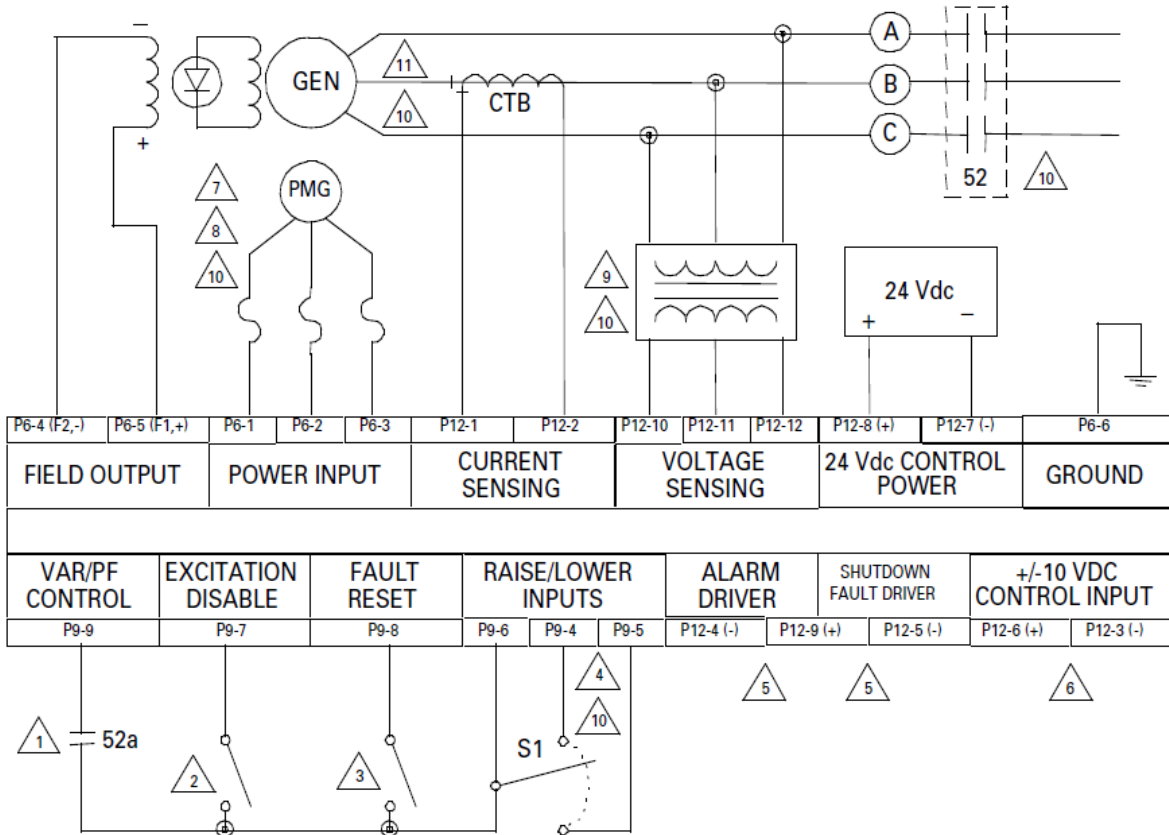

- Required only for Var/PF control. Var/PF is active with 52a closed, inactive with 52a open.
- Excitation is disabled when closed, enabled when open.
- Momentary closure resets any shutdown fault.
- S1 (SPDT, spring -return to center-off position) adjusts regulator setpoint.
- Normally-off, turns on for user alarm or trip.
- Analog input voltage between -10 and +10 Vdc provides adjustment of operating setpoint.
- External fuses should be sized to match the PMG and protect the field. Maximum fuse size should be limited to Bussmann type KTK-12 or equivalent.
- Three-phase PMG is shown. For single-phase PMG, omit P6-3 connection.
- Sensing potential transformer is required if line voltage exceeds 660 Vac.
- Item not supplied by Caterpillar.
- When generator rotation is ACB, the connections shown for CTB should be reversed.

www.cat.com/electricpower

©2020 Caterpillar

All rights reserved.

Materials and specifications are subject to change without notice.

The International System of Units (SI) is used in this publication.

CAT, CATERPILLAR, LET'S DO THE WORK, their respective logos, "Caterpillar Corporate Yellow", the "Power Edge" and Cat "Modern Hex" trade dress as well as corporate and product identity used herein, are trademarks of Caterpillar and may not be used without permission.

Performance Number: EM6671

Change Level: 01

SALES MODEL:	3516C	COMBUSTION:	DIRECT INJECTION
BRAND:	CAT	ENGINE SPEED (RPM):	1,800
MACHINE SALES MODEL:		HERTZ:	60
ENGINE POWER (BHP):	3,634	FAN POWER (HP):	130.1
GEN POWER WITH FAN (EKW):	2,500.0	ASPIRATION:	TA
COMPRESSION RATIO:	14.7	AFTERCOOLER TYPE:	ATAAC
RATING LEVEL:	MISSION CRITICAL STANDBY	AFTERCOOLER CIRCUIT TYPE:	JW+OC, ATAAC
PUMP QUANTITY:	1	INLET MANIFOLD AIR TEMP (F):	122
FUEL TYPE:	DIESEL	JACKET WATER TEMP (F):	219.2
MANIFOLD TYPE:	DRY	TURBO CONFIGURATION:	PARALLEL
GOVERNOR TYPE:	ADEM6	TURBO QUANTITY:	4
ELECTRONICS TYPE:	ADEM6	TURBOCHARGER MODEL:	GT6041BN-48T-1.10
CAMSHAFT TYPE:	STANDARD	CERTIFICATION YEAR:	2025
IGNITION TYPE:	CI	CRANKCASE BLOWBY RATE (FT3/HR):	3,619.4
INJECTOR TYPE:	EUI	FUEL RATE (RATED RPM) NO LOAD (GAL/HR):	16.0
FUEL INJECTOR:	3920221	PISTON SPD @ RATED ENG SPD (FT/MIN):	2,539.4
UNIT INJECTOR TIMING (IN):	64.34		
REF EXH STACK DIAMETER (IN):	12		
MAX OPERATING ALTITUDE (FT):	2,953		

INDUSTRY	SubIndustry	APPLICATION
OIL AND GAS	LAND PRODUCTION	PACKAGED GENSET
ELECTRIC POWER	STANDARD	PACKAGED GENSET

General Performance Data

Note(s)
THIS STANDBY RATING IS FOR A STANDBY ONLY ENGINE ARRANGEMENT. RERATING THE ENGINE TO A PRIME OR CONTINUOUS RATING IS NOT PERMITTED.
THE INLET MANIFOLD AIR TEMP LISTED IN THE HEADER, AND IN THE GENERAL PERFORMANCE DATA, IS THE AVERAGE INLET MANIFOLD TEMP FRONT TO REAR ON THE ENGINE.

GENSET POWER WITH FAN	PERCENT LOAD	ENGINE POWER	BRAKE MEAN EFF PRES (BMEP)	BRAKE SPEC FUEL CONSUMPTN (BSFC)	ISO BRAKE SPEC FUEL CONSUMPTN (BSFC)	VOL FUEL CONSUMPTN (VFC)	ISO VOL FUEL CONSUMPTN (VFC)	ELEC SPEC FUEL CONSUMPTN (ESFC)	ISO ELEC SPEC FUEL CONSUMPTN (ESFC)
EKW	%	BHP	PSI	LB/BHP-HR	LB/BHP-HR	GAL/HR	GAL/HR	LB/EKW-HR	LB/EKW-HR
2,500.0	100	3,633	336	0.334	0.328	171.3	168.0	0.486	0.477
2,250.0	90	3,283	303	0.335	0.329	155.1	152.1	0.489	0.480
2,000.0	80	2,935	271	0.339	0.333	140.4	137.7	0.498	0.489
1,875.0	75	2,760	255	0.342	0.336	133.2	130.7	0.504	0.494
1,750.0	70	2,586	239	0.346	0.339	126.0	123.6	0.511	0.501
1,500.0	60	2,237	207	0.354	0.347	111.5	109.4	0.527	0.517
1,250.0	50	1,889	174	0.365	0.358	97.1	95.2	0.551	0.540
1,000.0	40	1,547	143	0.373	0.366	81.4	79.8	0.577	0.566
750.0	30	1,203	111	0.385	0.378	65.3	64.1	0.618	0.606
625.0	25	1,029	95	0.394	0.386	57.2	56.1	0.649	0.637
500.0	20	854	79	0.403	0.396	48.6	47.6	0.689	0.676
250.0	10	497	46	0.441	0.433	30.9	30.3	0.877	0.860

GENSET POWER WITH FAN	PERCENT LOAD	ENGINE POWER	INLET MFLD PRES	INLET MFLD TEMP	EXH MFLD TEMP	EXH MFLD PRES	ENGINE OUTLET TEMP	COMPRESSOR OUTLET PRES	COMPRESSOR OUTLET TEMP
EKW	%	BHP	IN-HG	DEG F	DEG F	IN-HG	DEG F	IN-HG	DEG F
2,500.0	100	3,633	78.1	121.9	1,235.7	67.6	853.1	85	466.7
2,250.0	90	3,283	71.3	119.4	1,190.0	61.3	824.5	78	443.1
2,000.0	80	2,935	64.3	116.9	1,158.9	55.3	810.7	70	417.8
1,875.0	75	2,760	60.7	115.8	1,145.6	52.3	804.8	66	404.7
1,750.0	70	2,586	57.1	114.7	1,133.3	49.3	798.9	63	391.3
1,500.0	60	2,237	49.5	112.7	1,112.4	43.2	787.1	55	363.6
1,250.0	50	1,889	41.3	111.0	1,091.8	36.8	775.1	46	334.7
1,000.0	40	1,547	31.4	109.4	1,061.5	29.3	770.6	36	297.5
750.0	30	1,203	21.7	107.9	1,010.3	22.1	752.8	25	249.8
625.0	25	1,029	17.2	107.2	968.3	18.7	731.8	21	223.4
500.0	20	854	12.7	106.4	902.0	15.5	695.6	16	197.2
250.0	10	497	4.8	104.1	700.7	9.8	562.6	7	152.3

GENSET POWER WITH FAN	PERCENT LOAD	ENGINE POWER	WET INLET AIR VOL FLOW RATE	ENGINE OUTLET WET EXH GAS VOL FLOW RATE	WET INLET AIR MASS FLOW RATE	WET EXH GAS MASS FLOW RATE	WET EXH VOL FLOW RATE (32 DEG F AND 29.98 IN HG)	DRY EXH VOL FLOW RATE (32 DEG F AND 29.98 IN HG)
EKW	%	BHP	CFM	CFM	LB/HR	LB/HR	FT3/MIN	FT3/MIN
2,500.0	100	3,633	7,133.1	18,497.4	31,696.1	32,910.2	6,927.7	6,289.9

2,250.0	90	3,283	6,756.8	17,036.6	29,886.4	30,985.9	6,522.8	5,944.9
2,000.0	80	2,935	6,350.9	15,740.8	28,028.8	29,019.5	6,092.1	5,568.4
1,875.0	75	2,760	6,132.5	15,125.9	27,059.2	27,998.2	5,881.4	5,382.5
1,750.0	70	2,586	5,902.5	14,507.6	26,056.9	26,945.9	5,667.5	5,192.6
1,500.0	60	2,237	5,408.9	13,196.0	23,934.4	24,726.5	5,204.1	4,777.6
1,250.0	50	1,889	4,844.0	11,701.1	21,447.3	22,136.3	4,659.1	4,284.7
1,000.0	40	1,547	4,122.0	9,918.3	18,264.4	18,842.5	3,963.7	3,647.8
750.0	30	1,203	3,423.6	8,121.4	15,177.8	15,642.9	3,293.2	3,036.5
625.0	25	1,029	3,105.0	7,237.8	13,766.9	14,173.7	2,986.8	2,759.5
500.0	20	854	2,791.1	6,276.7	12,375.6	12,721.7	2,671.3	2,475.8
250.0	10	497	2,236.2	4,428.4	9,910.4	10,129.4	2,129.9	1,997.8

Heat Rejection Data

GENSET POWER WITH FAN	PERCENT LOAD	ENGINE POWER	REJECTION TO JACKET WATER	REJECTION TO ATMOSPHERE	REJECTION TO EXH	EXHAUST RECOVERY TO 350F	FROM OIL COOLER	FROM AFTERCOOLER	WORK ENERGY	LOW HEAT VALUE ENERGY	HIGH HEAT VALUE ENERGY
EKW	%	BHP	BTU/MIN	BTU/MIN	BTU/MIN	BTU/MIN	BTU/MIN	BTU/MIN	BTU/MIN	BTU/MIN	BTU/MIN
2,500.0	100	3,633	46,992	9,146	142,265	70,115	19,835	44,723	154,077	372,403	396,702
2,250.0	90	3,283	44,242	8,557	127,929	62,041	17,960	39,380	139,243	337,204	359,207
2,000.0	80	2,935	41,477	8,162	116,879	56,282	16,262	34,167	124,444	305,311	325,233
1,875.0	75	2,760	40,076	8,007	111,588	53,551	15,425	31,612	117,053	289,608	308,505
1,750.0	70	2,586	38,657	7,874	106,293	50,817	14,588	29,085	109,651	273,881	291,752
1,500.0	60	2,237	35,755	7,684	95,729	45,311	12,915	24,201	94,874	242,485	258,307
1,250.0	50	1,889	32,626	7,527	85,184	39,388	11,245	19,401	80,109	211,118	224,893
1,000.0	40	1,547	29,235	7,262	72,693	33,148	9,427	13,873	65,583	176,995	188,544
750.0	30	1,203	25,476	6,784	59,425	26,293	7,565	8,706	51,005	142,037	151,305
625.0	25	1,029	23,394	6,435	52,542	22,520	6,621	6,496	43,653	124,317	132,429
500.0	20	854	21,006	5,995	44,739	18,221	5,624	4,534	36,223	105,594	112,484
250.0	10	497	15,737	5,026	27,795	8,787	3,578	1,916	21,071	67,181	71,564

Sound Data

EXHAUST:SOUND PRESSURE(OBCF) DISTANCE:1.5 METER

GENSET POWER WITH FAN	PERCENT LOAD	ENGINE POWER	OVERALL SOUND	63 HZ	125 HZ	250 HZ	500 HZ
EKW	%	BHP	dB(A)	dB(A)	dB(A)	dB(A)	dB(A)
2,500.0	100	3,633	119.0	109.0	124.0	120.0	112.0
2,250.0	90	3,283	118.0	108.0	123.0	119.0	111.0
2,000.0	80	2,935	117.0	107.0	122.0	118.0	110.0
1,875.0	75	2,760	116.0	106.0	121.0	117.0	109.0
1,750.0	70	2,586	115.0	106.0	120.0	116.0	108.0

1,500.0	60	2,237	114.0	104.0	119.0	115.0	107.0
1,250.0	50	1,889	113.0	103.0	118.0	114.0	106.0
1,000.0	40	1,547	111.0	102.0	116.0	112.0	104.0
750.0	30	1,203	110.0	100.0	115.0	111.0	103.0
625.0	25	1,029	109.0	99.0	114.0	110.0	102.0
500.0	20	854	108.0	98.0	113.0	109.0	101.0
250.0	10	497	105.0	95.0	110.0	106.0	98.0

EXHAUST:SOUND PRESSURE(OBCF) DISTANCE:1.5 METER

GENSET POWER WITH FAN	PERCENT LOAD	ENGINE POWER	1000 HZ	2000 HZ	4000 HZ	8000 HZ
EKW	%	BHP	dB(A)	dB(A)	dB(A)	dB(A)
2,500.0	100	3,633	110.0	112.0	111.0	110.0
2,250.0	90	3,283	109.0	111.0	110.0	108.0
2,000.0	80	2,935	108.0	109.0	109.0	107.0
1,875.0	75	2,760	108.0	109.0	109.0	107.0
1,750.0	70	2,586	107.0	108.0	108.0	106.0
1,500.0	60	2,237	106.0	107.0	107.0	105.0
1,250.0	50	1,889	104.0	106.0	105.0	103.0
1,000.0	40	1,547	103.0	104.0	104.0	102.0
750.0	30	1,203	101.0	102.0	102.0	100.0
625.0	25	1,029	100.0	101.0	101.0	99.0
500.0	20	854	99.0	100.0	100.0	98.0
250.0	10	497	97.0	98.0	98.0	96.0

EXHAUST:SOUND PRESSURE(OBCF) DISTANCE:7 METER

GENSET POWER WITH FAN	PERCENT LOAD	ENGINE POWER	OVERALL SOUND	63 HZ	125 HZ	250 HZ	500 HZ
EKW	%	BHP	dB(A)	dB(A)	dB(A)	dB(A)	dB(A)
2,500.0	100	3,633	105.0	97.0	113.0	108.0	99.0
2,250.0	90	3,283	104.0	96.0	112.0	107.0	98.0
2,000.0	80	2,935	103.0	95.0	111.0	105.0	97.0
1,875.0	75	2,760	103.0	94.0	111.0	105.0	96.0
1,750.0	70	2,586	102.0	93.0	110.0	104.0	96.0
1,500.0	60	2,237	101.0	92.0	109.0	103.0	94.0
1,250.0	50	1,889	99.0	91.0	107.0	102.0	93.0
1,000.0	40	1,547	98.0	89.0	106.0	100.0	92.0
750.0	30	1,203	96.0	88.0	104.0	98.0	90.0
625.0	25	1,029	95.0	87.0	103.0	97.0	89.0

500.0	20	854	94.0	86.0	102.0	96.0	88.0
250.0	10	497	92.0	83.0	100.0	94.0	85.0

EXHAUST:SOUND PRESSURE(OBCF) DISTANCE:7 METER

GENSET POWER WITH FAN	PERCENT LOAD	ENGINE POWER	1000 HZ	2000 HZ	4000 HZ	8000 HZ
EKW	%	BHP	dB(A)	dB(A)	dB(A)	dB(A)
2,500.0	100	3,633	97.0	98.0	98.0	95.0
2,250.0	90	3,283	96.0	97.0	97.0	94.0
2,000.0	80	2,935	95.0	96.0	96.0	93.0
1,875.0	75	2,760	95.0	95.0	95.0	92.0
1,750.0	70	2,586	94.0	95.0	95.0	92.0
1,500.0	60	2,237	93.0	93.0	93.0	91.0
1,250.0	50	1,889	91.0	92.0	92.0	89.0
1,000.0	40	1,547	90.0	91.0	90.0	88.0
750.0	30	1,203	88.0	89.0	89.0	86.0
625.0	25	1,029	87.0	88.0	88.0	85.0
500.0	20	854	86.0	87.0	87.0	84.0
250.0	10	497	84.0	85.0	84.0	82.0

EXHAUST:SOUND PRESSURE(OBCF) DISTANCE:15 METER

GENSET POWER WITH FAN	PERCENT LOAD	ENGINE POWER	OVERALL SOUND	63 HZ	125 HZ	250 HZ	500 HZ
EKW	%	BHP	dB(A)	dB(A)	dB(A)	dB(A)	dB(A)
2,500.0	100	3,633	99.0	90.0	107.0	101.0	92.0
2,250.0	90	3,283	98.0	89.0	106.0	100.0	91.0
2,000.0	80	2,935	97.0	88.0	105.0	99.0	90.0
1,875.0	75	2,760	96.0	87.0	104.0	98.0	90.0
1,750.0	70	2,586	95.0	87.0	103.0	98.0	89.0
1,500.0	60	2,237	94.0	86.0	102.0	96.0	88.0
1,250.0	50	1,889	93.0	84.0	101.0	95.0	86.0
1,000.0	40	1,547	91.0	83.0	99.0	93.0	85.0
750.0	30	1,203	90.0	81.0	98.0	92.0	83.0
625.0	25	1,029	89.0	80.0	97.0	91.0	82.0
500.0	20	854	88.0	79.0	96.0	90.0	81.0
250.0	10	497	85.0	77.0	93.0	87.0	79.0

EXHAUST:SOUND PRESSURE(OBCF) DISTANCE:15 METER

GENSET POWER WITH FAN	PERCENT LOAD	ENGINE POWER	1000 HZ	2000 HZ	4000 HZ	8000 HZ
EKW	%	BHP	dB(A)	dB(A)	dB(A)	dB(A)
2,500.0	100	3,633	91.0	92.0	91.0	89.0
2,250.0	90	3,283	90.0	90.0	90.0	88.0
2,000.0	80	2,935	89.0	89.0	89.0	86.0
1,875.0	75	2,760	88.0	89.0	89.0	86.0
1,750.0	70	2,586	87.0	88.0	88.0	85.0
1,500.0	60	2,237	86.0	87.0	87.0	84.0
1,250.0	50	1,889	85.0	85.0	85.0	83.0
1,000.0	40	1,547	83.0	84.0	84.0	81.0
750.0	30	1,203	82.0	82.0	82.0	79.0
625.0	25	1,029	81.0	81.0	81.0	78.0
500.0	20	854	80.0	80.0	80.0	77.0
250.0	10	497	77.0	78.0	78.0	75.0

MECHANICAL:SOUND PRESSURE(OBCF) DISTANCE:1 METER

GENSET POWER WITH FAN	PERCENT LOAD	ENGINE POWER	OVERALL SOUND	63 HZ	125 HZ	250 HZ	500 HZ
EKW	%	BHP	dB(A)	dB(A)	dB(A)	dB(A)	dB(A)
2,500.0	100	3,633	105.0	92.0	100.0	101.0	99.0
2,250.0	90	3,283	105.0	92.0	100.0	101.0	99.0
2,000.0	80	2,935	105.0	92.0	100.0	101.0	99.0
1,875.0	75	2,760	105.0	92.0	100.0	101.0	99.0
1,750.0	70	2,586	105.0	92.0	100.0	101.0	99.0
1,500.0	60	2,237	105.0	92.0	100.0	101.0	99.0
1,250.0	50	1,889	105.0	92.0	100.0	101.0	99.0
1,000.0	40	1,547	105.0	92.0	100.0	101.0	99.0
750.0	30	1,203	105.0	92.0	100.0	101.0	99.0
625.0	25	1,029	105.0	92.0	100.0	101.0	99.0
500.0	20	854	105.0	92.0	100.0	101.0	99.0
250.0	10	497	105.0	92.0	100.0	101.0	99.0

MECHANICAL:SOUND PRESSURE(OBCF) DISTANCE:1 METER

GENSET POWER WITH FAN	PERCENT LOAD	ENGINE POWER	1000 HZ	2000 HZ	4000 HZ	8000 HZ
EKW	%	BHP	dB(A)	dB(A)	dB(A)	dB(A)
2,500.0	100	3,633	100.0	101.0	99.0	103.0
2,250.0	90	3,283	100.0	101.0	99.0	103.0
2,000.0	80	2,935	100.0	101.0	99.0	103.0

1,875.0	75	2,760	100.0	101.0	99.0	103.0
1,750.0	70	2,586	100.0	101.0	99.0	103.0
1,500.0	60	2,237	100.0	101.0	99.0	103.0
1,250.0	50	1,889	100.0	101.0	99.0	103.0
1,000.0	40	1,547	100.0	101.0	99.0	103.0
750.0	30	1,203	100.0	101.0	99.0	103.0
625.0	25	1,029	100.0	101.0	99.0	103.0
500.0	20	854	100.0	101.0	99.0	103.0
250.0	10	497	100.0	101.0	99.0	103.0

MECHANICAL:SOUND PRESSURE(OBCF) DISTANCE:7 METER

GENSET POWER WITH FAN	PERCENT LOAD	ENGINE POWER	OVERALL SOUND	63 HZ	125 HZ	250 HZ	500 HZ
EKW	%	BHP	dB(A)	dB(A)	dB(A)	dB(A)	dB(A)
2,500.0	100	3,633	94.0	81.0	88.0	89.0	87.0
2,250.0	90	3,283	94.0	81.0	88.0	89.0	87.0
2,000.0	80	2,935	94.0	81.0	88.0	89.0	87.0
1,875.0	75	2,760	94.0	81.0	88.0	89.0	87.0
1,750.0	70	2,586	94.0	81.0	88.0	89.0	87.0
1,500.0	60	2,237	94.0	81.0	88.0	89.0	87.0
1,250.0	50	1,889	94.0	81.0	88.0	89.0	87.0
1,000.0	40	1,547	94.0	81.0	88.0	89.0	87.0
750.0	30	1,203	94.0	81.0	88.0	89.0	87.0
625.0	25	1,029	94.0	81.0	88.0	89.0	87.0
500.0	20	854	94.0	81.0	88.0	89.0	87.0
250.0	10	497	94.0	81.0	88.0	89.0	87.0

MECHANICAL:SOUND PRESSURE(OBCF) DISTANCE:7 METER

GENSET POWER WITH FAN	PERCENT LOAD	ENGINE POWER	1000 HZ	2000 HZ	4000 HZ	8000 HZ
EKW	%	BHP	dB(A)	dB(A)	dB(A)	dB(A)
2,500.0	100	3,633	89.0	90.0	87.0	91.0
2,250.0	90	3,283	89.0	90.0	87.0	91.0
2,000.0	80	2,935	89.0	90.0	87.0	91.0
1,875.0	75	2,760	89.0	90.0	87.0	91.0
1,750.0	70	2,586	89.0	90.0	87.0	91.0
1,500.0	60	2,237	89.0	90.0	87.0	91.0
1,250.0	50	1,889	89.0	90.0	87.0	91.0
1,000.0	40	1,547	89.0	90.0	87.0	91.0

750.0	30	1,203	89.0	90.0	87.0	91.0
625.0	25	1,029	89.0	90.0	87.0	91.0
500.0	20	854	89.0	90.0	87.0	91.0
250.0	10	497	89.0	90.0	87.0	91.0

MECHANICAL:SOUND PRESSURE(OBCF) DISTANCE:15 METER

GENSET POWER WITH FAN	PERCENT LOAD	ENGINE POWER	OVERALL SOUND	63 HZ	125 HZ	250 HZ	500 HZ
EKW	%	BHP	dB(A)	dB(A)	dB(A)	dB(A)	dB(A)
2,500.0	100	3,633	88.0	76.0	83.0	84.0	82.0
2,250.0	90	3,283	88.0	76.0	83.0	84.0	82.0
2,000.0	80	2,935	88.0	76.0	83.0	84.0	82.0
1,875.0	75	2,760	88.0	76.0	83.0	84.0	82.0
1,750.0	70	2,586	88.0	76.0	83.0	84.0	82.0
1,500.0	60	2,237	88.0	76.0	83.0	84.0	82.0
1,250.0	50	1,889	88.0	76.0	83.0	84.0	82.0
1,000.0	40	1,547	88.0	76.0	83.0	84.0	82.0
750.0	30	1,203	88.0	76.0	83.0	84.0	82.0
625.0	25	1,029	88.0	76.0	83.0	84.0	82.0
500.0	20	854	88.0	76.0	83.0	84.0	82.0
250.0	10	497	88.0	76.0	83.0	84.0	82.0

MECHANICAL:SOUND PRESSURE(OBCF) DISTANCE:15 METER

GENSET POWER WITH FAN	PERCENT LOAD	ENGINE POWER	1000 HZ	2000 HZ	4000 HZ	8000 HZ
EKW	%	BHP	dB(A)	dB(A)	dB(A)	dB(A)
2,500.0	100	3,633	83.0	84.0	82.0	86.0
2,250.0	90	3,283	83.0	84.0	82.0	86.0
2,000.0	80	2,935	83.0	84.0	82.0	86.0
1,875.0	75	2,760	83.0	84.0	82.0	86.0
1,750.0	70	2,586	83.0	84.0	82.0	86.0
1,500.0	60	2,237	83.0	84.0	82.0	86.0
1,250.0	50	1,889	83.0	84.0	82.0	86.0
1,000.0	40	1,547	83.0	84.0	82.0	86.0
750.0	30	1,203	83.0	84.0	82.0	86.0
625.0	25	1,029	83.0	84.0	82.0	86.0
500.0	20	854	83.0	84.0	82.0	86.0
250.0	10	497	83.0	84.0	82.0	86.0

Emissions Data

DIESEL

GENSET POWER WITH FAN		EKW	2,500.0	1,875.0	1,250.0	625.0	250.0
ENGINE POWER		BHP	3,633	2,760	1,889	1,029	497
PERCENT LOAD		%	100	75	50	25	10
TOTAL NOX (AS NO2)		G/HR	19,123	11,751	5,837	2,974	2,654
TOTAL CO		G/HR	1,515	725	607	831	1,165
TOTAL HC		G/HR	376	375	408	307	329
TOTAL CO2		KG/HR	1,740	1,340	966	559	296
PART MATTER		G/HR	132.5	88.4	94.3	99.6	100.7
TOTAL NOX (AS NO2)	(CORR 5% O2)	MG/NM3	2,349.1	1,857.9	1,286.9	1,127.3	1,858.5
TOTAL CO	(CORR 5% O2)	MG/NM3	195.4	118.8	140.1	330.3	862.6
TOTAL HC	(CORR 5% O2)	MG/NM3	42.1	54.8	81.8	105.8	212.3
PART MATTER	(CORR 5% O2)	MG/NM3	14.1	11.8	18.4	34.7	63.0
TOTAL NOX (AS NO2)	(CORR 15% O2)	MG/NM3	871.7	689.4	477.5	418.3	689.6
TOTAL CO	(CORR 15% O2)	MG/NM3	72.5	44.1	52.0	122.6	320.1
TOTAL HC	(CORR 15% O2)	MG/NM3	15.6	20.3	30.4	39.3	78.8
PART MATTER	(CORR 15% O2)	MG/NM3	5.2	4.4	6.8	12.9	23.4
TOTAL NOX (AS NO2)	(CORR 5% O2)	PPM	1,144	905	627	549	905
TOTAL CO	(CORR 5% O2)	PPM	156	95	112	264	690
TOTAL HC	(CORR 5% O2)	PPM	79	102	153	197	396
TOTAL NOX (AS NO2)	(CORR 15% O2)	PPM	425	336	233	204	336
TOTAL CO	(CORR 15% O2)	PPM	58	35	42	98	256
TOTAL HC	(CORR 15% O2)	PPM	29	38	57	73	147
TOTAL NOX (AS NO2)		G/HP-HR	5.32	4.30	3.12	2.92	5.39
TOTAL CO		G/HP-HR	0.42	0.26	0.32	0.82	2.37
TOTAL HC		G/HP-HR	0.10	0.14	0.22	0.30	0.67
PART MATTER		G/HP-HR	0.04	0.03	0.05	0.10	0.20
TOTAL NOX (AS NO2)		G/KW-HR	7.13	5.76	4.18	3.91	7.23
TOTAL CO		G/KW-HR	0.56	0.36	0.43	1.09	3.17
TOTAL HC		G/KW-HR	0.14	0.18	0.29	0.40	0.89
PART MATTER		G/KW-HR	0.05	0.04	0.07	0.13	0.27
TOTAL NOX (AS NO2)		LB/HR	42.16	25.91	12.87	6.56	5.85
TOTAL CO		LB/HR	3.34	1.60	1.34	1.83	2.57
TOTAL HC		LB/HR	0.83	0.83	0.90	0.68	0.72
TOTAL CO2		LB/HR	3,836	2,955	2,130	1,233	654
PART MATTER		LB/HR	0.29	0.19	0.21	0.22	0.22
OXYGEN IN EXH		%	9.4	10.4	11.3	12.2	14.4
DRY SMOKE OPACITY		%	1.7	1.4	1.9	2.6	4.0
BOSCH SMOKE NUMBER			0.83	0.80	0.85	0.97	1.13

RATED SPEED POTENTIAL SITE VARIATION: 1800 RPM

GENSET POWER WITH FAN		EKW	2,500.0	1,875.0	1,250.0	625.0	250.0
ENGINE POWER		BHP	3,633	2,760	1,889	1,029	497
PERCENT LOAD		%	100	75	50	25	10
TOTAL NOX (AS NO2)		G/HR	22,948	14,101	7,004	3,568	3,185
TOTAL CO		G/HR	2,726	1,304	1,092	1,496	2,098
TOTAL HC		G/HR	500	499	543	408	437
PART MATTER		G/HR	185.5	123.7	132.1	139.5	141.0
TOTAL NOX (AS NO2)	(CORR 5% O2)	MG/NM3	2,818.9	2,229.5	1,544.3	1,352.7	2,230.2
TOTAL CO	(CORR 5% O2)	MG/NM3	351.8	213.9	252.3	594.6	1,552.7
TOTAL HC	(CORR 5% O2)	MG/NM3	55.9	72.8	108.8	140.7	282.4
PART MATTER	(CORR 5% O2)	MG/NM3	19.7	16.5	25.8	48.5	88.2
TOTAL NOX (AS NO2)	(CORR 15% O2)	MG/NM3	1,046.0	827.3	573.0	502.0	827.6
TOTAL CO	(CORR 15% O2)	MG/NM3	130.5	79.4	93.6	220.6	576.2
TOTAL HC	(CORR 15% O2)	MG/NM3	20.8	27.0	40.4	52.2	104.8
PART MATTER	(CORR 15% O2)	MG/NM3	7.3	6.1	9.6	18.0	32.7
TOTAL NOX (AS NO2)	(CORR 5% O2)	PPM	1,373	1,086	752	659	1,086
TOTAL CO	(CORR 5% O2)	PPM	281	171	202	476	1,242
TOTAL HC	(CORR 5% O2)	PPM	104	136	203	263	527
TOTAL NOX (AS NO2)	(CORR 15% O2)	PPM	510	403	279	244	403
TOTAL CO	(CORR 15% O2)	PPM	104	63	75	177	461
TOTAL HC	(CORR 15% O2)	PPM	39	50	75	97	196
TOTAL NOX (AS NO2)		G/HP-HR	6.38	5.15	3.74	3.50	6.47
TOTAL CO		G/HP-HR	0.76	0.48	0.58	1.47	4.26
TOTAL HC		G/HP-HR	0.14	0.18	0.29	0.40	0.89
PART MATTER		G/HP-HR	0.05	0.05	0.07	0.14	0.29
TOTAL NOX (AS NO2)		G/KW-HR	8.55	6.91	5.02	4.69	8.67
TOTAL CO		G/KW-HR	1.02	0.64	0.78	1.97	5.71
TOTAL HC		G/KW-HR	0.19	0.24	0.39	0.54	1.19
PART MATTER		G/KW-HR	0.07	0.06	0.09	0.18	0.38
TOTAL NOX (AS NO2)		LB/HR	50.59	31.09	15.44	7.87	7.02
TOTAL CO		LB/HR	6.01	2.88	2.41	3.30	4.62
TOTAL HC		LB/HR	1.10	1.10	1.20	0.90	0.96
PART MATTER		LB/HR	0.41	0.27	0.29	0.31	0.31

Regulatory Information

EPA EMERGENCY STATIONARY	2011 - ----	CYCLE : D2
<p>GASEOUS EMISSIONS DATA MEASUREMENTS PROVIDED TO THE EPA ARE CONSISTENT WITH THOSE DESCRIBED IN EPA 40 CFR PART 60 SUBPART IIII AND ISO 8178 FOR MEASURING HC, CO, PM, AND NOX. THE "MAX LIMITS" SHOWN BELOW ARE WEIGHTED CYCLE AVERAGES AND ARE IN COMPLIANCE WITH THE EMERGENCY STATIONARY REGULATIONS.</p>		

Locality	Agency	Regulation	Tier/Stage	Max Limits - G/BKW - HR
U.S. (INCL CALIF)	EPA	STATIONARY	EMERGENCY STATIONARY	CO: 3.5 NOx + HC: 6.4 PM: 0.20

Altitude Derate Data

STANDARD

ALTITUDE CORRECTED POWER CAPABILITY (BHP)

AMBIENT OPERATING TEMP (F)	30	40	50	60	70	80	90	100	110	120	NORMAL
ALTITUDE (FT)											
0	3,634	3,634	3,634	3,634	3,634	3,634	3,634	3,634	3,634	3,634	3,634
1,000	3,634	3,634	3,634	3,634	3,634	3,634	3,634	3,634	3,634	3,561	3,634
2,000	3,634	3,634	3,634	3,634	3,634	3,634	3,634	3,604	3,541	3,480	3,634
3,000	3,628	3,628	3,628	3,628	3,628	3,603	3,537	3,474	3,413	3,354	3,628
4,000	3,504	3,504	3,504	3,504	3,504	3,471	3,408	3,347	3,289	3,232	3,504
5,000	3,384	3,384	3,384	3,384	3,384	3,344	3,283	3,225	3,168	3,113	3,384
6,000	3,269	3,269	3,269	3,269	3,269	3,221	3,162	3,105	3,051	2,998	3,269
7,000	3,159	3,159	3,159	3,159	3,159	3,101	3,044	2,990	2,937	2,887	3,159
8,000	3,052	3,052	3,052	3,052	3,041	2,985	2,930	2,878	2,827	2,779	3,052
9,000	2,950	2,950	2,950	2,950	2,926	2,872	2,820	2,769	2,721	2,674	2,950
10,000	2,851	2,851	2,851	2,851	2,815	2,763	2,713	2,664	2,617	2,544	2,851

Cross Reference

Test Spec	Setting	Engine Arrangement	Engineering Model	Engineering Model Version	Start Effective Serial Number	End Effective Serial Number
5978216	LL3414	6444179	PG608	-	EZG00001	
6666111	GG1627	6631037	PG656	XJ	KZG00001	

Performance Parameter Reference

<p>Parameters Reference: DM9600 - 15</p> <p>PERFORMANCE DEFINITIONS</p> <p>PERFORMANCE DEFINITIONS DM9600</p> <p>APPLICATION: Engine performance tolerance values below are representative of a typical production engine tested in a calibrated dynamometer test cell at SAE J1995 standard reference conditions. Caterpillar maintains ISO9001:2000 certified quality management systems for engine test Facilities to assure accurate calibration of test equipment. Engine test data is corrected in accordance with SAE J1995. Additional reference material SAE J1228, J1349, ISO 8665, 3046-1:2002E, 3046-3:1989, 1585, 2534, 2288, and 9249 may apply in part or are similar to SAE J1995. Special engine rating request (SERR) test data shall be noted.</p> <p>PERFORMANCE PARAMETER TOLERANCE FACTORS: Power +/- 3% Torque +/- 3% Exhaust stack temperature +/- 8% Inlet airflow +/- 5% Intake manifold pressure-gage +/- 10% Exhaust flow +/- 6% Specific fuel consumption +/- 3% Specific fuel consumption (C7-C18) +/- 4% Fuel rate +/- 5% Specific DEF consumption +/- 3% DEF rate +/- 5% Heat rejection +/- 5% Heat rejection exhaust only +/- 10% Heat rejection CEM only +/- 10%</p>

Heat Rejection values based on using treated water.

Torque is included for truck and industrial applications, do not use for Gen Set or steady state applications.

On C7 - C18 engines, at speeds of 1100 RPM and under these values are provided for reference only, and may not meet the tolerance listed.

On 3500 and C175 engines, at speeds below Peak Torque these values are provided for reference only, and may not meet the tolerance listed.

These values do not apply to C280/3600. For these models, see the tolerances listed below.

C280/3600 HEAT REJECTION TOLERANCE FACTORS: Heat rejection +/- 10% Heat rejection to Atmosphere +/- 50% Heat rejection to Lube Oil +/- 20% Heat rejection to Aftercooler +/- 5%

TEST CELL TRANSDUCER TOLERANCE FACTORS: Torque +/- 0.5% Speed +/- 0.2% Fuel flow +/- 1.0% Temperature +/- 2.0 C degrees Intake manifold pressure +/- 0.1 kPa

OBSERVED ENGINE PERFORMANCE IS CORRECTED TO SAE J1995 REFERENCE AIR AND FUEL CONDITIONS.

REFERENCE ATMOSPHERIC INLET AIR FOR 3500 ENGINES AND SMALLER SAE J1228 AUG2002 for marine engines, and J1995 JAN2014 for other engines, reference atmospheric pressure is 100 KPA (29.61 in hg), and standard temperature is 25deg C (77 deg F) at 30% relative humidity at the stated aftercooler water temp, or inlet manifold temp.

FOR 3600 ENGINES Engine rating obtained and presented in accordance with ISO 3046/1 and SAE J1995 JAN2014 reference atmospheric pressure is 100 KPA (29.61 in hg), and standard temperature is 25deg C (77 deg F) at 30% relative humidity and 150M altitude at the stated aftercooler water temperature.

MEASUREMENT LOCATION FOR INLET AIR TEMPERATURE Location for air temperature measurement air cleaner inlet at stabilized operating conditions.

REFERENCE EXHAUST STACK DIAMETER The Reference Exhaust Stack Diameter published with this dataset is only used for the calculation of Smoke Opacity values displayed in this dataset. This value does not necessarily represent the actual stack diameter of the engine due to the variety of exhaust stack adapter options available. Consult the price list, engine order or general dimension drawings for the actual stack diameter size ordered or options available.

REFERENCE FUEL DIESEL Reference fuel is #2 distillate diesel with a 35API gravity; A lower heating value is 42,780 KJ/KG (18,390 BTU/LB) when used at 15 deg C (59 deg F), where the density is 850 G/Liter (7.0936 Lbs/Gal).

GAS Reference natural gas fuel has a lower heating value of 33.74 KJ/L (905 BTU/CU Ft). Low BTU ratings are based on 18.64 KJ/L (500 BTU/CU FT) lower heating value gas. Propane ratings are based on 87.56 KJ/L (2350 BTU/CU Ft) lower heating value gas.

ENGINE POWER (NET) IS THE CORRECTED FLYWHEEL POWER (GROSS) LESS EXTERNAL AUXILIARY LOAD Engine corrected gross output includes the power required to drive standard equipment; lube oil, scavenge lube oil, fuel transfer, common rail fuel, separate circuit aftercooler and jacket water pumps. Engine net power available for the external (flywheel) load is calculated by subtracting the sum of auxiliary load from the corrected gross flywheel out put power. Typical auxiliary loads are radiator cooling fans, hydraulic pumps, air compressors and battery charging alternators. For Tier 4 ratings additional Parasitic losses would also include Intake, and Exhaust Restrictions.

ALTITUDE CAPABILITY Altitude capability is the maximum altitude above sea level at standard temperature and standard pressure at which the engine could develop full rated output power on the current performance data set.

Standard temperature values versus altitude could be seen on TM2001.

When viewing the altitude capability chart the ambient temperature is the inlet air temp at the compressor inlet.

Engines with ADEM MEUI and HEUI fuel systems operating at conditions above the defined altitude capability derate for atmospheric pressure and temperature conditions outside the values defined, see TM2001.

Mechanical governor controlled unit injector engines require a setting change for operation at conditions above the altitude defined on the engine performance sheet. See your Caterpillar technical representative for non standard ratings.

REGULATIONS AND PRODUCT COMPLIANCE TMI Emissions information is presented at 'nominal' and 'Potential Site Variation' values for standard ratings. No tolerances are applied to the emissions data. These values are subject to change at any time. The controlling federal and local emission requirements need to be verified by your Caterpillar technical representative. Customer's may have special emission site requirements that need to be verified by the Caterpillar Product Group engineer.

EMISSION CYCLE LIMITS: Cycle emissions Max Limits apply to cycle-weighted averages only. Emissions at individual load points may exceed the cycle-weighted limit.

WET & DRY EXHAUST/EMISSIONS DESCRIPTION: Wet - Total exhaust flow or concentration of total exhaust flow Dry - Total exhaust flow minus water vapor or concentration of exhaust flow with water vapor excluded

EMISSIONS DEFINITIONS: Emissions : DM1176

EMISSION CYCLE DEFINITIONS

1. For constant-speed marine engines for ship main propulsion, including,diesel-electric drive, test cycle E2 shall be applied, for controllable-pitch propeller sets test cycle E2 shall be applied.
2. For propeller-law-operated main and propeller-law-operated auxiliary engines the test cycle E3 shall be applied.
3. For constant-speed auxiliary engines test cycle D2 shall be applied.
4. For variable-speed, variable-load auxiliary engines, not included above, test cycle C1 shall be applied.

HEAT REJECTION DEFINITIONS: Diesel Circuit Type and HHV Balance : DM9500

HIGH DISPLACEMENT (HD) DEFINITIONS: 3500: EM1500

RATING DEFINITIONS: Agriculture : TM6008

Fire Pump : TM6009

Generator Set : TM6035

Generator (Gas) : TM6041

Industrial Diesel : TM6010

Industrial (Gas) : TM6040

Irrigation : TM5749

Locomotive : TM6037

Marine Auxiliary : TM6036

Marine Prop (Except 3600) : TM5747

Marine Prop (3600 only) : TM5748

MSHA : TM6042

Oil Field (Petroleum) : TM6011

Off-Highway Truck : TM6039

On-Highway Truck : TM6038

SOUND DEFINITIONS: Sound Power : DM8702

Sound Pressure : TM7080

Date Released : 03/12/24

[Spec Info](#) [Mechanical Data](#) [Cooling Data](#) [Motor Starting Curve](#) [Open Circuit Curve](#)
[Zero Power Factor Curve](#) [Reactive Capability Chart](#) [General Information](#)

Selected Model

Engine: 3516 **Generator Frame:** 1670 **Genset Rating (kW):** 2500.0 **Line Voltage:** 480
Fuel: Diesel **Generator Arrangement:** 5493798 **Genset Rating (kVA):** 3125.0 **Phase Voltage:** 277
Frequency: 60 **Excitation Type:** Permanent Magnet **Pwr. Factor:** 0.8 **Rated Current:** 3758.8
Duty: STANDBY **Connection:** SERIES STAR **Application:** EPG **Status:** Current
Version: 41205 /43061 /43741 /11996

Spec Information

Generator Specification		Generator Efficiency			
Frame: 1670	Type: SR5	No. of Bearings: 2	Per Unit Load	kW	Efficiency %
Winding Type: RANDOM WOUND	Flywheel: 21		0.25	625	93.4
Connection: SERIESSTAR	Housing: 00		0.5	1250	95.8
Phases: 3	No. of Leads: 6		0.75	1875	96.3
Poles: 4	Wires per Lead: 4		1	2500	96.3
Sync Speed: 1800	Generator Pitch: 0.6667				

Reactances	Per Unit	Ohms
SUBTRANSIENT - DIRECT AXIS X''_d	0.1248	0.0092
SUBTRANSIENT - QUADRATURE AXIS X''_q	0.1099	0.0081
TRANSIENT - SATURATED X'_d	0.2143	0.0158
SYNCHRONOUS - DIRECT AXIS X_d	2.3980	0.1768
SYNCHRONOUS - QUADRATURE AXIS X_q	1.2424	0.0916
NEGATIVE SEQUENCE X_2	0.1166	0.0086
ZERO SEQUENCE X_0	0.0095	0.0007

Time Constants	Seconds
OPEN CIRCUIT TRANSIENT - DIRECT AXIS T'_{d0}	2.2693
SHORT CIRCUIT TRANSIENT - DIRECT AXIS T'_d	0.2023
OPEN CIRCUIT SUBTRANSIENT - DIRECT AXIS T''_{d0}	0.0058
SHORT CIRCUIT SUBTRANSIENT - DIRECT AXIS T''_d	0.0050
OPEN CIRCUIT SUBTRANSIENT - QUADRATURE AXIS T''_{q0}	0.0048
SHORT CIRCUIT SUBTRANSIENT - QUADRATURE AXIS T''_q	0.0042
EXCITER TIME CONSTANT T_e	0.3600
ARMATURE SHORT CIRCUIT T_a	0.0361

Short Circuit Ratio: 0.5 Stator Resistance = 0.001 Ohms Field Resistance = 0.6165 Ohms

Voltage Regulation		Generator Excitation		
Voltage level adjustment: +/-	5.0%	No Load	Full Load, (rated) pf	
Voltage regulation, steady state: +/-	0.5%		Series	Parallel
Voltage regulation with 3% speed change: +/-	0.5%	Excitation voltage:	12.2 Volts	53.6 Volts Volts
Waveform deviation line - line, no load: less than	3.0%	Excitation current	1.3 Amps	4.6 Amps Amps
Telephone influence factor: less than	50			

[Top...](#)

Selected Model

Engine: 3516 **Generator Frame:** 1670 **Genset Rating (kW):** 2500.0 **Line Voltage:** 480
Fuel: Diesel **Generator Arrangement:** 5493798 **Genset Rating (kVA):** 3125.0 **Phase Voltage:** 277
Frequency: 60 **Excitation Type:** Permanent Magnet **Pwr. Factor:** 0.8 **Rated Current:** 3758.8
Duty: STANDBY **Connection:** SERIES STAR **Application:** EPG **Status:** Current
Version: 41205 /43061 /43741 /11996

Generator Mechanical Information

Center of Gravity		
Dimension X	-1117.6 mm	-44.0 IN.
Dimension Y	0 mm	0.0 IN.
Dimension Z	0 mm	0.0 IN.

- "X" is measured from driven end of generator and parallel to rotor. Towards engine fan is positive. See General Information for details
- "Y" is measured vertically from rotor center line. Up is positive.
- "Z" is measured to left and right of rotor center line. To the right is positive.

Generator WT = 4713 kg	* Rotor WT = 1710 kg	* Stator WT = 2326 kg
10,390 LB	3,770 LB	5,128 LB

Rotor Balance = 0.0508 mm deflection PTP
 Overspeed Capacity = 125% of synchronous speed

Generator Torsional Data

Generator Torsional Data						
J1	K1 = Shaft Stiffness between J1 + J2 (Diameter 1)		J2	K2 = Shaft Stiffness between J2 + J3 (Diameter 2)		J3
40.4 LB IN. s ²	0.0 MLB IN./rad	Min Shaft Dia 1	423.1 LB IN. s ²	0.0 MLB IN./rad	Min Shaft Dia 2	9.4 LB IN. s ²
4.57 N m s ²	0 MN m/rad	0 mm	47.8 N m s ²	0 MN m/rad	0 mm	1.06 N m s ²
Total J						
472.9 LB IN. s ²						
53.43 N m s ²						

[Top...](#)

Selected Model

Engine: 3516 **Generator Frame:** 1670 **Genset Rating (kW):** 2500.0 **Line Voltage:** 480
Fuel: Diesel **Generator Arrangement:** 5493798 **Genset Rating (kVA):** 3125.0 **Phase Voltage:** 277
Frequency: 60 **Excitation Type:** Permanent Magnet **Pwr. Factor:** 0.8 **Rated Current:** 3758.8
Duty: STANDBY **Connection:** SERIES STAR **Application:** EPG **Status:** Current
Version: 41205 /43061 /43741 /11996

Generator Cooling Requirements - Temperature - Insulation Data	
Cooling Requirements:	Temperature Data: (Ambient 40 °C)
Heat Dissipated: 96.1 kW	Stator Rise: 125 °C
Air Flow: 168 m ³ /min	Rotor Rise: 125 °C
Insulation Class: H	
Insulation Reg. as shipped: 100MΩ minimum at 40 °C	
Thermal Limits of Generator	
Frequency:	60 Hz
Line to Line Voltage:	480 Volts
B BR 80/40	2344 kVA
F BR -105/40	2844 kVA
H BR - 125/40	3125 kVA
F PR - 130/40	3125 kVA
H PR - 150/40	3385 kVA

[Top...](#)

Selected Model

Engine: 3516 **Generator Frame:** 1670 **Genset Rating (kW):** 2500.0 **Line Voltage:** 480
Fuel: Diesel **Generator Arrangement:** 5493798 **Genset Rating (kVA):** 3125.0 **Phase Voltage:** 277
Frequency: 60 **Excitation Type:** Permanent Magnet **Pwr. Factor:** 0.8 **Rated Current:** 3758.8
Duty: STANDBY **Connection:** SERIES STAR **Application:** EPG **Status:** Current
Version: 41205 /43061 /43741 /11996

Starting Capability & Current Decrement
Motor Starting Capability (0.4 pf)

SKVA	Percent Volt Dip
391	2.5
802	5.0
1,235	7.5
1,692	10.0
2,176	12.5
2,688	15.0
3,231	17.5
3,808	20.0
4,422	22.5
5,077	25.0
5,777	27.5
6,527	30.0
7,333	32.5
8,201	35.0
9,138	37.5
10,153	40.0

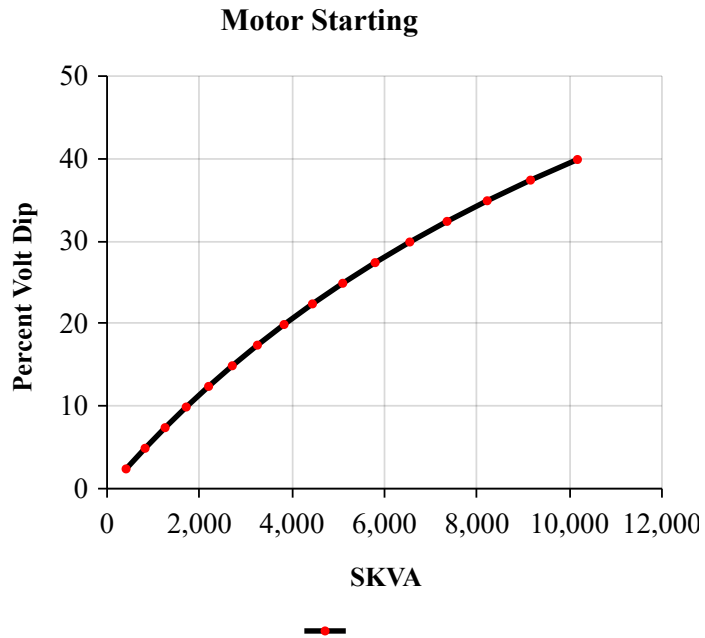

Current Decrement Data

E Time Cycle	AMP
0.0	29,684
1.0	16,800
2.0	15,218
3.0	14,149
4.0	13,179
5.0	12,286
7.5	10,350
10.0	8,775
12.5	7,534
15.0	7,244
20.0	7,673
25.0	8,476
30.0	9,421
35.0	10,128
40.0	10,413
45.0	10,544

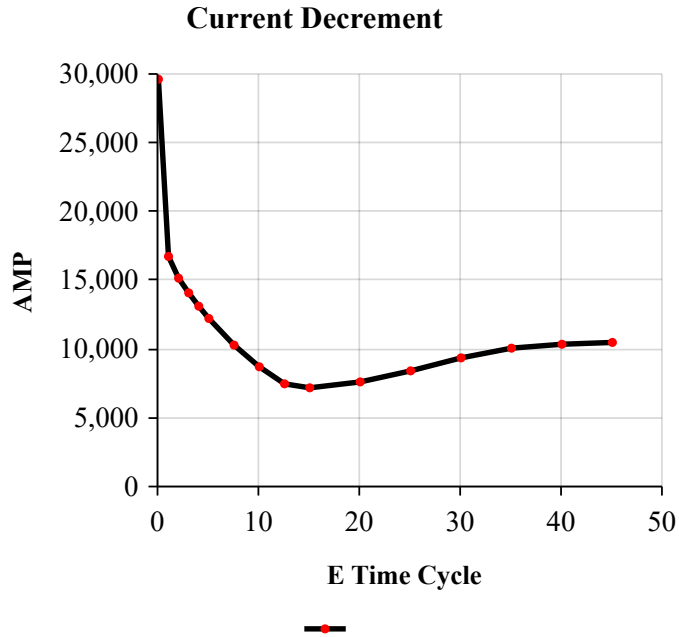

Instantaneous 3 Phase Fault Current: 29684 Amps Instantaneous Line - Line Fault Current: 26525 Amps
Instantaneous Line - Neutral Fault Current: 44149 Amps

[Top...](#)

Selected Model

Engine: 3516 **Generator Frame:** 1670 **Genset Rating (kW):** 2500.0 **Line Voltage:** 480
Fuel: Diesel **Generator Arrangement:** 5493798 **Genset Rating (kVA):** 3125.0 **Phase Voltage:** 277
Frequency: 60 **Excitation Type:** Permanent Magnet **Pwr. Factor:** 0.8 **Rated Current:** 3758.8
Duty: STANDBY **Connection:** SERIES STAR **Application:** EPG **Status:** Current
Version: 41205 /43061 /43741 /11996

Generator Output Characteristic Curves
Open Circuit Curve

Field Current	Line - Line Volt
0.0	0
27.0	288
31.9	336
37.3	384
43.8	432
52.5	480
65.8	528
88.5	576
130.8	624
213.6	672

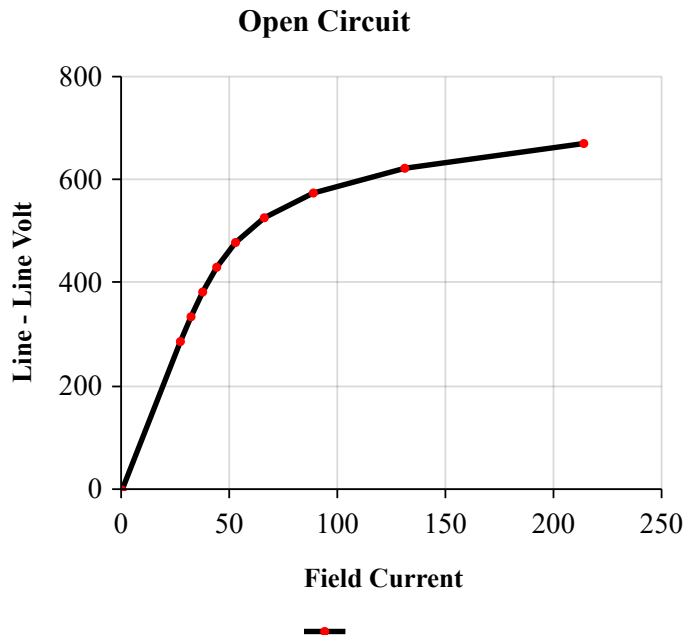

Short Circuit Curve

Short Circuit

Field Current	Armature Current
0.0	0
62.5	2,255
72.9	2,631
83.3	3,007
93.7	3,383
104.1	3,759
114.5	4,135
124.9	4,511
135.4	4,886
145.8	5,262

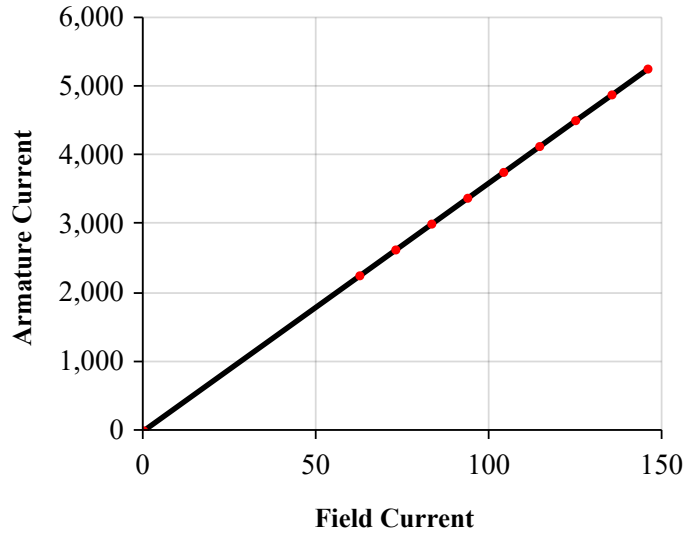

[Top...](#)

Selected Model

Engine: 3516 **Generator Frame:** 1670 **Genset Rating (kW):** 2500.0 **Line Voltage:** 480
Fuel: Diesel **Generator Arrangement:** 5493798 **Genset Rating (kVA):** 3125.0 **Phase Voltage:** 277
Frequency: 60 **Excitation Type:** Permanent Magnet **Pwr. Factor:** 0.8 **Rated Current:** 3758.8
Duty: STANDBY **Connection:** SERIES STAR **Application:** EPG **Status:** Current
Version: 41205 /43061 /43741 /11996

Generator Output Characteristic Curves
Zero Power Factor Curve

Zero Power

Field Current	Line - Line Volt
104.1	0
137.0	240
142.9	288
150.3	336
160.6	384
177.1	432
206.5	480
262.6	528
374.1	576
600.4	624

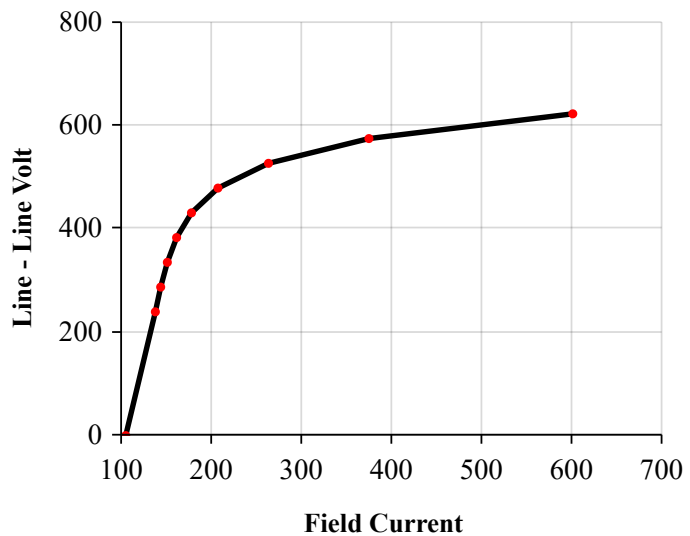

Air Gap Curve

Air Gap

Field Current	Line - Line Volt
0.0	0
26.6	288
31.0	336
35.4	384
39.8	432
44.3	480
48.7	528
53.1	576
57.5	624
62.0	672

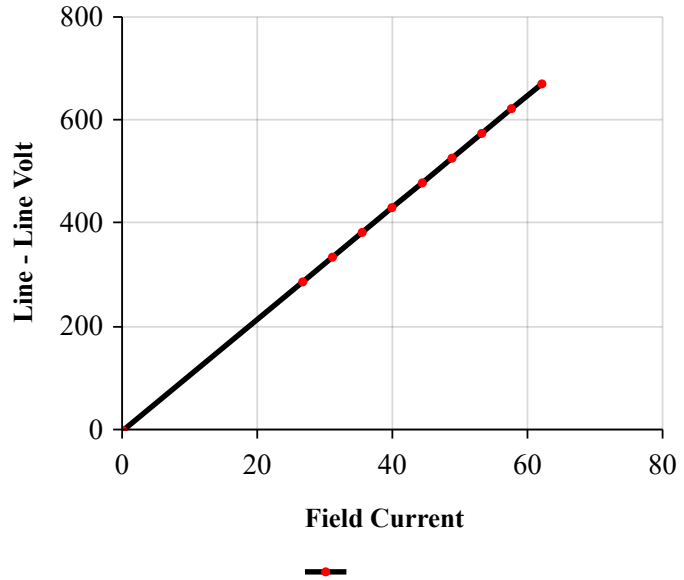

[Top...](#)

Selected Model

Engine: 3516	Generator Frame: 1670	Genset Rating (kW): 2500.0	Line Voltage: 480
Fuel: Diesel	Generator Arrangement: 5493798	Genset Rating (kVA): 3125.0	Phase Voltage: 277
Frequency: 60	Excitation Type: Permanent Magnet	Pwr. Factor: 0.8	Rated Current: 3758.8
Duty: STANDBY	Connection: SERIES STAR	Application: EPG	Status: Current
			Version: 41205 /43061 /43741 /11996

Reactive Capability Curve

Operating Chart

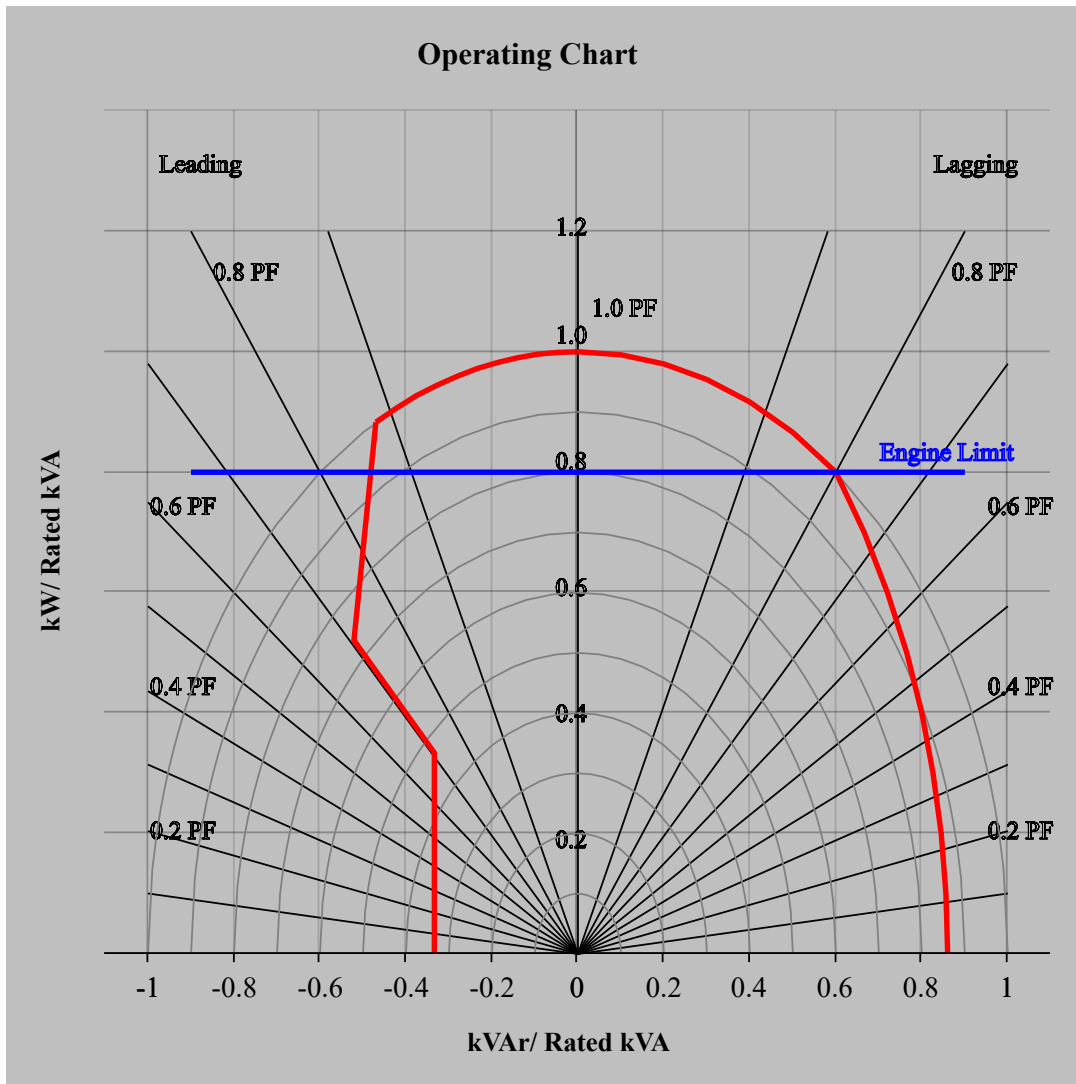

[Top...](#)

Selected Model

Engine: 3516	Generator Frame: 1670	Genset Rating (kW): 2500.0	Line Voltage: 480
Fuel: Diesel	Generator Arrangement: 5493798	Genset Rating (kVA): 3125.0	Phase Voltage: 277
Frequency: 60	Excitation Type: Permanent Magnet	Pwr. Factor: 0.8	Rated Current: 3758.8
Duty: STANDBY	Connection: SERIES STAR	Application: EPG	Status: Current
			Version: 41205 /43061 /43741 /11996

General Information

DM7825 Caterpillar SR5 Generators (50 Hz, 60 Hz)
 Data for 1400, 1600, 1700, 1800 and 1900 frames Caterpillar SR5
 generators built by Leroy Somer - USA and Leroy Somer ☐ France.

Refer to DM7821 for explanation of all generator data in Technical
 Marketing Information (TMI) except generator efficiency for which the
 explanation is given below.

GENERATOR EFFICIENCY

Generator efficiency is the percentage of engine flywheel (or other
 prime mover) power that is converted into electrical output. The
 generator efficiency shown is calculated by the summation of all
 losses method, and is determined in accordance with the IEC Standard
 60034. The efficiency considers only the generator. There is no
 consideration of engine or parasitic losses here.

Refer to DM7829 for low and medium voltage protective setting values and limits.

Caterpillar Confidential: **Green**

Content Owner: Commercial Processes Division

Web Master(s): [PSG Web Based Systems Support](#)

Current Date: 1/27/2026, 3:01:31 PM

© Caterpillar Inc. 2026 All Rights Reserved.

[Privacy](#).

[Cookie Settings](#)

CONFIDENTIAL AND NOT FOR DISTRIBUTION

Equipment included in the preliminary per unit offering is limited to the following Caterpillar C32B, 1500kW Stationary Emergency Standby* generator configuration:

1500kW electrical capacity, 60 Hz, 480VAC
Caterpillar SR5, 1447 Generator Frame, arrangement number 6301134
1500kW / 1875kVA rating at 0.8 PF
125C Temp Rise over 40C Ambient
Permanent magnet excitation
Alternator Space Heater
Caterpillar ECS 100 Control Panel
Remote Annunciator (quantity 1)
Caterpillar ADEM A5 Engine Governor
Caterpillar Integrated Voltage Regulator
Ethernet Communications utilizing Modbus TCP/IP protocol

Engine Accessories include:

Caterpillar cooling system with 116F ambient temperature capability and engine driven radiator fan
Caterpillar heavy duty dual-element engine air filter
Dual electric starting motors
Jacketwater heater
Engine coolant
Engine oil
Seismic vibration isolators

Electrical accessories include:

Right side, Masterpact 2500 Amp, 3-pole, electrically operated circuit breaker with LSIG-P electronic trip unit.
Bottom Cable Entry

Additional listings, certifications and test reports included with configuration:

Caterpillar seismic certification
Alternator Test Report
Standard Engine Test Report
Standard Torsional Vibration Analysis Report
Generator Package Test Report @ 0.8 PF (manufacturer's standard production test)**

* Caterpillar's C32B, 1500kW generator set is not currently available with a Mission Critical Standby rating. The Stationary Emergency Standby offering is suitable for a standby application supporting administrative loads but is otherwise inconsistent with the "Data Center Continuous" language included in the Day 1 LV Generator Specifications.

** Manufacturer's unit test's do not comply in total with specified FAT test procedures. Provisions to support additional test requirements identified in the FAT specifications will require further review in order to provide a commercial response.

Cat® C32B

Diesel Generator Sets



Image shown may not reflect actual configuration

Bore – mm (in)	145 (5.7)
Stroke – mm (in)	162 (6.4)
Displacement – L (in ³)	32.1 (1959)
Compression Ratio	14.0:1
Aspiration	TA
Fuel System	EUI
Governor Type	ADEM™ A5

Model	Standby / Mission Critical 60 Hz ekW (kVA)	Emissions Performance
D1500	1500 (1875)	U.S. EPA Emergency Stationary (Tier 2)

Standard Features

Cat® Diesel Engine

- Designed and tested to meet the U.S. EPA Emergency Stationary Use Only (Tier 2) emission standards
- Reliable and consistent performance proven in thousands of applications worldwide

Generator Set Package

- Accepts 100% block load and meets NFPA 110 loading requirements
- Conforms to ISO 8528-5 G2 load acceptance requirements
- Reliability is verified through prototype testing, which includes torsional vibration, fuel consumption, oil consumption, transient performance, and endurance testing

Alternators

- Superior motor starting capability minimizes the need for oversizing the generator
- Designed to match the performance and output characteristics of Cat diesel engines

Cooling System

- Cooling systems available to operate in ambient temperatures up to 50°C (122°F)
- Tested to ensure proper generator set cooling

Cat Energy Control System (ECS) / GCCP

- User-friendly interface and navigation
- Scalable system to meet a wide range of installation requirements
- Expansion modules and site specific programming for specific customer requirements with graphical touchscreen display
- Easily upgradable

Warranty

- 24 months/1000-hour warranty
- 5 years Platinum Complimentary Extended Service Coverage

Worldwide Product Support

- Cat dealers have over 1,800 dealer branch stores operating in 200 countries
- Your local Cat dealer provides extensive post-sale support, including maintenance and repair agreements

Financing

- Caterpillar offers an array of financial products to help you succeed through financial service excellence
- Options include loans, finance lease, operating lease, working capital, and revolving line of credit
- Contact your local Cat dealer for availability in your region

Standard and Optional Equipment

Engine

Air Cleaner

- Single element
- Dual element

Starting

- Standard batteries
- Standard electric starter
- Jacket water heater

Alternator

Output voltage

- 480V
- 600V
- 2400V
- 4160V

Temperature Rise (over 40°C ambient)

- 125°C
- 105°C

Winding type

- Random wound
- Form wound

Excitation

- Permanent magnet (PM)

Attachments

- Anti-condensation heater
- Stator and bearing temperature monitoring and protection

Power Termination

Type

- Bus bar
- Circuit breaker
- 400A 800A
- 1200A 1600A
- 2000A 2500A
- 3000A 3200A
- UL IEC
- 3-pole 4-pole
- Manually operated
- Electrically operated

Trip Unit

- LSI LSI-G
- LSI-G-P

Control System

Controller

- GCCP 1.2
- CAT® ECS 100 and CAT® ECS 200

Attachments

- Local annunciator module
- Remote annunciator module
- Expansion I/O module
- Remote monitoring software

Charging

- Battery charger - 10A
- Battery charger - 20A
- Battery charger - 40A

Vibration Isolators

- Rubber
- Spring
- Seismic rated

Cat® Connect

Connectivity

- Ethernet
- Cellular

Extended Service Options

Terms

- 2 years
- 3 years
- 5 years (Complimentary)
- 10 years

Coverage

- Silver
- Gold
- Platinum (Complimentary)
- Platinum Plus

Ancillary Equipment

- Automatic transfer switch (ATS)
- Uninterruptible power supply (UPS)
- Paralleling switchgear
- Paralleling controls

Certifications

- UL 2200 Listed
- IBC seismic certification
- OSHPD pre-approval

Note: Some options may not be available on all models. Certifications may not be available with all model configurations. Consult factory for availability.

Package Performance

Performance	Standby / Mission Critical	
Frequency	60 Hz	
Genset power rating with fan	1500 ekW	
Genset power rating with fan @ 0.8 pf	1875 kVA	
Emissions	EPA (Tier 2)	
Performance number	EM7357 / EM7410	
Fuel Consumption		
100% load with fan – L/hr (gal/hr)	385.9	(101.9)
75% load with fan – L/hr (gal/hr)	309.8	(81.8)
50% load with fan – L/hr (gal/hr)	222.2	(58.7)
25% load with fan – L/hr (gal/hr)	125.4	(33.1)
Cooling System		
Radiator air flow restriction (system) – kPa (in. water)	0.12	(0.48)
Radiator air flow – m ³ /min (CFM)	1385	(48911)
Engine coolant capacity – L (gal)	55	(14.5)
Radiator coolant capacity – L (gal)	109	(28.8)
Total coolant capacity – L (gal)	164	(43.3)
Inlet Air		
Combustion air inlet flow rate – m ³ /min (CFM)	121.9	(4302.9)
Exhaust System		
Exhaust stack gas temperature – °C (°F)	458.6	(857.5)
Exhaust gas flow rate – m ³ /min (CFM)	317.1	(11198.4)
Exhaust system backpressure (maximum allowable) – kPa (in. water)	6.7	(27.0)
Heat Rejection		
Heat rejection to jacket water – kW (BTU/min)	459	(26109)
Heat rejection to exhaust (total) – kW (BTU/min)	1403	(79792)
Heat rejection to aftercooler – kW (BTU/min)	490	(27853)
Heat rejection to atmosphere from engine – kW (BTU/min)	265	(15093)
Heat rejection from alternator – kW (BTU/min)	79	(4492)
Emissions* (Nominal)		
NOx mg/Nm ³ (g/hp-h)	2844.1	(5.87)
CO mg/Nm ³ (g/hp-h)	82.0	(0.19)
HC mg/Nm ³ (g/hp-h)	42.4	(0.10)
PM mg/Nm ³ (g/hp-h)	5.7	(0.02)
Emissions* (Potential Site Variation)		
NOx mg/Nm ³ (g/hp-h)	3441.4	(7.11)
CO mg/Nm ³ (g/hp-h)	153.3	(0.35)
HC mg/Nm ³ (g/hp-h)	80.1	(0.19)
PM mg/Nm ³ (g/hp-h)	11.2	(0.03)

*mg/Nm³ levels are corrected to 5% O₂. Contact your local Cat dealer for further information.



Image Shown may not Reflect Actual Package.

SR5 — 1400 Frame

Standby Power

50 Hz, 1500 rpm 840 – 1590 kVA
 60 Hz, 1800 rpm 840 – 1590 ekW

Prime Power

50 Hz, 1500 rpm 840 – 1500 kVA
 60 Hz, 1800 rpm 840 – 1500 ekW

Continuous Power

50 Hz, 1500 rpm 840 – 1500 kVA
 60 Hz, 1800 rpm 840 – 1500 ekW

Features

General

- Standards: meets the requirements of NEMA,
- IEC, ISO, IEEE, BS, AS
- Industry leading insulation technology
- Proven mechanical and electrical design
- Reliable and durable construction
- Improved excitation system for high power quality
- Improved motor starting capability
- Radio frequency noise suppression better than industry standards
- Superior construction and testing

Standard

- 3 phase brushless, salient pole
- NEMA Class H insulation
- Class H Temperature rise at 40°C ambient
- 2/3 winding pitch
- Low voltage: Random Wound and Internal
- Excitation
- Medium voltage: Form Wound and Permanent Magnet
- Standard voltages:
 - 60 Hz: 480V, 4160V
 - 50 Hz: 400V, 3300V
- Busbar connections:
 - 60 Hz models: NEMA standard hole pattern
 - 50 Hz models: IEC standard hole pattern

Optional

- PM excitation capability to IE excitation
- Low Voltage: Form Wound
- Space heater kit
- Bearing temperature detectors
- Optional voltages:
 - 60 Hz: 380V, 440V, 600V, 2400V
 - 50 Hz: 380V, 415V
- Oversized generators for Class F or Class B temperature rise
- UL Listing
- CSA test and certification

NEMA MG-1 Temperature Rise

(Over 40°C ambient)

	Class A	Class B	Class F	Class H
Standby	85°C	105°C	130°C	150°C
Prime / Continuous	60°C	80°C	105°C	125°C

Specification

Type

Brushless, revolving field solid-state automatic voltage regulator

Construction

One bearing 3 phase, series star connected

Enclosure

Drip proof IP23, guarded

Alignment

Cat® pilot shaft, single bearing only

Over-speed capability

60 Hz — 125% of synchronous speed

50 Hz — 150% of synchronous speed

Waveform deviation, line to line, no load

Less than 2%

Paralleling capability

Standard with adjustable voltage droop

Voltage regulator

3 Phase sensing with variable Volts-Per Hertz response

Voltage regulation, steady state

+/- 0.5%

Voltage regulation with 3% speed change

+/- 0.5%

Voltage gain

Adjustable to compensate for engine speed droop and line loss

Number of leads

6

Product Support

- Standard Caterpillar warranty
- Optional extended Caterpillar warranty
- Serviceable parts available through Caterpillar Parts System
- Service intervals agree with recommended engine practices

Serviceability

- Stator leads exit top
- Replaceable bearing sleeve(s) for longer life and lower repair cost
- Easy access to serviceable parts
- Improved wire and terminal identification ensuring reliable connection

Cable Entry

- Top cable entry on LV package
- Bottom cable entry on MV package

Main Stator Construction

The 1400 frame generators use Round lamination stator design.

Stator coil pitch, coil distribution designed to produce optimum waveform and minimum total harmonic distortion. Stator slots are insulated by slot liners and coil separators. Slot liners, coil separators, and top sticks provide a minimum of 25 mm (1 in) distance from the coil to ground. The thickness of liners, separators, and phase sheets provides superior protection between phases and ground.

Low voltage stator windings are given a 3000 volt "high pot" test (150% of the NEMA and IEC requirements for 460 volt generators) before the insulation is applied. The stators are then given a vacuum impregnation treatment of polyester material, followed by an application of epoxy 2000 volt "high pot" test.

Rotor Construction

The main rotor is constructed using a precision "wet" layer winding process with epoxy painted on the bare rotor and on each layer. This ensures bonding of all the wire layers together, bonding of the coils to the rotor laminations, and a sealed insulation system. The rotor is put in the oven for curing the epoxy.

The exciter rotor is machine wound and receives a trickle coat of a fungus-resisting resin. Numerically controlled turning and grinding machines produce rotor shafts with close repeatable tolerances. Grade-8 bolts are used wherever joints are subject to induced stresses. A complete coating of red sealer is applied to protect the rotors and shaft from corrosion.

Every production rotor is dynamically balanced peak-to-peak amplitude and run at rated speed before assembly into the stator.

Information contained in this publication may be considered confidential. Discretion is recommended when distributing. Materials and specifications are subject to change without notice.

CAT, CATERPILLAR, LET'S DO THE WORK, their respective logos, "Caterpillar Corporate Yellow", the "Power Edge" and Cat "Modern Hex" trade dress as well as corporate and product identity used herein, are trademarks of Caterpillar and may not be used without permission.



Image shown may not reflect actual configuration.

Cat® Energy Control System (ECS) 100

The Cat ECS 100 generator set controller uses system graphic icons and labels that allow for simple, comprehensive generator set operation. The easy-to-use 203 mm (8") color LED touchscreen display features scroll navigation. Generator set and remote-mount options are available.

FEATURES

- Island mode – single unit operation
- High visibility graphical touchscreen display with alarm/event descriptions, set points, engine and generator monitoring
- Meets UL 2200, 3rd Edition requirements including UL 6200
- Local annunciation to meet NFPA 110 (subject to local authority having jurisdiction approval)
- Ethernet Modbus TCP for external communications
- Intuitive navigation for display of power metering, protection, engine and generator parameters and tuning
- Lockout security provision to assure platform integrity with three programmable security levels
- Support of up to four (4) remote HMI's (sold separately)
- Multi-language support.
- Compatible with Cat Connect Product Link™ devices
- IVR or CDVR voltage regulation compatibility
- Emergency Override

Advanced Functionality

- Automatic mains failure with utility voltage sensing capability (open transition) and remote breaker or contactor control/monitoring
- Engine remote start integrity monitoring
- Single genset transient load relief (TLR)
- Basic programmable logic control (PLC) function
- Embedded webserver
- EPA Tier 4 integration
- Real (kW) load histograms
- Status event log
- Supports Dynamic Gas Blending™ (DGB™)

Control Module and Display

The Cat A6L3 is the base module controller utilizing the high-resolution display for the human machine interface (HMI).

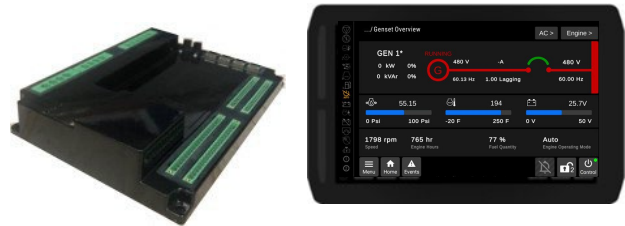

Typical⁽¹⁾ Single Line Diagram (SLD)

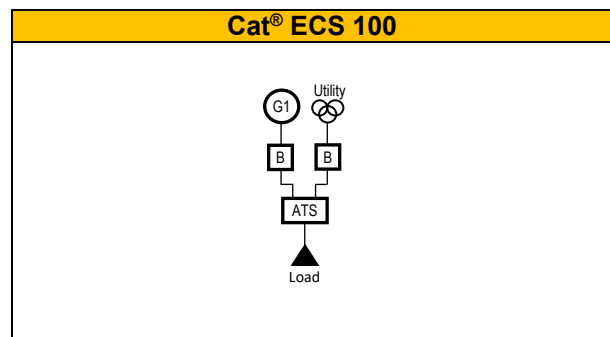

⁽¹⁾ - More single line diagrams (SLD's) are available to meet application requirements. Contact your local Cat dealer for more information.

Standard Features

Controls	<ul style="list-style-type: none"> • Auto / Start / Stop • Emergency stop • Engine cooldown timer • Engine cycle crank • Programmable cycle timer • Speed and voltage adjust
Generator Set Monitoring	<ul style="list-style-type: none"> • Generator AC voltage monitoring (+/- 0.25% controller lifetime accuracy) • Utility/Bus AC voltage monitoring (+/- 0.25% controller lifetime accuracy) • 3 phase/4 wire (L-L&L-N) sensing • Current sensing (3 phase/6 wire) (+/- 0.1% up to 100% of rated current controller accuracy) • Generator AC current (per phase & avg) • Generator frequency • Power metering (kW, kVA, kVA_r, pf) • kW-hr (export), kVA_r-hr (import and export), total and trip • Generator stator and bearing temp (with optional RTD module) • kW load histogram
Generator Protection	<ul style="list-style-type: none"> • Generator phase sequence (47G) • Over/Under voltage (27/59) • Over/Under frequency (81 O/U) • Overcurrent timed & inverse (50/51) • Overcurrent (Thermal Damage Curve) (51) • Reverse power real (kW) (32) • Reverse power reactive (kVA_r) (32RV) • Current balance (46) • Overload (49)
Engine Monitoring	<ul style="list-style-type: none"> • Engine oil pressure (kPa or psi) • Engine oil temperature (°C or °F) • Engine coolant temperature (°C or °F) • Engine speed (RPM) • Battery voltage • Crank attempt and successful start counter • Run hour meter • Real time clock
Engine Protection	<ul style="list-style-type: none"> • Control switch not in auto (alarm) • Low oil pressure • High coolant temperature (alarm and shutdown) • Low coolant temp (alarm) • Low coolant level (alarm and shutdown) • High engine oil temp (alarm and shutdown) • Low/High/Weak battery voltage • Fail to start • Overspeed • Overcrank • Low gas pressure (alarm and shutdown)

Standard Features *(continued)*

Digital Inputs	<ul style="list-style-type: none"> • Emergency Stop • Remote Start • 16 programmable inputs (4 used for functional safety)⁽²⁾
Digital Outputs	<ul style="list-style-type: none"> • 12 programmable outputs (4 used for functional safety)⁽²⁾
Analog Outputs	<ul style="list-style-type: none"> • 2 analog outputs
PWM Outputs	<ul style="list-style-type: none"> • 3 Total (1 used for IVR - standard)
Analog Inputs	<ul style="list-style-type: none"> • 3 programmable inputs (0-5V, 0.5-4.5V, 1-5V, or resistive)⁽²⁾
Communication	<ul style="list-style-type: none"> • Primary & accessory CAN data link • Remote annunciator data link up to 1219 m (4000 ft) • Cat[®] Data Link (CDL) - with optional PLE702 • Ethernet (Modbus TCP/IP) - 100 baseT • USB- touchscreen display • Four 4-wire ports for internal and customer use • Two 2-wire ports for internal device network
Environmental	<ul style="list-style-type: none"> • HMI (front touchscreen) IP66 • A6L3 Controller Operating Temp. -40°C to + 70°C • Control module box: <ul style="list-style-type: none"> - Ingress protection IP23 - Health Care Access and Information (HCAI) ground and roof seismic certification
Languages	<ul style="list-style-type: none"> • Chinese Danish English French German Italian Japanese Portuguese Russian Spanish additional languages on request

⁽²⁾ - Generator set configuration may affect available features.

Enhanced Control Features

Advanced overcurrent protection

The Cat ECS 100 provides advanced overcurrent protection of the generator set system via programmable Definite Time and Inverse Time curves.

For the Inverse time curve the following four selections are available:

- Normally Inverse
- Very Inverse
- Extremely Inverse
- Thermal Damage Curve - the Thermal Damage curve may be more closely aligned to specific generators.

Arc Flash Maintenance mode

The Cat ECS 100 Programmable Arc Flash Energy Reducing Maintenance Mode feature provides a method to reduce clearing time via two functions that work together to meet the 2023 edition of NFPA 70, Section 240.87 (Arc Energy Reduction).

- A means to accept an energy-reducing maintenance switch and provide means to connect a local status indicator.
- An instantaneous overcurrent setting that can be set below the available arcing current.

Integrated programmable logic controller (PLC)

This feature set of the Cat ECS 100 allows the user to create custom logic functions in similar fashion to that of the capability of a PLC controller. These logic functions allow for increased capability of the Cat ECS 100 through interaction and control of internal signals within the control software as well as the programmable inputs/outputs of the device.

Programmable kW relay

The Cat ECS 100 includes three programmable kW relay outputs configured based on the % kW of the generator set. The configurable set points of the kW relay include: trigger condition, percentage threshold, hysteresis percentage and trip activation & deactivation delay time. These output functions may also be used to trigger events, recordable within the event log and included in the remote monitoring of the generator set.

Real-time clock

The real-time clock allows for date and time stamping of diagnostics and events in the control's logs as well as service maintenance reminders based on engine operating hours or calendar days.

Diagnostic System and Status Event Logs

Up to 40 unique diagnostic events (e.g., warnings, shutdowns, etc.) are stored in the non-volatile memory. It also allows for the creation of a status event log. This log holds the last 500 control events such as Engine Control Switch Position, Remote Initiate, Load Shed, etc. Events are stored in a "first in, first out" strategy.

Programmable cycle timer

The programmable cycle timer (PCT) feature allows for programming of seven independent times, when tasks (called PCT outputs), will be activated or deactivated automatically during the week. This is useful for exercising generator sets, or cases where two or more generators are required to automatically share the duty of supplying a load throughout the week. Using the PCT, each generator set can be programmed to start and stop at pre-set times. The PCT can handle a seven-day sequence with seven independent starts happening one or more times each week. Each of the seven timers has the following set points: activation day of the week, activation start time, active time and includes three (3) independent activation outputs.

Real (kW) load histogram

The Cat ECS 100 is equipped with a real (kW) load histogram. This feature keeps track of the amount of time the generator percent kW is within certain predefined ranges. The ranges monitored are in 10% steps (0 to <10%, 10% to <20%, ..., 90% to 100%).

HMI Webserver

The Cat ECS 100 HMIs include an embedded web server. The embedded web server allows the operator to operate a virtual HMI with the same control and permissions as the host HMI (local or remote, if applicable) over an Ethernet connection to a local and/or remote station. Custom screen creation is also available. Each HMI webserver is independent.

Optional Modules

Off Package HMI

The Cat ECS 100 supports up to four (4) optional full function off package HMI displays with the addition of an unmanaged Ethernet switch. The interactive 203 mm (8") color touchscreen graphical interface serves to display generator set system alarm conditions, status indications and annunciation (with RCA output) to meet NFPA110 (subject to local authority having jurisdiction approval).

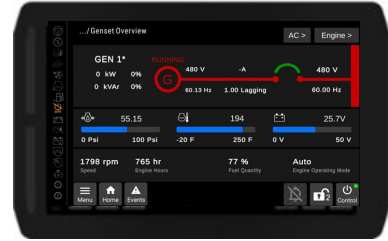

RS-485 Remote Annunciator

The remote RS-485 annunciator serves to display genset system alarm conditions and status indications for 16 points with a standard NFPA 99 & 110 label. The annunciator has been designed for use on the long-distance annunciator datalink and may be used off package up to 1220m (4000 feet) applications. A maximum of four (4) annunciators may be used with a Cat ECS 100.

See LEHE21395.



Expansion Input/Output Ethernet Modules

- Supports expanded Inputs/Outputs (IO) capability of the Cat ECS 100 control:
 - Analog & digital I/O
 - Temperature sensing (RTD)
- Configure I/O for any event (read & write function)
- Package mounted and/or ship loose options

See LEHE22466

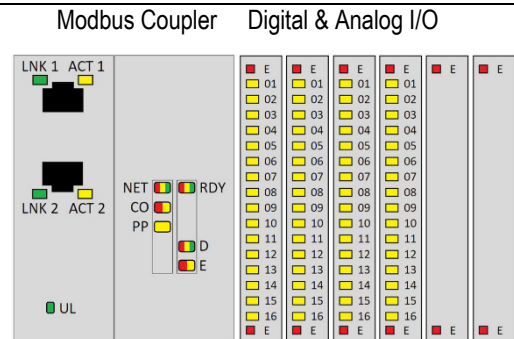

Optional Modules(*continued*)

Digital Input/Output Module

The Digital Input/Output (DI/O) module serves to provide expandable Input and Output for any event and is capable of reading 12 discrete inputs to trigger system events and setting 8 relay outputs based on system events. The DI/O module has been designed for use on the accessory communication network and may be used in either local (package mounted) or off package up to 244 m (800 feet) applications. A maximum of four DI/O modules may be used with a Cat ECS 100.



See LEHE21394

RTD Module

The RTD module serves to provide expandable generator temperature monitoring capability of the Cat ECS 100 control system and is capable of reading up to eight 2-wire, 3-wire and 4-wire RTD inputs. The RTD Module has been designed for use on the accessory communication network and may be used in either local (package mounted) or off package up to 244 m (800 feet) applications. A maximum of one RTD Module may be used with a Cat ECS 100.



See LEHE21396

Dimensions

Package-Mounted or Ship Loose (with harness)

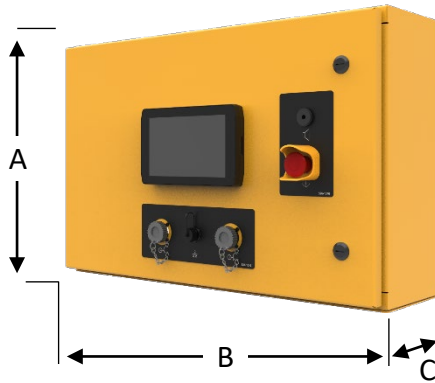

Image shown may not reflect actual configuration.

Dimensions				
Control Box Dimensions	A	B	C ⁽³⁾	Weight
Units	mm (in)	mm (in)	mm (in)	kg (lbs)
Cat ECS 100	515 (20.28)	794 (31.27)	273 (10.73)	43 (95)

⁽³⁾ - Dimension including E-Stop button is 263 mm (10.35 in).

Worldwide Product Support

Cat dealers have over 1,800 dealer branch stores operating in 200 countries and offer extensive post-sale support including maintenance and repair agreements

Materials and specifications are subject to change without notice.
The International System of Units (SI) is used in this publication.

© 2024 Caterpillar. All Rights Reserved. CAT, CATERPILLAR, LET'S DO THE WORK, their respective logos, "Caterpillar Corporate Yellow", the "Power Edge" and Cat "Modern Hex" trade dress as well as corporate and product identity used herein, are trademarks of Caterpillar and may not be used without permission.

www.cat.com/electricpower

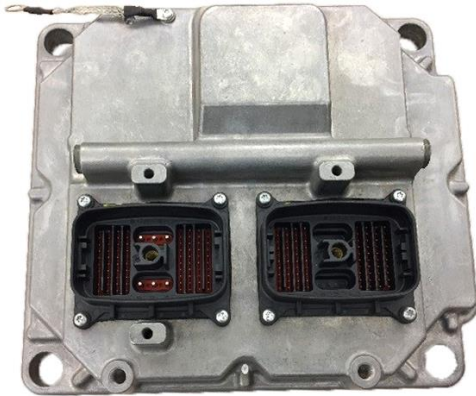

Picture shown may not reflect actual configuration

ADEM™ A5 Engine Controller

The ADEM A5 is the main Electronic Control Module (ECM) used on select diesel engines. This electronic control unit has been developed around high-speed Power PC technology to offer a configurable, rugged control. The ADEM A5 provides a higher degree of control over a large number of combustion variables. The ADEM A5 is designed to control/ interface Electronic Unit Injector (EUI) equipped engines. The ADEM A5 engine system is composed of the ADEM A5 ECM, control software, sensors, actuators, fuel injectors, and interface to the generator system. The prime benefit of an ADEM A5 engine system is to better control and maintain the particulate emissions, both steady state and transient, while improving engine performance.

FEATURES

RELIABLE AND DURABLE

- All ADEM A5 controllers are designed to survive the harshest environments.
- Environmentally sealed, die-cast aluminum housing isolates and protects electronic components from moisture and dirt contamination.
- Rigorous vibration testing ensures product reliability and durability.
- Programmable dither period and amplitude
- Configurable Analog inputs
- Programmable current control
- NVSRAM Support
- 4-20mA Current Input and output capability.
- Accuracy maintained from -40° C to 85° C
- Electrical noise immunity to 100 volts/meter
- Internal circuits are designed to withstand shorts to +battery and -battery.
- Built-in fault detection and diagnostics
- Support J1939 (CAN), CDL, ATA

SIMPLE SERVICING

- Each ADEM A5 system works in combination with the Cat® ET service tool software to keep the engine operating at peak performance.
- Displays measured parameters
- Retrieves active and logged event code documenting abnormal system operation
- Performs calibrations and diagnostic tests
- Supports flash programming of new software into the ADEM A5 ECM

ELF DIAGNOSTICS

- Each ADEM A5 ECM has a full complement of diagnostics. The ECM can detect faults in the electrical system and report those faults to the service technician for quick repair.
- Self-diagnostic capability pinpoints operational problems in need of attention.

ADVANCED FEATURES

- Enhanced performance from fuel injection timing and limiting
- Adjustable monitoring of vital engine parameters
- Programmable speed acceleration ramp rate
- Data link interfaces

DESCRIPTION

The ECM is housed in an environmentally sealed casting. All wiring connections to the ECM are made using two sealed connectors: a single eighty six pin connector and a single eighty pin connector.

ENGINE SPEED GOVERNING

Desired engine speed is calculated by the ECM and held within ± 0.2 Hz for isochronous and droop mode. The ECM accounts for droop that is requested.

The proper amount of fuel is sent to the injectors due to these calculations.

The ECM also employs cooldown/ shutdown strategies, acceleration delays on startup, acceleration ramp times and speed reference.

FUEL LIMITING

Warm and cold fuel-air ratio control limits are controlled by the ECM.

Electronic monitoring system derates, torque limit, and cranking limit, programmable torque scaling, and cold cylinder cutout mode are standard features.

FUEL INJECTION TIMING

Master timing for injection is controlled by the ECM control.

Temperature dependencies are accounted for in the fuel injection calculations.

ELECTRONIC MONITORING

Electronic monitoring of vital engine parameters can be programmed.

Warning, derate, and shutdown event conditions may be customized by the user.

INFORMATION MANAGEMENT

The ECM stores information to assist with electronic troubleshooting.

Active and logged diagnostic codes, active events, logged events, fuel consumption, engine hours, and instantaneous totals aid service technicians when diagnosing electronic faults and scheduling preventive maintenance.

CALIBRATIONS

Engine performance is optimized through injection timing.

Auto/manual sensor calibrations are standard features.

ON-BOARD SYSTEM TESTS

System tests are available to assist in electronic troubleshooting.

These tests include: injector activation, injector cutout, and override of control outputs.

DATA LINK INTERFACES

The ADEM A5 communicates with the EMCP via a dedicated communication network.

ELECTRONIC SENSING

The following sensing is available on the ADEM A5: oil pressure, fuel pressure, fuel temperature, atmospheric pressure, air inlet temperature, turbo outlet pressure, engine coolant temperature, engine speed, throttle, position, exhaust temperature, oil filter pressure differential, fuel filter pressure differential, air filter pressure differential and crankcase pressure.

SPECIFICATIONS

- Housing: Die-cast aluminum
- Impervious to: salt spray, fuel, oil and oil additives, coolant, spray cleaners, and dust
- Input and output protection all inputs and outputs are protected against short circuits to +battery and -battery
- Input voltage range (24 VDC nominal) 18 to 32 VDC
 - (note ECM is capable of 12 & 24C so range is really 9 - 32)
- Mounting - engine mounted
- Reverse polarity protected
- Shock, withstands 20 g Temperature range:
 - Operating: -40°C to $+85^{\circ}\text{C}$ (-40°F to $+185^{\circ}\text{F}$)
 - Storage: -50°C to $+120^{\circ}\text{C}$ (-58°F to $+248^{\circ}\text{F}$)
- Vibration withstands 8.0 g @ 24 to 2 kHz
- Maximum Average Operating Current (LoadSpecific) 38.25Arms

PROCESSING ELEMENTS

- Microprocessor: MPC5674F
- Processor Speed: 264 MHz
- Flash ROM: 4 MB
- SRAM – internal: 256 KB
- SRAM – external: 1024 / 512 kB
- ADC: 10 bit
- EEPROM: 64KB

GENERAL DRAWING

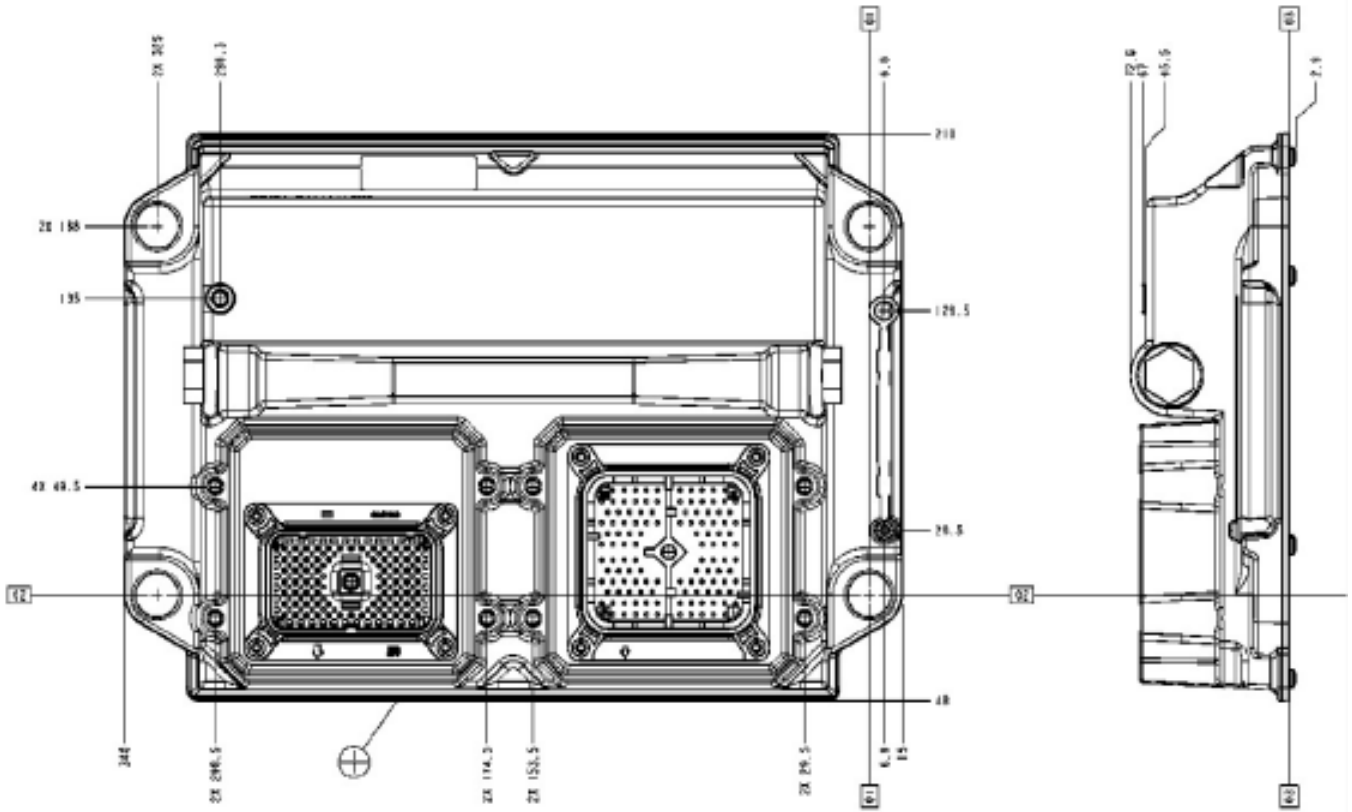

Length: 355 mm (14.0")
 Height: 288 mm (11.3")
 Width: 66.5 mm (2.6")
 Weight: 3.34 kg (7.36 lbs.)

Materials and specifications are subject to change without notice.
 CAT, CATERPILLAR, their respective logos, "Caterpillar Yellow," the "Power Edge" trade dress as well as corporate and product identity used herein, are trademarks of Caterpillar and may not be used without permission

<http://www.cat.com/powergeneration>

©2018 Caterpillar
 All rights reserved.

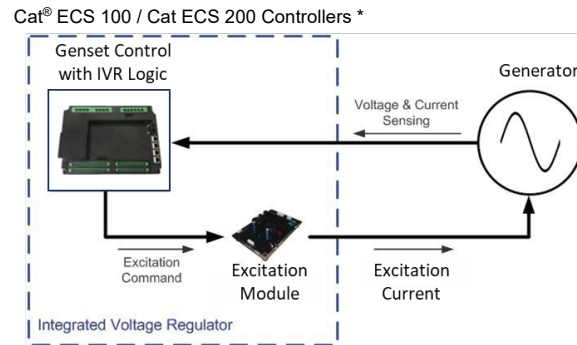
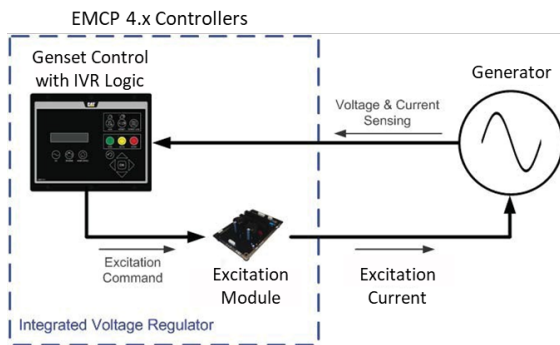

* Cat® Energy Control System (Cat ECS)

INTEGRATED VOLTAGE REGULATOR

The Integrated Voltage Regulator (IVR) is designed to provide robust, precise closed-loop control of the generator voltage, optimized transient performance and industry leading feature specification.

Caterpillar is leading the power generation marketplace with power solutions engineered to deliver unmatched flexibility, expandability, reliability, and cost-effectiveness.

FEATURES

When used with an Excitation Module, EMCP 4.3/4.4 and IVR-compatible EMCP 4.1/4.2 (B), and Cat ECS 100 / Cat ECS 200 controllers offers:

- Automatic Voltage Regulation (AVR)
- Programmable stability settings
- Soft start control with an adjustable time setting in AVR control mode
- Dual Slope, Configurable Under Frequency (Volts/Hz) regulation
- Three-phase or single-phase generator voltage (RMS) sensing/regulation in AVR mode
- Setpoint adjustment from the EMCP / Cat ECS display or Cat ET Service Tool
- IVR Operating Status and Voltage Bias Overview screens to provide an enhanced level of user interface
- Integrated Voltage Regulator event monitoring

EMCP 4.3/4.4 and IVR-compatible EMCP 4.2 (B), and Cat ECS 100 / Cat ECS 200 controllers also offer:

- Power Factor Regulation (PF)
- Reactive Droop compensation
- Line drop compensation

WORLDWIDE PRODUCT SUPPORT

- Worldwide parts availability through the Cat dealer network
- Over 1,800 dealer branch stores operating in 200 countries
- The best product support record in the industry
- Cat dealers provide extensive post sale support including maintenance and repair agreements

COMPLETE SYSTEM INTEGRATION

Fully designed and factory tested to work seamlessly with Cat generators using Self Excitation (SE), Internal Excitation (IE) or Permanent Magnet (PMG) excitation systems and EMCP and Cat ECS controls.

INTEGRATED VOLTAGE REGULATOR FEATURE SPECIFICATION

SPECIFICATIONS					
No Load to Full Load Regulation	±0.5%	±0.25%	±0.25%	±0.25%	±0.25%
Configurable Volts / Hz Characteristic	•	•	•	•	•
Configurable Knee Frequency	•	•	•	•	•
Regulator Response Time	10 ms	10 ms	5 ms	5 ms	5 ms
Single and Three Phase Sensing	•	•	•	•	•
Voltage Adjustment Range	± 30%	± 30%	± 30%	± 30%	± 100%
CONTROL					
Characteristic	•	•	•	•	•
Excitation Enable Disable Selection	•	•	•	•	•
Line Loss (I ² R) Compensation	–	•	•	•	•
Reactive Droop Compensation	–	•	•	•	•
Power Factor Control Mode	–	•	•	•	•
PROTECTION ALARMS					
Generator Overvoltage	•	•	•	•	•
Generator Under voltage	•	•	•	•	•
Over Excitation	•	•	•	•	•
Loss of Sensing	•	•	•	•	•
Generator Reverse VARs	–	•	•	•	•
Event Log	•	•	•	•	•
METERING					
AC Metering	•	•	•	•	•
Power Metering	–	•	•	•	•
Excitation Command Percentage	•	•	•	•	•
Operating Mode Status Indication	•	•	•	•	•
VOLTAGE ADJUSTMENT					
Display Voltage Bias	•	•	•	•	•
Digital Input (Raise Lower) Voltage Bias ¹	•	•	•	•	•
Potentiometer Voltage Bias ¹	•	•	•	•	•
Analog Voltage Bias - Voltage Range ¹	0V to 5V	0V to 5V	-10V to +10V	-10V to +10V	-10V to +10V
Analog Voltage Bias - Current Range ¹	-	-	0mA to 20mA	0mA to 20mA	0mA to 20mA
Analog Voltage Bias - PWM Range ¹	-	-	0% to 100%	0% to 100%	0% to 100%
SCADA (Modbus) Voltage Bias	-	•	•	•	•

¹Requires an available input on the EMCP 4.

EMCP 4 DISPLAY

EXAMPLE SCREENS - EMCP 4.1/4.2

VOLTS / Hz	
TARGET VOLT	480 V
EXCITATION CMD	4.5 %

Figure 3: IVR Overview Screen

VOLTAGE BIAS OVERVIEW	
MANUAL	10.0%
ANALOG	2.0%

DROOP	-2.0%
TOTAL	10.0%

Figure 4: Voltage Bias Overview Screens

EXAMPLE SCREENS - EMCP 4.3/4.4

IVR OVERVIEW	
OPERATING MODE:	
VOLTS / Hz	
TARGET VOLTAGE	480 V
EXCITATION COMMAND	4.5 %
COMPENSATION	DROOP
GENSET	PAGE DOWN

Figure 5: IVR Overview Screen

VOLTAGE BIAS OVERVIEW	
ACTIVE VOLTAGE BIASING:	
MANUAL	10.0%
ANALOG INPUT	2.0%
DROOP	-2.0%
TOTAL BIAS	10.0%
GENSET	PAGE UP

Figure 6: Voltage Bias Overview Screen

INTEGRATED VOLTAGE REGULATOR



EXAMPLE SCREENS – Cat ECS 100 / Cat ECS 200



Figure 7: Cat ECS 100 / Cat ECS 200 IVR Overview

Materials and specifications are subject to change without notice.
The International System of Units (SI) is used in this publication.

© 2024 Caterpillar. All Rights Reserved. CAT, CATERPILLAR, LET'S DO THE WORK, their respective logos, "Caterpillar Corporate Yellow", the "Power Edge" and Cat "Modern Hex" trade dress as well as corporate and product identity used herein, are trademarks of Caterpillar and may not be used without permission.

www.cat.com/electricpower

Performance Number: EM7357

Change Level: 02

SALES MODEL:	C32B	COMBUSTION:	DIRECT INJECTION
BRAND:	CAT	ENGINE SPEED (RPM):	1,800
MACHINE SALES MODEL:		HERTZ:	60
ENGINE POWER (BHP):	2,218	FAN POWER (HP):	100.6
GEN POWER WITH FAN (EKW):	1,500.0	ASPIRATION:	TA
COMPRESSION RATIO:	14	AFTERCOOLER TYPE:	ATAAC
RATING LEVEL:	STANDBY	AFTERCOOLER CIRCUIT TYPE:	JW+OC, ATAAC
PUMP QUANTITY:	1	INLET MANIFOLD AIR TEMP (F):	122
FUEL TYPE:	DIESEL	JACKET WATER TEMP (F):	203.0
MANIFOLD TYPE:	DRY	TURBO CONFIGURATION:	PARALLEL
ELECTRONICS TYPE:	ADEM5	TURBO QUANTITY:	2
IGNITION TYPE:	CI	CERTIFICATION YEAR:	2024
REF EXH STACK DIAMETER (IN):	8	PISTON SPD @ RATED ENG SPD (FT/MIN):	1,913.4
MAX OPERATING ALTITUDE (FT):	984		

INDUSTRY	SubIndustry	APPLICATION
ELECTRIC POWER	STANDARD	PACKAGED GENSET

General Performance Data

GENSET POWER WITH FAN	PERCENT LOAD	ENGINE POWER	BRAKE MEAN EFF PRES (BMEP)	BRAKE SPEC FUEL CONSUMPTN (BSFC)	ISO BRAKE SPEC FUEL CONSUMPTN (BSFC)	VOL FUEL CONSUMPTN (VFC)	ISO VOL FUEL CONSUMPTN (VFC)	ELEC SPEC FUEL CONSUMPTN (ESFC)	ISO ELEC SPEC FUEL CONSUMPTN (ESFC)
EKW	%	BHP	PSI	LB/BHP-HR	LB/BHP-HR	GAL/HR	GAL/HR	LB/EKW-HR	LB/EKW-HR
1,500.0	100	2,218	498	0.331	0.326	103.4	101.9	0.489	0.482
1,350.0	90	2,005	450	0.338	0.333	95.6	94.2	0.502	0.495
1,200.0	80	1,794	403	0.344	0.339	86.9	85.7	0.514	0.506
1,125.0	75	1,689	379	0.349	0.344	83.0	81.8	0.523	0.516
1,050.0	70	1,583	356	0.344	0.339	76.7	75.6	0.518	0.511
900.0	60	1,374	309	0.353	0.348	68.5	67.5	0.540	0.532
750.0	50	1,166	262	0.362	0.357	59.5	58.7	0.563	0.555
600.0	40	961	216	0.352	0.347	47.7	47.0	0.564	0.556
450.0	30	756	170	0.361	0.356	38.4	37.9	0.606	0.597
375.0	25	651	146	0.366	0.361	33.6	33.1	0.636	0.627
300.0	20	545	123	0.367	0.361	28.2	27.8	0.666	0.657
150.0	10	327	74	0.401	0.396	18.5	18.3	0.876	0.864

GENSET POWER WITH FAN	PERCENT LOAD	ENGINE POWER	INLET MFLD PRES	INLET MFLD TEMP	EXH MFLD TEMP	EXH MFLD PRES	ENGINE OUTLET TEMP	COMPRESSOR OUTLET PRES	COMPRESSOR OUTLET TEMP
EKW	%	BHP	IN-HG	DEG F	DEG F	IN-HG	DEG F	IN-HG	DEG F
1,500.0	100	2,218	108.0	120.5	1,252.6	72.1	857.5	114	480.1
1,350.0	90	2,005	101.8	113.8	1,230.5	67.2	848.7	107	461.0
1,200.0	80	1,794	92.6	110.4	1,208.4	59.8	843.3	98	434.3
1,125.0	75	1,689	89.3	108.3	1,191.8	58.0	840.4	94	426.1
1,050.0	70	1,583	77.6	103.1	1,177.0	49.5	845.3	82	393.5
900.0	60	1,374	66.9	102.4	1,168.9	42.2	857.8	71	362.8
750.0	50	1,166	52.9	101.3	1,180.5	33.2	888.8	56	320.4
600.0	40	961	30.9	97.8	1,187.2	19.9	938.1	33	240.7
450.0	30	756	17.9	95.5	1,145.0	12.5	924.3	20	185.3
375.0	25	651	13.6	95.3	1,092.0	10.2	884.6	15	164.6
300.0	20	545	9.8	95.4	1,014.7	8.2	825.7	11	145.1
150.0	10	327	3.6	94.3	800.7	5.1	661.7	5	114.6

GENSET POWER WITH FAN	PERCENT LOAD	ENGINE POWER	WET INLET AIR VOL FLOW RATE	ENGINE OUTLET WET EXH GAS VOL FLOW RATE	WET INLET AIR MASS FLOW RATE	WET EXH GAS MASS FLOW RATE	WET EXH VOL FLOW RATE (32 DEG F AND 29.98 IN HG)	DRY EXH VOL FLOW RATE (32 DEG F AND 29.98 IN HG)
EKW	%	BHP	CFM	CFM	LB/HR	LB/HR	FT3/MIN	FT3/MIN
1,500.0	100	2,218	4,302.9	11,198.4	19,137.7	19,871.2	4,180.0	3,819.9
1,350.0	90	2,005	4,163.7	10,695.5	18,417.5	19,095.5	4,019.3	3,680.9
1,200.0	80	1,794	3,928.3	9,948.9	17,219.0	17,835.5	3,754.1	3,445.4
1,125.0	75	1,689	3,857.1	9,736.8	16,913.9	17,502.8	3,682.3	3,385.7
1,050.0	70	1,583	3,531.4	8,864.1	15,321.9	15,866.0	3,339.6	3,067.2
900.0	60	1,374	3,213.6	8,075.5	13,833.2	14,318.9	3,013.8	2,769.6
750.0	50	1,166	2,769.8	7,058.0	11,810.8	12,233.2	2,573.4	2,362.1
600.0	40	961	2,012.1	5,269.4	8,487.4	8,825.7	1,853.6	1,687.1
450.0	30	756	1,563.0	4,057.3	6,554.4	6,830.5	1,441.5	1,307.5
375.0	25	651	1,412.9	3,546.6	5,917.2	6,156.0	1,297.1	1,180.1
300.0	20	545	1,272.3	3,038.6	5,322.4	5,522.1	1,162.3	1,063.3
150.0	10	327	1,049.7	2,168.7	4,387.1	4,518.5	950.9	882.4

Heat Rejection Data

GENSET POWER WITH FAN	PERCENT LOAD	ENGINE POWER	REJECTION TO JACKET WATER	REJECTION TO ATMOSPHERE	REJECTION TO EXH	EXHAUST RECOVERY TO 350F	FROM OIL COOLER	FROM AFTERCOOLER	WORK ENERGY	LOW HEAT VALUE ENERGY	HIGH HEAT VALUE ENERGY
EKW	%	BHP	BTU/MIN	BTU/MIN	BTU/MIN	BTU/MIN	BTU/MIN	BTU/MIN	BTU/MIN	BTU/MIN	BTU/MIN
1,500.0	100	2,218	26,109	15,093	79,792	42,716	11,978	27,853	94,058	224,890	239,564

1,350.0	90	2,005	24,448	13,949	75,365	40,248	11,071	25,897	85,018	207,851	221,413
1,200.0	80	1,794	22,215	12,685	69,575	37,135	10,068	22,485	76,063	189,017	201,350
1,125.0	75	1,689	21,253	12,115	67,620	36,187	9,615	21,714	71,610	180,522	192,301
1,050.0	70	1,583	19,917	11,197	61,933	33,164	8,887	17,936	67,149	166,851	177,738
900.0	60	1,374	18,297	9,993	56,556	30,696	7,931	14,499	58,280	148,903	158,619
750.0	50	1,166	16,917	8,689	50,143	27,906	6,896	10,405	49,447	129,467	137,915
600.0	40	961	16,189	6,962	38,850	22,144	5,525	4,998	40,775	103,739	110,508
450.0	30	756	15,068	5,611	29,863	16,749	4,453	2,333	32,045	83,610	89,066
375.0	25	651	14,076	4,906	25,761	13,993	3,894	1,640	27,623	73,104	77,874
300.0	20	545	12,840	4,113	21,314	11,092	3,264	1,058	23,131	61,287	65,286
150.0	10	327	9,991	2,703	13,456	5,831	2,146	345	13,882	40,282	42,910

Sound Data

EXHAUST:SOUND POWER(1/3 Octave Frequencies)

GENSET POWER WITH FAN	PERCENT LOAD	ENGINE SPEED	ENGINE POWER	OVERALL SOUND	100 HZ	125 HZ	160 HZ	200 HZ	250 HZ	315 HZ	400 HZ	500 HZ	630 HZ	800 HZ
EKW	%	RPM	BHP	dB(A)	dB(A)	dB(A)	dB(A)	dB(A)	dB(A)	dB(A)	dB(A)	dB(A)	dB(A)	dB(A)
1,500.0	100	1,800	2,218	122.8	106.9	104.3	106.4	113.8	111.2	110.7	111.2	110.5	108.3	109.1
1,350.0	90	1,800	2,005	122.1	106.2	103.6	105.2	112.9	109.8	109.4	110.4	110.5	108.0	108.4
1,200.0	80	1,800	1,794	121.3	105.8	103.5	104.8	112.3	108.1	109.1	109.2	109.8	107.5	107.5
1,125.0	75	1,800	1,689	120.8	105.3	102.8	104.9	112.5	107.0	108.3	108.6	109.4	106.8	106.8
1,050.0	70	1,800	1,583	120.8	105.4	104.2	105.6	112.8	108.7	109.9	108.6	109.2	106.2	106.7
900.0	60	1,800	1,374	119.8	105.8	104.6	106.0	112.8	107.6	109.0	107.0	108.0	105.0	105.5
750.0	50	1,800	1,166	119.4	105.0	104.8	107.7	112.5	107.4	109.7	107.3	107.4	104.1	104.2
600.0	40	1,800	961	118.8	107.0	102.0	107.2	111.4	107.8	109.9	105.8	105.1	102.5	102.9
450.0	30	1,800	756	117.1	105.2	98.8	104.8	109.1	106.9	108.1	103.8	103.0	101.8	100.9
375.0	25	1,800	651	116.3	105.6	97.4	104.1	108.6	106.6	107.0	104.0	102.8	100.4	99.2
300.0	20	1,800	545	116.2	105.4	96.5	103.4	109.2	106.5	105.6	103.5	102.4	99.9	98.8
150.0	10	1,800	327	115.0	105.3	97.0	103.1	110.0	102.3	103.2	97.8	98.8	97.3	97.6

EXHAUST:SOUND POWER(1/3 Octave Frequencies)

GENSET POWER WITH FAN	PERCENT LOAD	ENGINE SPEED	ENGINE POWER	1000 HZ	1250 HZ	1600 HZ	2000 HZ	2500 HZ	3150 HZ	4000 HZ	5000 HZ	6300 HZ	8000 HZ	10000 HZ
EKW	%	RPM	BHP	dB(A)	dB(A)	dB(A)	dB(A)	dB(A)	dB(A)	dB(A)	dB(A)	dB(A)	dB(A)	dB(A)
1,500.0	100	1,800	2,218	111.2	109.8	109.5	109.8	110.1	109.3	111.4	109.9	107.1	104.2	95.5
1,350.0	90	1,800	2,005	110.6	109.3	108.9	109.9	109.7	108.8	110.4	108.6	105.4	101.5	94.6
1,200.0	80	1,800	1,794	109.7	108.5	108.2	110.1	109.5	108.2	108.8	107.2	103.4	98.8	95.1
1,125.0	75	1,800	1,689	109.0	108.6	107.3	109.5	109.1	108.0	108.3	106.9	102.1	97.0	93.8
1,050.0	70	1,800	1,583	108.8	109.1	106.5	107.9	108.2	107.3	107.9	106.6	101.2	95.5	92.2

900.0	60	1,800	1,374	107.5	106.1	105.4	105.1	106.1	106.1	106.6	105.6	100.0	94.3	92.1
750.0	50	1,800	1,166	106.3	105.4	104.3	104.3	104.7	105.0	105.7	105.1	99.4	93.1	91.9
600.0	40	1,800	961	104.6	104.3	103.4	104.4	103.5	104.7	105.3	104.7	98.7	97.1	88.4
450.0	30	1,800	756	102.8	102.9	102.9	103.3	102.8	103.8	103.5	102.4	97.6	89.4	83.8
375.0	25	1,800	651	100.8	101.5	101.2	101.9	101.3	102.5	101.6	100.2	97.4	85.5	80.3
300.0	20	1,800	545	100.7	101.7	101.5	103.4	102.2	102.8	101.4	100.6	94.8	83.7	78.8
150.0	10	1,800	327	99.9	99.6	101.5	104.5	101.1	99.5	98.4	94.2	85.9	79.7	72.2

MECHANICAL:SOUND POWER(1/3 Octave Frequencies)

GENSET POWER WITH FAN	PERCENT LOAD	ENGINE POWER	OVERALL SOUND	100 HZ	125 HZ	160 HZ	200 HZ	250 HZ	315 HZ	400 HZ	500 HZ	630 HZ	800 HZ
EKW	%	BHP	dB(A)	dB(A)	dB(A)	dB(A)	dB(A)	dB(A)	dB(A)	dB(A)	dB(A)	dB(A)	dB(A)
1,500.0	100	2,218	124.2	96.7	110.0	99.5	104.9	109.1	106.0	109.8	108.8	110.6	112.5
1,350.0	90	2,005	123.8	96.0	109.4	98.9	103.7	108.6	105.9	109.7	108.3	110.5	112.1
1,200.0	80	1,794	123.8	95.1	109.2	98.6	102.0	107.7	105.5	109.3	107.8	110.6	112.2
1,125.0	75	1,689	128.1	94.9	109.3	98.4	101.6	107.0	105.5	109.2	107.6	110.6	112.0
1,050.0	70	1,583	127.0	94.5	109.5	98.7	101.6	107.0	105.4	109.1	107.6	110.8	112.0
900.0	60	1,374	123.2	93.7	109.1	98.5	101.1	108.4	105.4	108.9	107.7	111.1	112.3
750.0	50	1,166	122.8	92.7	109.5	98.5	101.0	107.6	105.4	109.4	108.3	110.3	112.3
600.0	40	961	122.4	94.1	109.5	99.4	102.5	107.9	105.2	109.3	108.7	110.2	112.4
450.0	30	756	121.9	92.8	109.6	98.3	102.8	107.7	105.6	109.1	107.8	110.4	111.9
375.0	25	651	121.9	92.1	109.4	97.8	102.5	107.5	105.3	109.0	108.0	110.9	112.3
300.0	20	545	121.7	93.0	109.5	97.7	102.6	107.3	105.1	109.0	108.1	111.3	112.7
150.0	10	327	121.1	91.7	109.4	96.8	101.1	107.1	104.6	108.7	107.7	111.1	112.8

MECHANICAL:SOUND POWER(1/3 Octave Frequencies)

GENSET POWER WITH FAN	PERCENT LOAD	ENGINE POWER	1000 HZ	1250 HZ	1600 HZ	2000 HZ	2500 HZ	3150 HZ	4000 HZ	5000 HZ	6300 HZ	8000 HZ	10000 HZ
EKW	%	BHP	dB(A)	dB(A)	dB(A)	dB(A)	dB(A)	dB(A)	dB(A)	dB(A)	dB(A)	dB(A)	dB(A)
1,500.0	100	2,218	113.1	112.5	112.1	111.3	110.4	108.6	106.5	105.4	109.0	116.5	116.0
1,350.0	90	2,005	112.4	112.3	111.7	111.4	110.0	108.2	105.8	104.8	108.2	115.7	116.2
1,200.0	80	1,794	112.0	115.4	111.3	110.8	109.5	107.9	105.4	104.3	107.8	115.4	116.2
1,125.0	75	1,689	113.0	126.4	112.4	110.9	109.7	107.8	105.2	103.9	107.2	115.0	115.1
1,050.0	70	1,583	113.9	124.9	111.8	111.0	109.7	107.9	105.3	104.0	106.9	115.0	114.4
900.0	60	1,374	113.9	113.3	111.6	111.4	109.2	108.0	104.5	103.1	106.0	114.9	112.5
750.0	50	1,166	112.9	112.4	111.2	110.7	108.9	107.7	104.1	102.3	104.9	114.7	111.1
600.0	40	961	113.3	111.7	112.2	111.9	109.4	107.9	104.5	102.5	105.2	110.5	107.4
450.0	30	756	113.3	112.0	111.7	111.4	108.9	107.4	104.4	102.6	101.6	107.2	105.1

375.0	25	651	113.1	112.3	111.7	111.2	109.0	107.1	104.3	101.2	100.2	105.8	103.9
300.0	20	545	112.8	111.6	111.3	110.9	108.5	107.0	104.8	99.9	99.2	104.3	102.0
150.0	10	327	112.7	111.2	110.8	109.6	107.6	106.7	102.7	99.0	97.9	99.7	93.8

Emissions Data

DIESEL

RATED SPEED NOMINAL DATA: 1800 RPM

GENSET POWER WITH FAN		EKW	1,500.0	1,125.0	750.0	375.0	150.0
ENGINE POWER		BHP	2,218	1,689	1,166	651	327
PERCENT LOAD		%	100	75	50	25	10
TOTAL NOX (AS NO2)		G/HR	12,850	6,702	3,754	3,139	2,051
TOTAL CO		G/HR	415	925	1,881	1,030	900
TOTAL HC		G/HR	220	166	95	61	130
TOTAL CO2		KG/HR	1,050	846	597	336	184
PART MATTER		G/HR	33.2	57.0	100.3	53.5	22.9
TOTAL NOX (AS NO2)	(CORR 5% O2)	MG/NM3	2,844.1	1,842.7	1,456.7	2,221.0	2,525.5
TOTAL CO	(CORR 5% O2)	MG/NM3	82.0	258.5	738.2	643.3	1,273.9
TOTAL HC	(CORR 5% O2)	MG/NM3	42.4	39.3	32.0	39.0	172.9
PART MATTER	(CORR 5% O2)	MG/NM3	5.7	13.4	33.1	31.6	23.4
TOTAL NOX (AS NO2)	(CORR 15% O2)	MG/NM3	1,055.4	683.8	540.5	824.1	937.1
TOTAL CO	(CORR 15% O2)	MG/NM3	30.4	95.9	273.9	238.7	472.7
TOTAL HC	(CORR 15% O2)	MG/NM3	15.7	14.6	11.9	14.5	64.2
PART MATTER	(CORR 15% O2)	MG/NM3	2.1	5.0	12.3	11.7	8.7
TOTAL NOX (AS NO2)	(CORR 5% O2)	PPM	1,385	898	710	1,082	1,230
TOTAL CO	(CORR 5% O2)	PPM	66	207	591	515	1,019
TOTAL HC	(CORR 5% O2)	PPM	79	73	60	73	323
TOTAL NOX (AS NO2)	(CORR 15% O2)	PPM	514	333	263	401	456
TOTAL CO	(CORR 15% O2)	PPM	24	77	219	191	378
TOTAL HC	(CORR 15% O2)	PPM	29	27	22	27	120
TOTAL NOX (AS NO2)		G/HP-HR	5.87	4.00	3.24	4.84	6.28
TOTAL CO		G/HP-HR	0.19	0.55	1.62	1.59	2.75
TOTAL HC		G/HP-HR	0.10	0.10	0.08	0.09	0.40
PART MATTER		G/HP-HR	0.02	0.03	0.09	0.08	0.07
TOTAL NOX (AS NO2)		G/KW-HR	7.88	5.37	4.34	6.48	8.42
TOTAL CO		G/KW-HR	0.25	0.74	2.18	2.13	3.69
TOTAL HC		G/KW-HR	0.13	0.13	0.11	0.13	0.53
PART MATTER		G/KW-HR	0.02	0.05	0.12	0.11	0.09

TOTAL NOX (AS NO2)		LB/HR	28.33	14.78	8.28	6.92	4.52
TOTAL CO		LB/HR	0.91	2.04	4.15	2.27	1.98
TOTAL HC		LB/HR	0.48	0.36	0.21	0.13	0.29
TOTAL CO2		LB/HR	2,314	1,865	1,317	741	406
PART MATTER		LB/HR	0.07	0.13	0.22	0.12	0.05
OXYGEN IN EXH		%	9.8	10.8	10.6	9.9	12.4
DRY SMOKE OPACITY		%	0.3	1.0	2.6	2.7	1.2
BOSCH SMOKE NUMBER			0.62	0.76	1.06	1.08	0.80

RATED SPEED POTENTIAL SITE VARIATION: 1800 RPM

GENSET POWER WITH FAN		EKW	1,500.0	1,125.0	750.0	375.0	150.0
ENGINE POWER		BHP	2,218	1,689	1,166	651	327
PERCENT LOAD		%	100	75	50	25	10
TOTAL NOX (AS NO2)		G/HR	15,549	8,109	4,542	3,798	2,482
TOTAL CO		G/HR	776	1,729	3,517	1,926	1,682
TOTAL HC		G/HR	415	313	180	115	246
PART MATTER		G/HR	64.7	111.1	195.6	104.2	44.6
TOTAL NOX (AS NO2)	(CORR 5% O2)	MG/NM3	3,441.4	2,229.7	1,762.6	2,687.4	3,055.9
TOTAL CO	(CORR 5% O2)	MG/NM3	153.3	483.3	1,380.4	1,202.9	2,382.1
TOTAL HC	(CORR 5% O2)	MG/NM3	80.1	74.4	60.4	73.8	326.8
PART MATTER	(CORR 5% O2)	MG/NM3	11.2	26.1	64.6	61.5	45.6
TOTAL NOX (AS NO2)	(CORR 15% O2)	MG/NM3	1,277.0	827.4	654.1	997.2	1,133.9
TOTAL CO	(CORR 15% O2)	MG/NM3	56.9	179.4	512.2	446.4	883.9
TOTAL HC	(CORR 15% O2)	MG/NM3	29.7	27.6	22.4	27.4	121.3
PART MATTER	(CORR 15% O2)	MG/NM3	4.2	9.7	24.0	22.8	16.9
TOTAL NOX (AS NO2)	(CORR 5% O2)	PPM	1,676	1,086	859	1,309	1,489
TOTAL CO	(CORR 5% O2)	PPM	123	387	1,104	962	1,906
TOTAL HC	(CORR 5% O2)	PPM	150	139	113	138	610
TOTAL NOX (AS NO2)	(CORR 15% O2)	PPM	622	403	319	486	552
TOTAL CO	(CORR 15% O2)	PPM	46	143	410	357	707
TOTAL HC	(CORR 15% O2)	PPM	55	52	42	51	226
TOTAL NOX (AS NO2)		G/HP-HR	7.11	4.84	3.92	5.85	7.60
TOTAL CO		G/HP-HR	0.35	1.03	3.03	2.97	5.15
TOTAL HC		G/HP-HR	0.19	0.19	0.16	0.18	0.75
PART MATTER		G/HP-HR	0.03	0.07	0.17	0.16	0.14

TOTAL NOX (AS NO2)		G/KW-HR	9.53	6.49	5.25	7.85	10.19
TOTAL CO		G/KW-HR	0.48	1.38	4.07	3.98	6.90
TOTAL HC		G/KW-HR	0.25	0.25	0.21	0.24	1.01
PART MATTER		G/KW-HR	0.04	0.09	0.23	0.22	0.18
TOTAL NOX (AS NO2)		LB/HR	34.28	17.88	10.01	8.37	5.47
TOTAL CO		LB/HR	1.71	3.81	7.75	4.25	3.71
TOTAL HC		LB/HR	0.92	0.69	0.40	0.25	0.54
PART MATTER		LB/HR	0.14	0.24	0.43	0.23	0.10

Regulatory Information

EPA EMERGENCY STATIONARY		2011 - ----		
GASEOUS EMISSIONS DATA MEASUREMENTS PROVIDED TO THE EPA ARE CONSISTENT WITH THOSE DESCRIBED IN EPA 40 CFR PART 60 SUBPART IIII AND ISO 8178 FOR MEASURING HC, CO, PM, AND NOX. THE "MAX LIMITS" SHOWN BELOW ARE WEIGHTED CYCLE AVERAGES AND ARE IN COMPLIANCE WITH THE EMERGENCY STATIONARY REGULATIONS.				
Locality	Agency	Regulation	Tier/Stage	Max Limits - G/BKW - HR
U.S. (INCL CALIF)	EPA	STATIONARY	EMERGENCY STATIONARY	CO: 3.5 NOx + HC: 6.4 PM: 0.20

Altitude Derate Data

Note(s)
THE FOLLOWING ALTITUDE DERATE TABLE INCLUDES SOFTWARE DERATES THAT PROTECT THE ENGINE AT HIGH AMBIENT TEMPERATURES AND ALTITUDES. ACTUAL OBSERVED POWER CAN CHANGE DUE TO AMBIENT CONDITIONS AND FUEL USED. PLEASE REVIEW THE SUPPLEMENTARY FILE LINKED TO THIS PERFORMANCE FILE FOR ADDITIONAL INFORMATION.

STANDARD

ALTITUDE CORRECTED POWER CAPABILITY (BHP)

AMBIENT OPERATING TEMP (F)	30	40	50	60	70	80	90	100	110	120	130	140	NORMAL
ALTITUDE (FT)													
0	2,218	2,218	2,218	2,218	2,218	2,218	2,218	2,218	2,218	2,218	2,010	959	2,218
1,000	2,218	2,218	2,218	2,218	2,218	2,218	2,218	2,218	2,218	2,203	1,952	1,022	2,218
2,000	2,218	2,218	2,218	2,218	2,218	2,218	2,218	2,218	2,189	2,089	1,875	1,395	2,218
3,000	2,218	2,218	2,218	2,218	2,218	2,210	2,183	2,154	2,107	1,966	1,791	1,406	2,218
4,000	2,218	2,218	2,208	2,182	2,152	2,126	2,090	2,054	2,001	1,840	1,713	1,381	2,174
5,000	2,194	2,163	2,131	2,095	2,057	2,023	1,981	1,942	1,872	1,738	1,646	1,340	2,098

6,000	2,116	2,074	2,031	1,987	1,942	1,908	1,869	1,833	1,756	1,669	1,606	1,286	2,007
7,000	2,011	1,964	1,917	1,875	1,833	1,804	1,769	1,739	1,699	1,636	1,569	1,229	1,910
8,000	1,898	1,856	1,814	1,776	1,743	1,721	1,693	1,668	1,646	1,605	1,500	1,196	1,822
9,000	1,794	1,758	1,726	1,697	1,668	1,658	1,644	1,630	1,613	1,562	1,420	1,170	1,745
10,000	1,723	1,693	1,668	1,651	1,634	1,624	1,608	1,589	1,563	1,493	1,340	1,174	1,691
11,000	1,669	1,654	1,638	1,620	1,597	1,580	1,556	1,531	1,503	1,414	1,272	1,175	1,659
12,000	1,636	1,621	1,597	1,571	1,544	1,526	1,499	1,470	1,435	1,346	1,235	1,174	1,633
13,000	1,585	1,560	1,534	1,505	1,475	1,454	1,427	1,399	1,367	1,292	1,217	1,172	1,587
14,000	1,530	1,498	1,465	1,435	1,406	1,388	1,364	1,342	1,309	1,263	1,227	1,170	1,543
15,000	1,469	1,436	1,405	1,380	1,354	1,338	1,317	1,303	1,282	1,244	1,235	1,165	1,494

Cross Reference

Test Spec	Setting	Engine Arrangement	Engineering Model	Engineering Model Version	Start Effective Serial Number	End Effective Serial Number
6351415	GG3079	6293602	PG521	-	LZR00001	

Supplementary Data

Type	Classification	Performance Number
ALTITUDE DATA	WITH NATURAL DERATE	EM7407

Performance Parameter Reference

<p>Parameters Reference: DM9600 - 15</p> <p>PERFORMANCE DEFINITIONS</p> <p>PERFORMANCE DEFINITIONS DM9600</p> <p>APPLICATION: Engine performance tolerance values below are representative of a typical production engine tested in a calibrated dynamometer test cell at SAE J1995 standard reference conditions. Caterpillar maintains ISO9001:2000 certified quality management systems for engine test Facilities to assure accurate calibration of test equipment. Engine test data is corrected in accordance with SAE J1995. Additional reference material SAE J1228, J1349, ISO 8665, 3046-1:2002E, 3046-3:1989, 1585, 2534, 2288, and 9249 may apply in part or are similar to SAE J1995. Special engine rating request (SERR) test data shall be noted.</p> <p>PERFORMANCE PARAMETER TOLERANCE FACTORS: Power +/- 3% Torque +/- 3% Exhaust stack temperature +/- 8% Inlet airflow +/- 5% Intake manifold pressure-gage +/- 10% Exhaust flow +/- 6% Specific fuel consumption +/- 3% Specific fuel consumption (C7-C18) +/- 4% Fuel rate +/- 5% Specific DEF consumption +/- 3% DEF rate +/- 5% Heat rejection +/- 5% Heat rejection exhaust only +/- 10% Heat rejection CEM only +/- 10% Heat Rejection values based on using treated water. Torque is included for truck and industrial applications, do not use for Gen Set or steady state applications. On C7 - C18 engines, at speeds of 1100 RPM and under these values are provided for reference only, and may not meet the tolerance listed. On 3500 and C175 engines, at speeds below Peak Torque these values are provided for reference only, and may not meet the tolerance listed. These values do not apply to C280/3600. For these models, see the tolerances listed below.</p> <p>C280/3600 HEAT REJECTION TOLERANCE FACTORS: Heat rejection +/- 10% Heat rejection to Atmosphere +/- 50% Heat rejection to Lube Oil +/- 20% Heat rejection to Aftercooler +/- 5%</p> <p>TEST CELL TRANSDUCER TOLERANCE FACTORS: Torque +/- 0.5% Speed +/- 0.2% Fuel flow +/- 1.0% Temperature +/- 2.0 C degrees Intake manifold pressure +/- 0.1 kPa OBSERVED ENGINE PERFORMANCE IS CORRECTED TO SAE J1995 REFERENCE AIR AND FUEL CONDITIONS.</p> <p>REFERENCE ATMOSPHERIC INLET AIR FOR 3500 ENGINES AND SMALLER SAE J1228 AUG2002 for marine engines, and J1995 JAN2014 for other engines, reference atmospheric pressure is 100 KPA (29.61 in hg), and standard temperature is 25deg C (77 deg F) at 30% relative humidity at the stated aftercooler water temp, or inlet manifold temp. FOR 3600 ENGINES Engine rating obtained and presented in accordance with ISO 3046/1 and SAE J1995 JANJAN2014 reference atmospheric pressure is 100 KPA (29.61 in hg), and standard temperature is 25deg C (77 deg F) at 30% relative humidity and 150M altitude at the stated aftercooler water temperature.</p> <p>MEASUREMENT LOCATION FOR INLET AIR TEMPERATURE Location for air temperature measurement air cleaner inlet at stabilized operating conditions.</p> <p>REFERENCE EXHAUST STACK DIAMETER The Reference Exhaust Stack Diameter published with this dataset is only used for the calculation of Smoke Opacity values displayed in this dataset. This value does not necessarily represent the actual stack diameter of the engine due to the variety of exhaust stack adapter options available. Consult the price list, engine order or general dimension drawings for the actual stack diameter size ordered or options available.</p> <p>REFERENCE FUEL DIESEL Reference fuel is #2 distillate diesel with a 35API gravity; A lower heating value is 42,780 KJ/KG (18,390 BTU/LB) when used at 15 deg C (59 deg F), where the density is</p>

850 G/Liter (7.0936 Lbs/Gal).

GAS Reference natural gas fuel has a lower heating value of 33.74 KJ/L (905 BTU/CU Ft). Low BTU ratings are based on 18.64 KJ/L (500 BTU/CU FT) lower heating value gas. Propane ratings are based on 87.56 KJ/L (2350 BTU/CU Ft) lower heating value gas.

ENGINE POWER (NET) IS THE CORRECTED FLYWHEEL POWER (GROSS) LESS EXTERNAL AUXILIARY LOAD Engine corrected gross output includes the power required to drive standard equipment; lube oil, scavenge lube oil, fuel transfer, common rail fuel, separate circuit aftercooler and jacket water pumps. Engine net power available for the external (flywheel) load is calculated by subtracting the sum of auxiliary load from the corrected gross flywheel out put power. Typical auxiliary loads are radiator cooling fans, hydraulic pumps, air compressors and battery charging alternators. For Tier 4 ratings additional Parasitic losses would also include Intake, and Exhaust Restrictions.

ALTITUDE CAPABILITY Altitude capability is the maximum altitude above sea level at standard temperature and standard pressure at which the engine could develop full rated output power on the current performance data set.

Standard temperature values versus altitude could be seen on TM2001.

When viewing the altitude capability chart the ambient temperature is the inlet air temp at the compressor inlet.

Engines with ADEM MEUI and HEUI fuel systems operating at conditions above the defined altitude capability derate for atmospheric pressure and temperature conditions outside the values defined, see TM2001.

Mechanical governor controlled unit injector engines require a setting change for operation at conditions above the altitude defined on the engine performance sheet. See your Caterpillar technical representative for non standard ratings.

REGULATIONS AND PRODUCT COMPLIANCE TMI Emissions information is presented at 'nominal' and 'Potential Site Variation' values for standard ratings. No tolerances are applied to the emissions data. These values are subject to change at any time. The controlling federal and local emission requirements need to be verified by your Caterpillar technical representative. Customer's may have special emission site requirements that need to be verified by the Caterpillar Product Group engineer.

EMISSION CYCLE LIMITS: Cycle emissions Max Limits apply to cycle-weighted averages only. Emissions at individual load points may exceed the cycle-weighted limit.

WET & DRY EXHAUST/EMISSIONS DESCRIPTION: Wet - Total exhaust flow or concentration of total exhaust flow Dry - Total exhaust flow minus water vapor or concentration of exhaust flow with water vapor excluded

EMISSIONS DEFINITIONS: Emissions : DM1176

EMISSION CYCLE DEFINITIONS

1. For constant-speed marine engines for ship main propulsion, including,diesel-electric drive, test cycle E2 shall be applied, for controllable-pitch propeller sets test cycle E2 shall be applied.
2. For propeller-law-operated main and propeller-law-operated auxiliary engines the test cycle E3 shall be applied.
3. For constant-speed auxiliary engines test cycle D2 shall be applied.
4. For variable-speed, variable-load auxiliary engines, not included above, test cycle C1 shall be applied.

HEAT REJECTION DEFINITIONS: Diesel Circuit Type and HHV Balance : DM9500

HIGH DISPLACEMENT (HD) DEFINITIONS: 3500: EM1500

RATING DEFINITIONS: Agriculture : TM6008

Fire Pump : TM6009

Generator Set : TM6035

Generator (Gas) : TM6041

Industrial Diesel : TM6010

Industrial (Gas) : TM6040

Irrigation : TM5749

Locomotive : TM6037

Marine Auxiliary : TM6036

Marine Prop (Except 3600) : TM5747

Marine Prop (3600 only) : TM5748

MSHA : TM6042

Oil Field (Petroleum) : TM6011

Off-Highway Truck : TM6039

On-Highway Truck : TM6038

SOUND DEFINITIONS: Sound Power : DM8702

Sound Pressure : TM7080

Date Released : 03/12/24

[Spec Info](#) [Mechanical Data](#) [Cooling Data](#) [Motor Starting Curve](#) [Open Circuit Curve](#)
[Zero Power Factor Curve](#) [Reactive Capability Chart](#) [General Information](#)

Selected Model

Engine: C32 **Generator Frame:** 1447 **Genset Rating (kW):** 1500.0 **Line Voltage:** 480
Fuel: Diesel **Generator Arrangement:** 6301134 **Genset Rating (kVA):** 1875.0 **Phase Voltage:** 277
Frequency: 60 **Excitation Type:** Permanent Magnet **Pwr. Factor:** 0.8 **Rated Current:** 2255.3
Duty: STANDBY **Connection:** SERIES STAR **Application:** EPG **Status:** Current
Version: 20259 /20253 /20259 /687196

Spec Information

Generator Specification		Generator Efficiency			
Frame: 1447	Type: SR5	No. of Bearings: 2	Per Unit Load	kW	Efficiency %
Winding Type: RANDOM WOUND	Flywheel: 18		0.25	375	93.5
Connection: SERIESSTAR	Housing: 0		0.5	750	95.4
Phases: 3	No. of Leads: 6		0.75	1125	95.6
Poles: 4	Wires per Lead: 4		1	1500	95.2
Sync Speed: 1800	Generator Pitch: 0.67				

Reactances	Per Unit	Ohms
SUBTRANSIENT - DIRECT AXIS X" _d	0.1416	0.0174
SUBTRANSIENT - QUADRATURE AXIS X" _q	0.1603	0.0197
TRANSIENT - SATURATED X' _d	0.1766	0.0217
SYNCHRONOUS - DIRECT AXIS X _d	3.9355	0.4836
SYNCHRONOUS - QUADRATURE AXIS X _q	2.3633	0.2904
NEGATIVE SEQUENCE X ₂	0.1514	0.0186
ZERO SEQUENCE X ₀	0.0342	0.0042

Time Constants	Seconds
OPEN CIRCUIT TRANSIENT - DIRECT AXIS T' _{d0}	3.9100
SHORT CIRCUIT TRANSIENT - DIRECT AXIS T' _d	0.1800
OPEN CIRCUIT SUBTRANSIENT - DIRECT AXIS T" _{d0}	0.0320
SHORT CIRCUIT SUBTRANSIENT - DIRECT AXIS T" _d	0.0180
OPEN CIRCUIT SUBTRANSIENT - QUADRATURE AXIS T" _{q0}	0.2650
SHORT CIRCUIT SUBTRANSIENT - QUADRATURE AXIS T" _q	0.0180
EXCITER TIME CONSTANT T _e	0.0600
ARMATURE SHORT CIRCUIT T _a	0.0270

Short Circuit Ratio: 0.34	Stator Resistance = 0.0025Ohms	Field Resistance = 0.506 Ohms
---------------------------	--------------------------------	-------------------------------

Voltage Regulation		Generator Excitation		
Voltage level adjustment: +/-	5.0%	No Load	Full Load, (rated) pf	
Voltage regulation, steady state: +/-	0.5%		Series	Parallel
Voltage regulation with 3% speed change: +/-	0.5%	Excitation voltage:	10.3 Volts	57.3 Volts
Waveform deviation line - line, no load: less than	2.0%	Excitation current	0.8 Amps	3.7 Amps
Telephone influence factor: less than	100			

[Top...](#)

Selected Model

Engine: C32 **Generator Frame:** 1447 **Genset Rating (kW):** 1500.0 **Line Voltage:** 480
Fuel: Diesel **Generator Arrangement:** 6301134 **Genset Rating (kVA):** 1875.0 **Phase Voltage:** 277
Frequency: 60 **Excitation Type:** Permanent Magnet **Pwr. Factor:** 0.8 **Rated Current:** 2255.3
Duty: STANDBY **Connection:** SERIES STAR **Application:** EPG **Status:** Current
Version: 20259 /20253 /20259 /687196

Generator Mechanical Information

Center of Gravity		
Dimension X	-661 mm	-26.0 IN.
Dimension Y	0 mm	0.0 IN.
Dimension Z	0 mm	0.0 IN.

- "X" is measured from driven end of generator and parallel to rotor. Towards engine fan is positive. See General Information for details
- "Y" is measured vertically from rotor center line. Up is positive.
- "Z" is measured to left and right of rotor center line. To the right is positive.

Generator WT = 3000 kg * Rotor WT = 1120 kg * Stator WT = 1880 kg
6,614 LB 2,469 LB 4,145 LB

Rotor Balance = 0.0508 mm deflection PTP
Overspeed Capacity = 125% of synchronous speed

Generator Torsional Data

J1 = Coupling and Fan **J2 = Rotor** **J3 = Exciter End**
TOTAL J = J1 + J2 + J3

K1 = Shaft Stiffness between J1 + J2 (Diameter 1) **K2 = Shaft Stiffness between J2 + J3 (Diameter 2)**

J1	K1	Min Shaft Dia 1	J2	K2	Min Shaft Dia 2	J3
21.9 LB IN. s ²	74.3 MLB IN./rad	6.7 IN.	184.4 LB IN. s ²	119.5 MLB IN./rad	5.5 IN.	8.4 LB IN. s ²
2.47 N m s ²	8.4 MN m/rad	170 mm	20.84 N m s ²	13.5 MN m/rad	140 mm	0.95 N m s ²
Total J			214.7 LB IN. s ²			
			24.26 N m s ²			

[Top...](#)

Selected Model

Engine: C32 **Generator Frame:** 1447 **Genset Rating (kW):** 1500.0 **Line Voltage:** 480
Fuel: Diesel **Generator Arrangement:** 6301134 **Genset Rating (kVA):** 1875.0 **Phase Voltage:** 277
Frequency: 60 **Excitation Type:** Permanent Magnet **Pwr. Factor:** 0.8 **Rated Current:** 2255.3
Duty: STANDBY **Connection:** SERIES STAR **Application:** EPG **Status:** Current
Version: 20259 /20253 /20259 /687196

Generator Cooling Requirements -
Temperature - Insulation Data

Cooling Requirements:	Temperature Data: (Ambient 40 °C)	
Heat Dissipated: 75.6 kW	Stator Rise:	125 °C
Air Flow: 132 m ³ /min	Rotor Rise:	125 °C
Insulation Class: H		
Insulation Reg. as shipped: 100MΩ minimum at 40 °C		

Thermal Limits of Generator	
Frequency:	60 Hz
Line to Line Voltage:	480 Volts
B BR 80/40	1500 kVA
F BR -105/40	1706 kVA
H BR - 125/40	1875 kVA
F PR - 130/40	1875 kVA
H PR - 150/40	1992 kVA
H PR27 - 163/27	2071.7 kVA

[Top..](#)

Selected Model

Engine: C32	Generator Frame: 1447	Genset Rating (kW): 1500.0	Line Voltage: 480
Fuel: Diesel	Generator Arrangement: 6301134	Genset Rating (kVA): 1875.0	Phase Voltage: 277
Frequency: 60	Excitation Type: Permanent Magnet	Pwr. Factor: 0.8	Rated Current: 2255.3
Duty: STANDBY	Connection: SERIES STAR	Application: EPG	Status: Current
Version: 20259 /20253 /20259 /687196			

Starting Capability & Current Decrement
Motor Starting Capability (0.4 pf)

SKVA Percent Volt Dip	
260	2.5
534	5.0
823	7.5
1,128	10.0
1,450	12.5
1,791	15.0
2,153	17.5
2,538	20.0
2,947	22.5
3,384	25.0
3,850	27.5
4,350	30.0
4,888	32.5
5,466	35.0
6,091	37.5
6,767	40.0

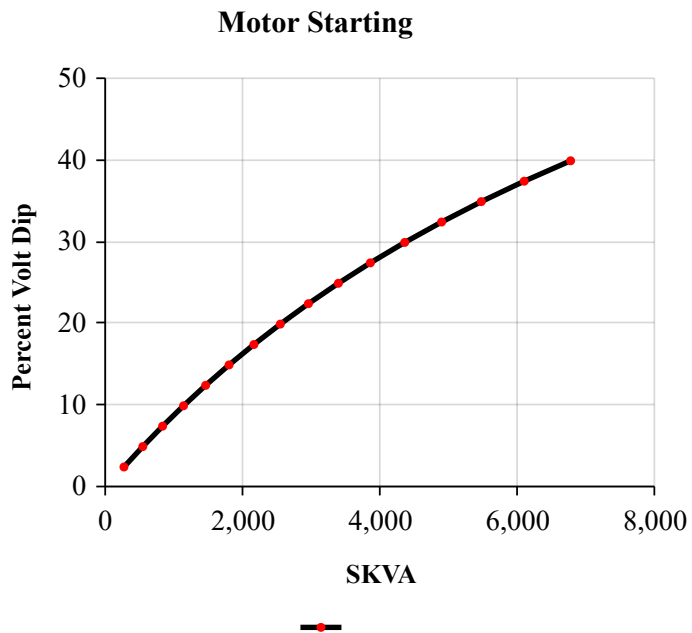

Current Decrement Data

E Time Cycle	AMP
0.0	15,887
1.0	12,954
2.0	11,229
3.0	10,048
4.0	9,125
5.0	8,346
7.5	6,758
10.0	5,518
12.5	5,375
15.0	5,994
20.0	6,997
25.0	7,566
30.0	7,800
35.0	7,579
40.0	7,272
45.0	7,023

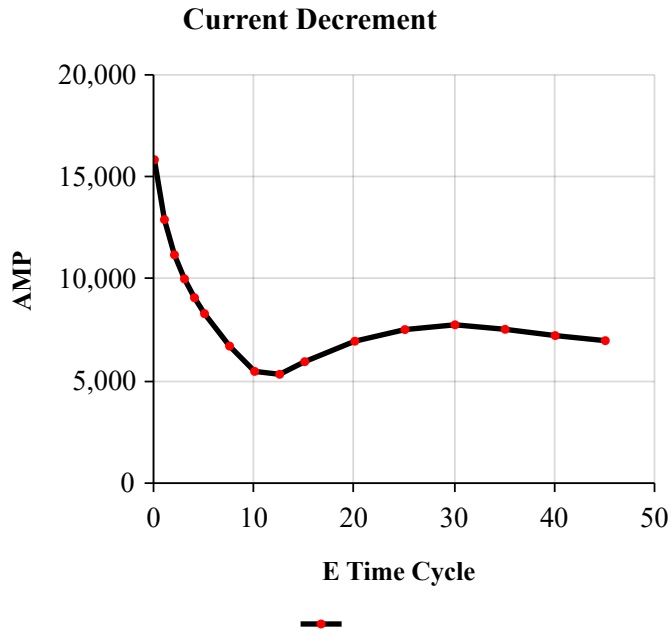

Instantaneous 3 Phase Fault Current: 15887 Amps Instantaneous Line - Line Fault Current: 13300 Amps
Instantaneous Line - Neutral Fault Current: 20629 Amps

[Top..](#)

Selected Model

Engine: C32 **Generator Frame:** 1447 **Genset Rating (kW):** 1500.0 **Line Voltage:** 480
Fuel: Diesel **Generator Arrangement:** 6301134 **Genset Rating (kVA):** 1875.0 **Phase Voltage:** 277
Frequency: 60 **Excitation Type:** Permanent Magnet **Pwr. Factor:** 0.8 **Rated Current:** 2255.3
Duty: STANDBY **Connection:** SERIES STAR **Application:** EPG **Status:** Current
Version: 20259 /20253 /20259 /687196

Generator Output Characteristic Curves
Open Circuit Curve

Open Circuit

Field Current	Line - Line Volt
0.0	0
15.6	288
18.4	336
21.6	384
25.6	432
31.7	480
42.8	528
65.8	576
117.8	624
239.7	672

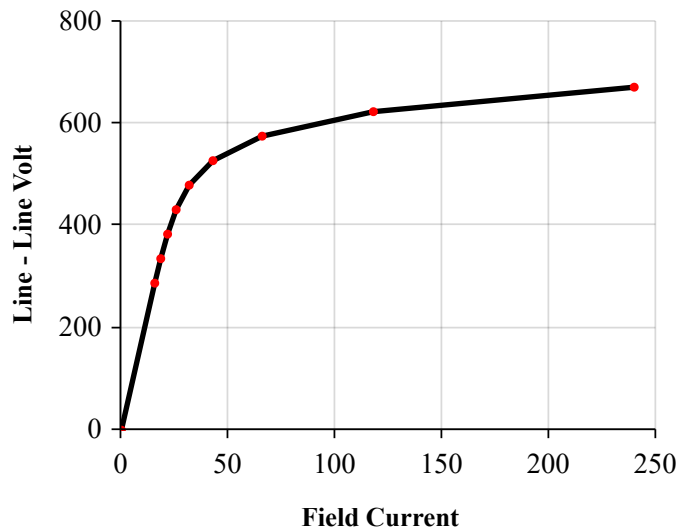

Short Circuit Curve

Short Circuit

Field Current	Armature Current
0.0	0
61.0	1,353
71.1	1,579
81.3	1,804
91.4	2,030
101.6	2,255
111.7	2,481
121.9	2,706
132.1	2,932
142.2	3,157

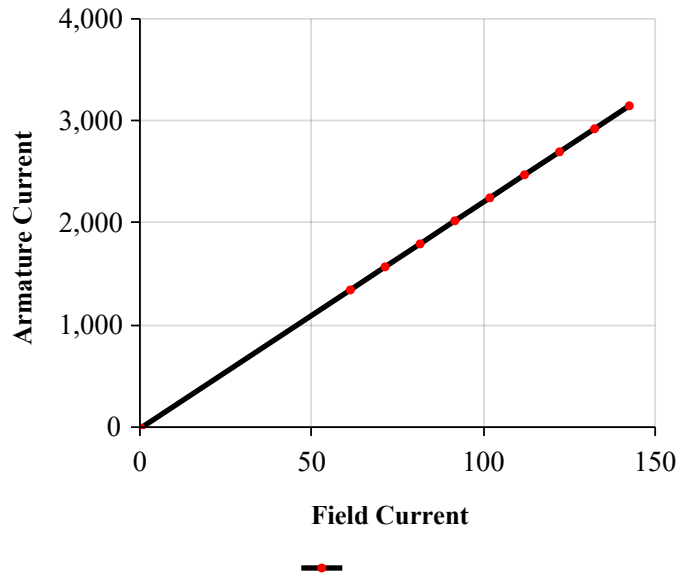

[Top...](#)

Selected Model

Engine: C32 **Generator Frame:** 1447 **Genset Rating (kW):** 1500.0 **Line Voltage:** 480
Fuel: Diesel **Generator Arrangement:** 6301134 **Genset Rating (kVA):** 1875.0 **Phase Voltage:** 277
Frequency: 60 **Excitation Type:** Permanent Magnet **Pwr. Factor:** 0.8 **Rated Current:** 2255.3
Duty: STANDBY **Connection:** SERIES STAR **Application:** EPG **Status:** Current
Version: 20259 /20253 /20259 /687196

Generator Output Characteristic Curves Zero Power Factor Curve

Zero Power

Field Current	Line - Line Volt
101.6	0
117.6	240
120.6	288
123.9	336
128.4	384
135.4	432
148.7	480
177.3	528
242.5	576
396.3	624

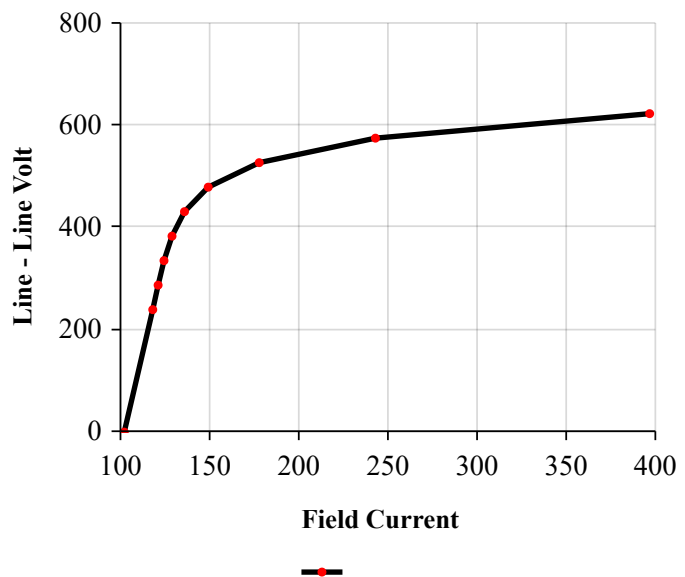

Air Gap Curve

Air Gap

Field Current Line - Line Volt	
0.0	0
15.4	288
18.0	336
20.5	384
23.1	432
25.7	480
28.3	528
30.8	576
33.4	624
36.0	672

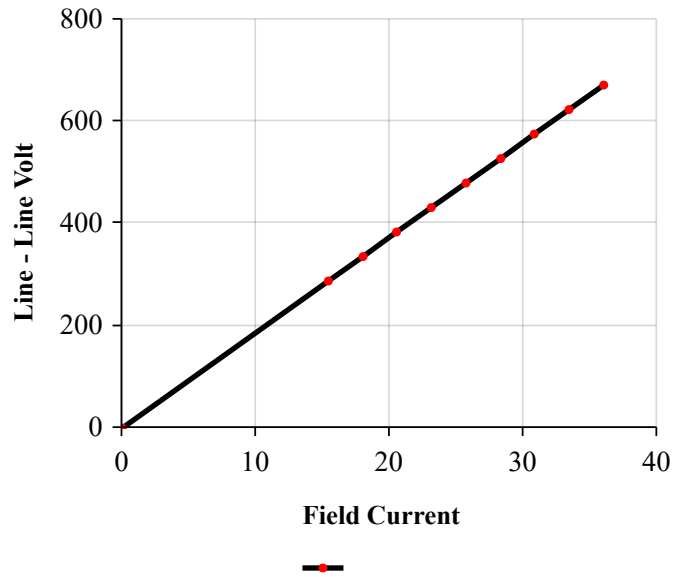

[Top...](#)

Selected Model

Engine: C32	Generator Frame: 1447	Genset Rating (kW): 1500.0	Line Voltage: 480
Fuel: Diesel	Generator Arrangement: 6301134	Genset Rating (kVA): 1875.0	Phase Voltage: 277
Frequency: 60	Excitation Type: Permanent Magnet	Pwr. Factor: 0.8	Rated Current: 2255.3
Duty: STANDBY	Connection: SERIES STAR	Application: EPG	Status: Current
Version: 20259 /20253 /20259 /687196			

Reactive Capability Curve

Operating Chart

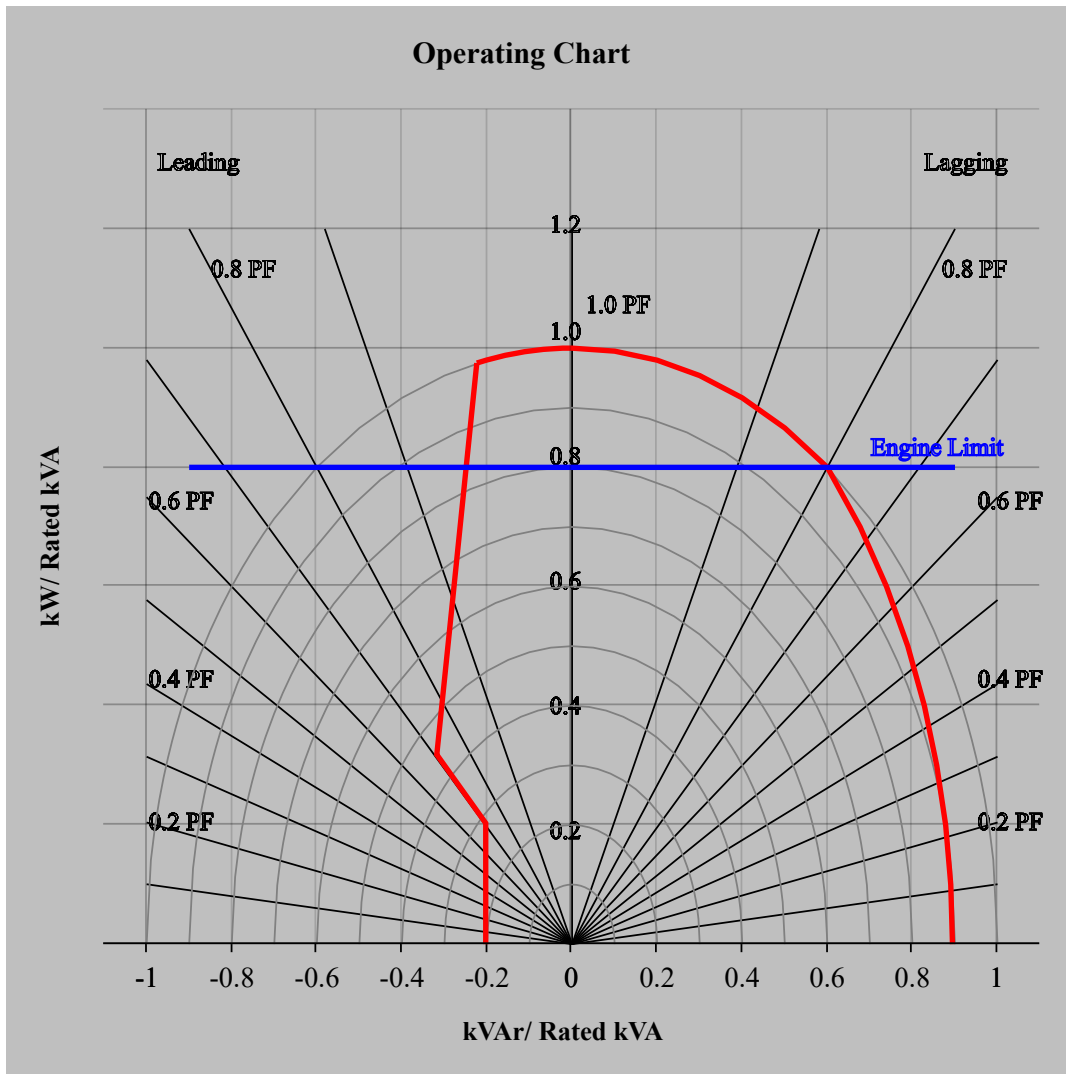

[Top...](#)

Selected Model			
Engine: C32	Generator Frame: 1447	Genset Rating (kW): 1500.0	Line Voltage: 480
Fuel: Diesel	Generator Arrangement: 6301134	Genset Rating (kVA): 1875.0	Phase Voltage: 277
Frequency: 60	Excitation Type: Permanent Magnet	Pwr. Factor: 0.8	Rated Current: 2255.3
Duty: STANDBY	Connection: SERIES STAR	Application: EPG	Status: Current
Version: 20259 /20253 /20259 /687196			
General Information			

DM7825 Caterpillar SR5 Generators (50 Hz, 60 Hz)
Data for 1400, 1600, 1700, 1800 and 1900 frames Caterpillar SR5
generators built by Leroy Somer - USA and Leroy Somer ☐ France.

Refer to DM7821 for explanation of all generator data in Technical
Marketing Information (TMI) except generator efficiency for which the
explanation is given below.

GENERATOR EFFICIENCY

Generator efficiency is the percentage of engine flywheel (or other
prime mover) power that is converted into electrical output. The
generator efficiency shown is calculated by the summation of all
losses method, and is determined in accordance with the IEC Standard
60034. The efficiency considers only the generator. There is no
consideration of engine or parasitic losses here.

Refer to DM7829 for low and medium voltage protective setting values a
nd limits.

Caterpillar Confidential: **Green**

Content Owner: Commercial Processes Division

Web Master(s): [PSG Web Based Systems Support](#)

Current Date: 4/15/2026, 3:29:08 PM

© Caterpillar Inc. 2026 All Rights Reserved.

[Privacy](#).

[Cookie Settings](#)

9. ANNOUNCEMENTS

Mr. Moore stated that the Street and Stormwater tax was passed. The election results were published March 3, 2026. The revenue from the tax will fund future projects related to streets and stormwater.

Mr. Moore explained that the Planned Unit Development article of the UDC was approved by the City Council, and the signage amendments will be presented later this week.

Mr. Moore said Scoopy's Café located in Downtown has closed, but a new business is moving in. Happy Cow Café is opening this upcoming Friday. Chairperson Mathos inquired if it is a local business. Mr. Moore replied it is and will offer cookies, brownies, take and bake pizza. Chairperson Mathos asked if Mr. Moore knew their hours. He replied they will be opening at 11:00 Friday morning with modified hours until around Memorial Day. The City is excited to have a new business located in Downtown.

Commissioner Mueller inquired about another café opening along 56 Highway. Mr. Moore replied that a building permit has been submitted, and they are working with the applicant to get it issued and their goal is to be open as soon as possible. Commissioner Draskovich inquired if they would have a drive thru. Mr. Moore replied he believes that is in the long-term plans.

10. ADJOURN

Commissioner Little moved to adjourn the meeting. Commissioner Mueller seconded the motion. The meeting was adjourned at 7:24 PM, 4-0

Submitted by Hailey Vaughn, Customer Service Representative II

DATE: May 5, 2026
TO: Planning Commission Members
FROM: Beth Linn, City Administrator
SUBJECT: DAMAC Digital Proposed Data Center

The City of Edgerton has received applications for Preliminary Plat (PP2026-0001) and Final Site Plan (FSP 2026-0002) for DAMAC Digital.

This Project is located in an **existing building** at 31800 West 196th Street in Logistics Park Kansas City. The property is currently zoned Logistics Park (L-P) which allows data centers as a permitted use; therefore no annexation or rezoning required.

With the recent boom in data center construction, we know that residents in the area will have questions about the Project that would not necessarily be included in review of either preliminary plat or site plan. With that in mind, Staff included some of the most frequently asked questions related to this project below. Additionally, Staff has enclosed the following information from other agencies:

- Frequently Asked Questions submitted by DAMAC Digital for this Project.
- Evergy Data Center Facts and FAQs
- Data Centers in the KC Region published by Kansas City Area Development Council (KCADC)

Q: Will this project use up or contaminate my water supply?

NO. DAMAC Digital is using advanced technology called a closed-loop cooling system. This type of cooling system is very different from systems in older data centers.

A closed-loop system protects the City's water resource. After the initial one-time fill of the system, there is no use of the public water supply for the system. This advanced technology is designed for maximum water efficiency, typically achieving a Water Usage Effectiveness (WUE) near zero.

Q: Will my electric bill be higher because of the Project?

NO. Recently Evergy put out a DATA CENTER FACTS AND FAQs handout for customers. This handout is enclosed after this memo. The handout included this question and many others. In the handout, Evergy states that "data centers reduce future rate increases for existing customers by paying a significant portion of the ongoing costs to operate and maintain the electrical grid." Evergy also has more information about data centers on their website at www.evergy.com/landing/energy-value.

DAMAC Digital is paying for 100% of all direct costs for electrical service to the data center. The company is funding construction of dedicated electrical infrastructure to serve the facility, including an on-site switching station and upstream grid updates.

Q: Will I be able to hear a significant hum from the building?

NO. This facility will be engineered with strict attention to noise management, with measures designed to meet or exceed noise regulations.

The closed-loop cooling system is significantly quieter than older technology. In fact, when we measured the decibel level at the property line for similar projects, we couldn't hear anything beyond normal ambient noise like wind blowing and birds chirping. Standing near the property line, this advanced technology is quieter than a car driving by, your home's exterior air conditioning unit, or even normal conversation. Especially for this Project, traffic travelling on Interstate 35 will be louder than noise produced at this building.

Q: What about noise from the generators?

You will hear occasional noise outside the building from periodic testing of the back-up generators, which are necessary for reliable operation. Advanced noise-reduction technologies, including sound attenuated enclosures and specialized exhaust systems, are used to minimize sound during these brief testing periods.

Back-up generators are necessary to provide emergency power during an outage. These generators will be permitted by Kansas Department of Health and Environment (KDHE) on behalf of Environmental Protection Agency (EPA). That permit regulates the emission, noise level and run time of the generators. Generator manufactures have also developed new technology to reduce noise and vibration including the use of sound-attenuated enclosures, specialized exhaust systems and sound-absorbing materials within the unit.

Chillers are used in data centers to remove heat by servers to prevent overheating. Advanced acoustical technology is used to muffle sound at the source, minimizing disruptive noise.

Q: Will the lights from the building shine in my bedroom window?

NO. This facility must comply with all applicable lighting standards for the L-P zoning district. Lights can be used to illuminate the building and are directed downward and away from residential properties. For this Project, this means light cannot extend beyond the property line onto the property to the west and to the south. While you may be able to see a light pole or fixture from your window, it should not cast a shadow when you are on adjacent property.

Q: What will the building look like?

This is an existing building. DAMAC Digital will add additional equipment, fencing and walls to the building. The Final Site Plan application will include architectural renderings of the building which can be found in this Planning Commission packet.

**INFORMATION PROVIDED
BY DAMAC DIGITAL**

May 5, 2026

City of Edgerton

Beth Linn, Administrator
Mayor Donald Roberts
404 East Nelson
Edgerton, Kansas 66021

Edgerton Planning Commission

Tina Mathos, Chair
Jeremy Little, Vice Chair
Jordyn Mueller, Secretary
Adam Draskovich, Commissioner
Ray Soemer, Commissioner

RE: Proposed West 196th Street Data Center Project

On behalf of the Developer of the proposed data center located at 31800 West 196th Street, thank you for your time and consideration of the enclosed site plan submittal.

In advance of a public announcement, we have included a brief project overview along with a set of frequently asked questions and answers regarding both the project and the Developer to assist with your review and to provide additional context. These materials are intended to supplement the site plan drawings and support an efficient and informed evaluation of the proposal.

The project is being designed with consideration for applicable zoning and development standards, as well as compatibility with the surrounding area and the long-term objectives of the Village.

We appreciate our continued partnership with Edgerton and the opportunity to present the project next week.

Thank You,
The Project Team

Data Center Project FAQ

Q: What are data centers, and why do they matter?

A: *Data centers are the physical backbone of our digital lives. They are secure facilities that house the servers, networking equipment, and cooling systems that store and process the data behind virtually everything we do online, from streaming video and managing bank accounts to powering 911 dispatch systems, electronic health records, GPS navigation, and cloud-based business tools.*

While data centers are increasingly in the public eye for their role in supporting artificial intelligence (AI) and cloud computing, they have quietly underpinned the apps and services we've relied on every day for years. As demand for digital services continues to grow, modern data center facilities are a critical part of the infrastructure that keeps communities and economies connected.

Q: Who is the Developer?

A: *The Developer is the digital infrastructure division of an international real estate developer and owner. The company has data center projects under various stages of development in 12 countries. Our company designs, builds, and operates large-scale data center facilities that serve major technology and enterprise customers.*

Q: What should neighbors expect during construction?

A: *As with any large-scale construction project, there will be periods of increased activity near the site, including construction vehicle traffic, equipment noise, and related disruption. All construction work will be performed in accordance with local noise regulations and permitted working hours, and relevant schedules and updates will be communicated to the community as the project progresses.*

The Developer is committed to being a considerate neighbor during the construction phase and will coordinate with local authorities to manage impacts on surrounding roads and neighboring industrial areas. Though the site will undergo internal construction and renovations, the exterior will remain virtually unaltered as the project is taking a sustainable approach by retrofitting an existing 400,000-square-foot warehouse structure within an established commercial park. Residents with questions or concerns during construction will have a clear point of contact for raising them.

Q: Who will the data center serve?

A: *The facility is being designed to serve leading technology and enterprise customers with large-scale computing and data storage needs. The Developer is in active discussions with prospective end-users and will share additional details as they become available.*

What Neighbors Can Expect

The project reflects a straightforward commitment: to build and operate world-class digital infrastructure in a way that strengthens the communities where it works. That means designing to meet or exceed requirements on noise, lighting, and environmental performance; investing in local workforce and economic development; and maintaining open, ongoing dialogue with neighbors and local officials throughout every phase of the project.

Water: Advanced cooling technology selected to minimize water consumption across all operating conditions.

Energy: Dedicated power infrastructure funded by the Developer, with no direct impacts on power supply or costs.

Noise: Site-specific acoustic design, low-noise equipment, and building setbacks engineered to meet or exceed local codes.

Lighting: Security lighting oriented downward and contained within property boundaries to minimize the impact to the nearby area.

Traffic: Low-volume operations with infrequent deliveries and staggered employee shifts.

Community: Ongoing engagement with local organizations, transparent communication, and investment in Edgerton's long-term growth.

Q: What will it be like living near the data center?

A: Data centers are among the quietest and least disruptive types of commercial development a community can host. They produce no manufacturing byproducts, require no heavy freight logistics, and operate with a small on-site workforce distributed across around-the-clock shifts. The result is a facility with minimal vehicle traffic, no large shift-change surges, and limited activity visible from surrounding properties.

Though the zoning is prescriptive for commercial uses, the Developer is committed to incorporating landscaped buffers and appropriate setback distances from neighboring properties to minimize potential disruptions from day-to-day operations, which take place almost entirely inside the buildings. The Developer is designing the facility with the surrounding community in mind and will be responsive to neighbor feedback throughout the life of the project.

Q: Will there be noise from the data center?

A: The facility is being designed with strict attention to noise management. The Developer's acoustic design process incorporates site-specific noise modeling developed in coordination with engineering specialists and local authorities, ensuring that sound levels at sensitive locations, particularly adjacent properties, are identified and addressed at the design stage rather than after construction.

On-site activity is relatively low volume. The primary sound sources are cooling equipment and backup generators. Cooling equipment noise is managed through a combination of acoustic enclosures, barriers, low-noise equipment selection, and strategic building and equipment orientation. Backup generators are designed to run only during actual power outages and for brief periodic testing required by code. In practice, total generator operating time is expected to amount to only a few hours per year. These measures are designed to ensure that noise levels at the property boundary meet or exceed local code requirements.

Q: What about light pollution from the data center?

A: All exterior lighting will be designed to provide necessary security coverage while respecting the surrounding neighborhood. Fixtures will be oriented to cast light downward onto the site rather than outward or skyward, and lighting layouts will be engineered to contain illumination within the property boundaries. The design will also incorporate dimming controls and motion-activated sensors to reduce unnecessary lighting during low-activity periods, as well as modest fixture heights that limit the reach of glare. The facility will comply with all applicable local lighting regulations.

Q: Will the data center increase traffic in the area?

A: Data centers generate very little ongoing traffic compared to similarly sized commercial or industrial developments. Once operational, the facility will have a small on-site workforce spread across rotating shifts, and routine deliveries are uncommon.

During the construction phase, there will be increased construction vehicle traffic in the area. The Developer and its contractors will coordinate with local authorities to manage construction traffic and minimize disruption to residents and local roadways.

Q: Should the community be concerned about air-quality impacts?

A: *During normal day-to-day operations, the facility does not produce ongoing air emissions. The equipment inside the buildings is electronic and the cooling systems are mechanical. The only equipment with potential air-quality considerations is backup generators, which run only during power outages or brief periodic testing required by code. In practice, total generator operating time is expected to amount to only a few hours per year.*

All backup generation equipment will be permitted and monitored by the EPA Region 7, which includes Kansas. The Developer has engaged environmental specialists to assess and mitigate any potential impacts, and their findings will inform equipment selection and operational standards to ensure the facility meets or exceeds all applicable air-quality regulations. The Developer is also monitoring the development of cleaner generator fuel alternatives, including hydrotreated vegetable oil (HVO) blends and longer-term, hydrogen-based technologies, and will evaluate these options as the facility's fuel procurement strategy is finalized.

Q: Is the data center safe? What about security?

A: *Data centers are designed to the highest safety and security standards. The facility will include 24/7 on-site security personnel, perimeter fencing, controlled access points, and video surveillance. These security measures are standard across the industry and are required to protect the sensitive computing infrastructure housed inside.*

From a community safety perspective, data centers do not store hazardous materials, do not involve chemical processing, and present no explosion or contamination risk. The facility will comply with all applicable fire codes and safety regulations.

Q: How much water will this data center use?

A: *Water efficiency is a central element of the facility's design. The facility cooling strategy is built around minimizing water consumption, with closed-loop technology as a core component. A closed-loop system is a fully sealed, recirculating system that transfers heat efficiently while minimizing water loss and avoiding contamination. It operates in a sealed circuit, similar in concept to radiant floor heating in residential buildings, significantly reducing water use compared to conventional cooling methods. The facility's overall cooling approach may incorporate additional technologies, as needed, to optimize performance across varying conditions, but water efficiency will remain a guiding design priority.*

The data center will be connected to the public water supply but will not use extensive water, other than typical back-of-house functions such as restrooms and break rooms, at the same intake level as a standard warehouse facility. Some public water will be required up front for start-up, but the balance of cooling system water will remain in the closed-loop system and will not require additional public water supply. No water and sewer infrastructure upgrades are needed.

For context, the data center industry accounts for a small fraction of U.S. freshwater consumption, and modern facilities are continuously improving efficiency through innovative cooling technologies.

Q: What impact will the data center have on energy resources and electricity rates?

A: *The Developer is funding the construction of a dedicated on-site switching station and substation, ensuring no cost is passed to local ratepayers and enhancing grid reliability for the surrounding area. Research has consistently shown that data center development generally does not drive increases in local electricity rates; rate changes are more commonly linked to factors such as grid maintenance costs, weather events, and fuel prices. The Developer intends to evaluate all available renewable procurement pathways as the facility moves toward operations.*

Q: Will this data center raise my electricity bill?

A: *No. the Developer is funding the construction of dedicated electrical infrastructure to serve the facility, including an on-site switching station and upstream grid upgrades. These costs are borne by the company, not local ratepayers.*

The Developer will pay 100% of all costs for electrical service to the data center. Residents' and local businesses' power availability and rates will not be affected. Evergy is required to have enough power to meet its highest load plus a 15 to 38% reserve margin, depending on the season. Evergy cannot add new customers without already having the capacity to provide the energy they need and keep a higher margin in reserve. Moreover, industry research has consistently found that data center development does not drive increases in residential electricity rates. In many cases, the infrastructure investments made by data center developers can improve grid reliability for the surrounding community.

Q: What will the project's overall environmental impact be?

A: *Environmental responsibility is a priority in the design and operation of this facility. The Developer is working to minimize its environmental footprint through efficient cooling technology, thoughtful site design, and adherence to internationally recognized effectiveness metrics for power, water, and carbon usage.*

Rather than select a greenfield site, the company has opted to retrofit an existing 400,000-square-foot warehouse facility within a legacy industrial zone. By choosing to repurpose existing resources, the Developer is prioritizing sustainable solutions that invite communities to take advantage of growing economic opportunities within and related to the data center industry.

The company will meet or exceed all applicable local, state, and federal environmental regulations. The Developer's compliance and governance framework is designed to ensure that its operations and business activities align with regulatory requirements as well as responsible corporate practices.

Q: How many jobs will the project create?

A: *The economic impact of this project extends well beyond the permanent on-site workforce. The construction phase alone requires a broad range of skilled trades, including civil and structural engineers, electricians, HVAC technicians, mechanical engineers, plumbers and pipefitters, ironworkers, carpenters, concrete workers, roofers, glaziers, fire-suppression specialists, low-voltage cabling technicians, security system installers, landscapers, and project managers and site supervisors. This diversity of trade categories means the construction phase generates employment opportunities across a wide range of skill levels and certifications.*

Once operational, the facility will employ full-time technical and operations staff through highly skilled, well-paying roles in areas such as data center engineering, network operations, security, and facilities management, providing considerable economic and employment opportunities for individuals in Edgerton.

Q: Will residents have access to these jobs?

A: Yes. The Developer intends to hire from the local and regional workforce for both construction and permanent operations roles. Many data center positions, including technician roles, typically require trade certifications or six to 12 months of specialized training rather than a four-year degree, making them accessible to a broad range of candidates.

The Developer is exploring partnerships with area educational institutions and workforce development organizations, such as Gardner-Edgerton School District USD 231 and Johnson County Community College, to help connect Edgerton residents with the skills and training needed for careers in data center construction and operations. More details on these programs will be shared as they are finalized.

Q: How else will this project benefit the community economically?

A: A capital investment of this scale generates substantial economic benefits for the host community. These typically include significant sales tax and property tax revenue that supports local infrastructure, like storm water systems and streets, and school districts; direct spending with local businesses and contractors during construction and ongoing operations; and the potential to attract additional technology-sector investment to Edgerton.

Beyond direct employment, the facility generates significant indirect and induced economic activity through local procurement of goods and services, contractor relationships, employee spending in the local economy, and property tax contributions that fund public services. Third-party economic impact studies of comparable facilities consistently find that the total economic footprint, including these indirect and induced effects, is a meaningful multiple of the direct employment figure. An extensive economic and fiscal impacts study to assess the benefits of the proposed project is being conducted, and results will be detailed in future releases.

Q: How will this project affect nearby property values?

A: Large-scale infrastructure investments of this kind have historically been associated with stable or increased property values in surrounding areas, driven by improved infrastructure, increased economic activity, and growth in local tax revenue that funds public services and infrastructure. The investment and associated improvements represent a significant commitment to the area's long-term development.

Q: Will the Developer be a good neighbor?

A: The Developer is committed to building a long-term, positive relationship with the Edgerton community. That commitment starts with how the facility is designed, with careful attention to noise, lighting, traffic, and environmental impact, and extends to how the company operates as a member of the community.

The Developer plans to engage with local organizations and nonprofits, contribute its employees' time and resources, and maintain open, transparent communication with residents throughout the development process and beyond. The company's goal is not simply to renovate an existing facility in Edgerton, but to be a meaningful contributor to the community's long-term well-being.

Q: Where can additional information about this project be found?

A: The Developer will keep the lines of communication open throughout duration of this important project. The Developer will launch a project website during the first phase of development and will be shared in a project announcement.

**INFORMATION PROVIDED
BY ENERGY**



Data Center Facts and FAQs

In the fall of 2025, the Missouri and Kansas utility commissions approved a special electric rate that establishes criteria that all large energy users over 75 MWs (including data centers) must meet before connecting to Evergy's electrical system. Here are some key points to remember about data centers, as Evergy prepares to welcome these new large users to its system.

Data Center Facts

- Data Centers must pay 100% of all direct costs for service to their facilities.
- Data centers must pay a premium rate, that is as much as 20% higher than existing large customer demand rates, to help pay for new investments in generation and transmission and protect existing customers from shouldering those costs.
- Data centers reduce future rate increases for existing customers by paying a significant portion of the ongoing costs to operate and maintain the electrical grid.
- Data centers must sign long-term contracts (up to 17 years) with significant early cancellation penalties to provide stability and protect existing customers.
- Data centers have a monthly MINIMUM BILL that ensures they pay regardless of whether or not they use the energy.
- Data centers SHARE in the cost of utility upgrades, which will happen with or without data centers.
- Data centers PROVIDE millions of dollars in local revenue for our cities, schools and services.
- Data centers ENABLE more investment in the digital economy.
- Data centers CREATE JOBS – construction jobs, permanent jobs and ongoing maintenance jobs, which provide a continual economic boost to surrounding communities.

- Data centers will be valuable PARTNERS for community priorities and projects.
- Data centers are vital to NATIONAL SECURITY by ensuring the United States has enough computing power and storage to operate vital businesses with military and financial systems and not fall behind other countries in the development of artificial intelligence (AI) capabilities.

Frequently Asked Questions

Does Evergy have the power to serve these new large customers, and will it lead to brownouts?

Evergy is required to have enough power to meet its highest load plus a 15-38% reserve margin, depending on the season. In other words, Evergy cannot add new customers without already having the capacity to provide the energy they need AND keep a higher margin in reserve. That higher margin represents the amount of back-up power Evergy must have to guard against unplanned conditions or events on the regional power grid. If the grid was in danger of becoming overloaded, large customers and data centers would be called on to reduce their energy usage. Evergy's demand response programs help reduce power needs at time of high usage to protect the grid and to manage cost. Evergy averages fewer than 10 days per year where it is required to be in heightened alert status because of strains on the grid. Only once, during Winter Storm Uri in 2021, have we had temporary, controlled interruptions in service.

Will data centers increase MY power costs?

No, data centers reduce future rate increases for existing customers by paying a significant portion of the ongoing costs to operate and maintain the electrical grid.

Operating and maintaining the electrical grid is costly and increasing regardless of large loads. To ensure that data centers bring price and service benefits to our

existing customers, Evergy was proactive and established a new rate for large data centers. This new rate charges data centers a higher rate than other industrial customers. That premium is then applied to existing customer bills to help reduce future rate increases. Also, given the large volume of electricity used continuously by these types of large customers, they will pay MORE of the ongoing costs of operating, upgrading and maintaining the electrical grid. Adding new users or growing Evergy's base of large industrial customers is the best way to hold down costs for everyone.

What are the benefits of data centers for my community?

A data center can increase the amount of property and other tax revenues a community sees without a similar drain on services. Additionally, many communities have a franchise fee assessed on electric usage that can generate millions of additional dollars to fund city services. It also brings in valuable community partners to invest in job training and other community priorities.

Do data centers create jobs?

Yes. While the number of full-time, permanent jobs is smaller than a large manufacturing facility, there is a significant benefit. Thousands of construction jobs are created while the facility is being built. Additionally, many data centers refresh their equipment every three years, adding to the ongoing benefit in jobs and investment at these facilities. That's to say nothing of jobs created by restaurants, suppliers and others that count on the increased traffic.

Do data centers attract other businesses?

AI will be a significant catalyst for the future economy. More of everything that we do will depend on a direct data connection and two-way communication with the internet. Surgery, robotics, automated vehicles, and more, will increasingly depend on immediate interpretation of data and the translation of that data to action. Data centers are the infrastructure of the future that enable both AI and businesses that use it.

And, proximity matters. Having robust data center infrastructure here means the companies in our region will be first in line for the economic activity AI enables.

Do data centers threaten water supply?

Newer data centers are moving toward closed-loop cooling, which dramatically reduces water use by reusing water. In addition, cooling that does not use water, like

free-cooling and air-cooling methods, is becoming more common. The impact our water systems are seeing from data centers will continue to shrink as technology is brought to bear on the problem. For example, Meta has said it will be water positive by 2030- meaning it restores more water than it uses.

How much land do data centers use?

Data centers require a footprint of about 10 to 250 acres. Each acre generates millions in economic activity, supports digital services and enables cloud computing. The value per square foot is extremely high. Many data centers are sited in industrial and commercial areas that are used for economic development projects. In addition, data centers frequently move into vacant commercial spaces that housed different industries- revitalizing parts of our community.

Don't data centers increase the need for large transmission lines?

All large projects a utility adds to its system require additional transmission capacity. Data centers usually locate near existing infrastructure, which minimizes local impacts. Data centers directly pay for lines constructed specifically to serve them.

What about the incentives data centers might get from local governments?

Data centers attract billions in investment and help create construction and permanent jobs. Missouri and Kansas both now have policies that require minimum investments and job creation standards for data center incentives. These incentives are similar to other types of economic development. Ultimately, it's up to state and local leaders to decide what types of incentives make sense and at what level.



Kansas regulators OK plan to shield home power bills from data center costs

KWCH, Nov. 6, 2025

KANSAS REFLECTOR

New Kansas rules set guidelines for data centers, big power users to protect smaller customers

NOVEMBER 6, 2025

**INFORMATION PROVIDED
BY KCADC**

DATA CENTERS

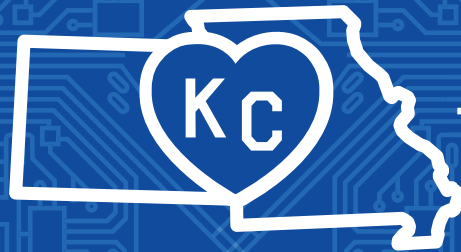

IN THE KC REGION



What are Data Centers?

Data centers are facilities equipped with computer servers and networking systems that process and store the data powering our daily lives. These services include essential and everyday communications – such as email and video calls, streaming and social media – but much more than that, data centers are the backbone of the economy providing resilience and security for defense, education, emergency services, financial services, healthcare, the global race for AI... and so much more.

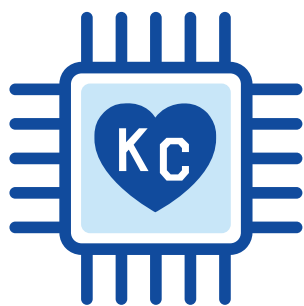

The KC region is primed to impact the exponential growth of digital services and cloud computing. Today, nearly **50 data centers** operate in the Kansas City region.¹ These facilities range from a few thousand square feet in size to large campuses operated by companies like Meta and Google.

COMMUNITY BENEFITS

Strengthening Local Tax Bases | Data centers generate substantial property tax revenue due to their large physical footprint and high-value equipment. Two recent projects illustrate the scale of potential impact:

- **Google** is doubling down on Missouri. Following its 2024 debut, Google announced a second Kansas City data center, committing to cover full energy costs for both campuses. Google fuels more than just data; it enables the development of new, carbon-free energy to the grid and supports local STEAM and trade programs within the North Kansas City School District.
- Similarly, **Meta's** data center is projected to contribute approximately \$1.5 million in taxes to Smithville Schools in 2026, with payments expected to grow annually and potentially exceed \$40 million per year based on early estimates.³

Minimal Strain on Public Services | Compared to other industrial developments, data centers place limited demands on roads, schools and public safety resources, while still contributing significant tax revenue.

Diversifying the Regional Economy | Data centers help broaden the Kansas City region's economic base, reducing reliance on any single industry and strengthening resilience during economic downturns.

Revitalizing Underutilized Buildings | Data center projects can transform vacant or underused buildings into productive assets. Lambda, a new \$500 million data center near KCI, for example, is converting an unoccupied building into a modern facility that will significantly expand the local tax base.⁴

Investing in Community Partnerships | Major data center operators are often active community partners, supporting schools, hospitals and nonprofit organizations. Meta has contributed more than \$1 million to schools and nonprofits in Clay County, Platte County and Kansas City, Missouri.⁵ Google has donated \$120,000 to the North Kansas City School District⁶ and has launched its STAR (Skilled Trades and Readiness) program in Kansas City to strengthen the skilled trades pipeline, particularly among underrepresented communities.⁷



Utility Requirements and Protections

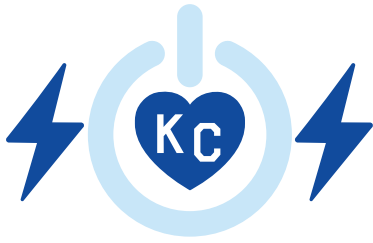

Data centers require large, consistent amounts of **electricity** to operate. As the Kansas City region’s largest energy provider, Evergy has implemented a dedicated rate class in both Kansas and Missouri to ensure that data centers cover the cost of the electricity they consume, as well as the infrastructure needed to deliver it — a structure designed to protect residential ratepayers.



Water use varies by facility and cooling technology. Some data centers rely on closed-loop systems that are initially filled and then replenished only to offset evaporation. Increasingly, operators are moving toward waterless cooling technologies. Kansas City’s proximity to the Missouri and Kansas Rivers also enables utilities to reliably supply water when required.

FACT CHECK

Data center employees are highly skilled and well compensated.

This is an eco-shaping moment that advances local innovation, talent and industry strengths. Data centers consistently pay their employees above average wages. Data center projects also generate thousands of construction and professional-service jobs — an area where Kansas City excels thanks to firms like JE Dunn Construction, Black & Veatch, Burns & McDonnell, Henderson Engineers, MarkOne Electric, U.S. Engineering and GBA Builders. Meta’s project in the Northland, for example, is expected to support approximately 2,830 jobs annually during its 11-year buildout and create 326 full-time operational positions afterward.⁸

Data centers are not freeloaders. While large-scale facilities may receive incentives to invest in a community, they often transform lower value sites into high-impact assets, increasing property taxes, employment and local economic activity. The States of Kansas and Missouri have identified data centers as a target industry and aligned incentives to support their growth.

Data centers won’t end up on every corner. Regional power capacity and available industrial land naturally limit the number of data centers that can be built. Kansas City is expected to reach a practical saturation point well before every district sees one.

MOVING FORWARD

Target the Right Sites. Certain Kansas City locations are better suited for data center development. Industrial-zoned sites are preferred, and communities should ensure zoning codes are up to date and account for data center uses.

Plan for Impact. Community leaders can strategically invest new tax revenues from data centers — whether in infrastructure, parks, public safety, or reducing property taxes — to maximize local benefit.

Tie Incentives to Performance. Municipalities can structure incentives to be performance-based, ensuring data centers meet their commitments, and communities receive the full return on their investment.

¹ datacentermap.com

² <https://www.desotoks.us/465/Data-Center-Campus-Project>

³ <https://www.desotoks.us/465/Data-Center-Campus-Project>

⁴ <https://www.bizjournals.com/kansascity/news/2025/11/10/lambda-ai-factory-data-center-evergy-lincoln.html>

⁵ <https://about.fb.com/news/2025/08/metaskansas-city-data-center/>

⁶ <https://www.kctv5.com/2024/11/14/google-partners-with-kcps-expand-educational-opportunities-with-funding/>

⁷ <https://missouripartnership.com/google-announces-1-billion-data-center-in-kansas-city-missouri/>

⁸ <https://www.dropbox.com/scl/fi/oy36zr54ugfnia4w86upx/Golden-Plains-Technology-Park-Data-Center-Development-Impacts.pdf?rlkey=7zqdluk6iu1mzyt3iwbwbhfwx&st=zeedm7fk&dl=0>

FINAL SITE PLAN FOR EDGERTON PROJECT

Application FSP2026-0002
31800 W. 196th Street

QUICK FACTS

PROJECT SUMMARY AND REQUESTED APPROVALS

The Applicant is requesting approval of a Revised Final Site Plan for 31800 W. 196th Street.

Owner and Applicant

DAMAC Digital Solutions Kansas, LLC, property owner, represented by Mark Breuer, Schlagel Associates

Zoning and Land Use

L-P (Logistics Park) and is currently developed with a warehouse.

Parcel Size

53.79± acres

Staff Report Prepared by

Zachary Moore



1. Proposal

The Applicant is requesting a Revised Final Site Plan application for exterior improvements to a previously developed property to accommodate a proposed data center. Improvements to the property include the addition of two (2) new approximately 2,053 square foot medium-voltage (MV) intake buildings, a guard shack, outdoor generators, mechanical equipment screening, an electrical substation, and an Evergy electrical switching station. These site improvements are proposed to be made to the subject property which was originally developed with a 378,038 square foot warehouse in 2016. The total building square footage as proposed will total in 382,924 square feet.

Generators are proposed along the east and west sides of the proposed building in 'pods' of 15. Both the east and west sides of the existing building will have two 'pods', each of which will be screened from public view with a wall and will be gated.

North of the existing building, the Applicant is proposing electrical improvements to be made to previously undeveloped land. On the western portion of the land to the north of the building, an electrical switching station to be owned and maintained by Evergy is proposed, while the eastern portion of the property is proposed to include a developer owned and maintained electrical sub-station.

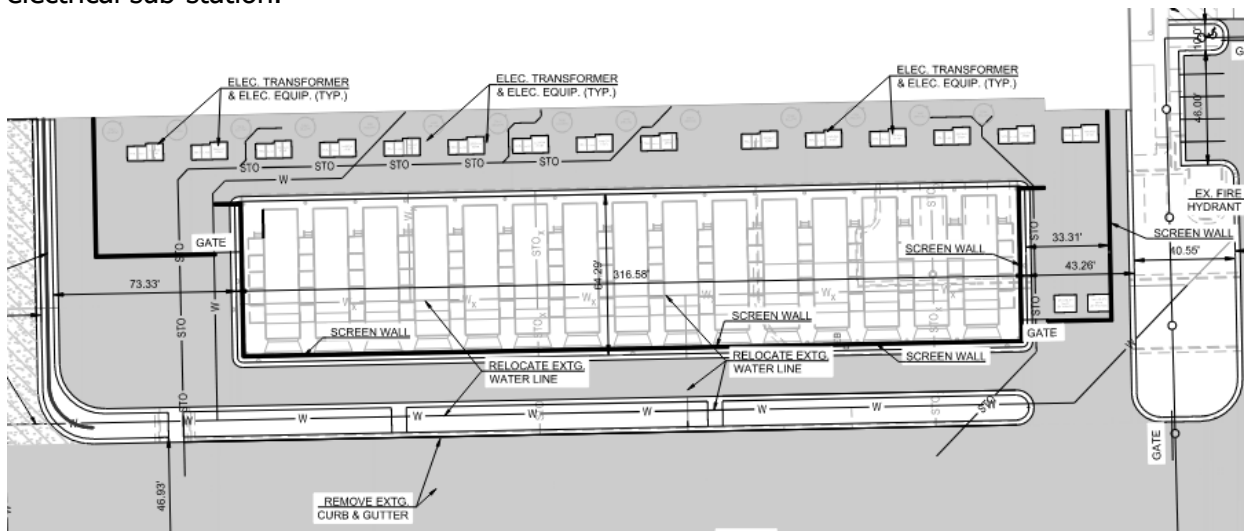

Figure 1 - Example of Generator 'Pod' (SW Corner)

2. Subject Site History

The three (3) parcels included in the Final Site Plan are noted on the map on the following page.

Parcel 3 was annexed into the City on March 27, 2014 (Ordinance No. 969) and later rezoned to *L-P, Logistics Park* District on December 11, 2017 (Ordinance No. 986). Additionally, the following applications have been approved for Parcel 3:

- Preliminary Plat PP-10-08-14
 - Approved by the Planning Commission on November 4, 2014
- Preliminary Site Plan PS-10-08-14
 - Approved by the Planning Commission on March 10, 2015
- Final Plat FP2016-01

- Approved by the Governing Body on April 14, 2016
 - Showed three (3) lots and one (1) tract. Each lot developed with a warehouse.
- Final Site Plan FS2016-04
 - Approved by the Planning Commission on April 19, 2016.
 - Final Site Plan FS2016-04 outlines the requirements that the parcel is currently developed under.

Parcels 1 and 2 were annexed into the City on August 9, 2018 (Ordinance No. 1087) and later rezoned to *L-P, Logistics Park* District on October 25, 2018 (Ordinance No. 1091). There have not been any further planning or zoning applications submitted for Parcels 1 and 2.

3. Zoning Standards

A. **Land Use** – The proposed use of a data center is considered to be “Warehousing/Distribution centers, including trucking and courier services; public warehousing and storage; and motor freight transportation terminals and maintenance facilities”, which is a use permitted by right in the L-P District. Other permitted uses within the L-P District similar to data center include internet service providers; sale, servicing, and repair of electrical and other electronic devices; radio and television broadcasting stations.

B. Setback, Yard and Area Regulations

1. **Minimum Open Space:** A minimum of 50% of a property must be open space for any property zoned L-P District. The subject property totals 2,343,242 square feet in size, of which, approximately 1,579,168 square feet (67.39%) is existing open space. The proposal includes a total of 1,219,417 square feet (52.04%) of open space proposed at build-out, compliant with the L-P District open space requirement.
2. **Maximum Building Height:** The L-P District has a maximum height allowance of 110 feet. The existing building height is not proposed to change with this application, and will remain at 46 feet. The new MV intake buildings are each proposed to be 20 feet in height, and the new guard shack is proposed to be 13 feet and 6 inches in height. The wall proposed to screen the generators and mechanical equipment is proposed to be 35 feet in height where adjacent to the generators, and will step down to 25 feet at the north and south portion of each pod of generators. Each of the new structures on the property will be compliant with the maximum height allowance in the L-P District.
3. **Floor Area Ratio (FAR):** The maximum FAR allowed in the L-P District is 3:1. The proposed development has a FAR of 0.16:1, which is less than the maximum allowed by the Unified Development Code (UDC).
4. **Building Coverage:** The maximum building coverage permitted in the L-P District is 50%. The total square footage of all buildings (existing and proposed new) is 382,924

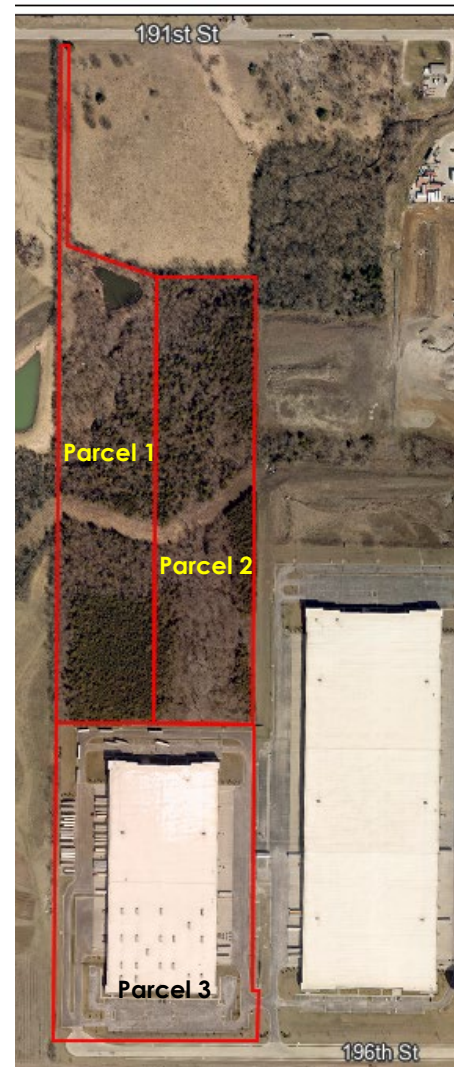

- square feet, which is 16.34% of the overall subject property, which is less than the maximum allowed by the UDC.
5. Setbacks:
 - a. Front: The minimum front yard setback in the L-P District is 50 feet.
 - a. The existing building is approximately 180 feet and 3 inches from the front property line, and is not proposed to be modified. The new proposed guard shack in the southwest corner of the property will be set back from the front property line by approximately 95 feet. Each building on the property meets or exceeds the required minimum front yard setback.
 - b. Side: The minimum side yard setback in the L-P District is 25 feet for side yards not adjacent to a residential district (east) and 100 feet for side yards that are adjacent to a single-family residential district for buildings greater than 45 feet in height (west).
 - a. The proposal exceeds the minimum side yard setback requirements by providing an approximately 45-foot setback to the eastern property line from the screen wall, and an approximately 110-foot setback to the western property line.
 - c. Rear: The minimum rear yard setback in the L-P District is 25 feet for yards not adjacent to a residential district.
 - a. The northern property line is approximately 1,227 square feet from the northernmost edge of the proposed electrical substation and approximately 1,811 feet from the northernmost edge of the eastern MV intake building, exceeding the minimum UDC requirements.
 6. Building Separation: All buildings in the L-P District must have a minimum building separation of 20 feet.
 - a. The two MV intake buildings are separated from the main building by approximately 38 feet and the guard shack is separated from the main building by approximately 65 feet, exceeding the minimum UDC requirements for building separation.

C. Architectural Design Guidelines

The main building on the subject property was originally approved and developed under the terms and conditions of Final Site Plan application FS2016-04, with which the architecture for the main building was approved. The Applicant is proposing that there be no architectural modifications to the existing building on site, therefore, the building may remain as is without modifications being required.

The two (2) MV intake buildings and new guard shack are considered accessory structures, and pursuant to UDC, Section 5.2.G.8, must have a façade similar in character with the façade of the main building, including the utilization of similar fenestration and materials.

1. Large Expanses: Building façades greater than 100 feet long facing public right-of-way or residential property must break up the façade by using a minimum of three (3) architectural elements provided in UDC, Section 5.2.J.2.
 - a. Each façade of each of the three (3) new accessory structures on the subject property are less than 100 feet in length, therefore, elements to break up the façade as indicated above are not required.
2. Building Materials: Buildings in the L-P District must consist of materials including but not limited to stone, brick, glass block, tile, cast metal, cast or cultured stone, concrete

- (tilt-up walls), glass, or a combination of these materials. Accessory structure must be clad with materials similar to those used on the main building.
- a. The existing building on the subject property is made of tilt-up concrete walls and glass. Each of the two (2) new MV intake buildings will be made of concrete walls, and the guard shack will be made with concrete and glass. The proposed building materials are compliant with the UDC requirements.
3. Horizontal Articulation: Walls facing a public right-of-way or residentially zoned property shall not extend for a distance greater than four (4) times the wall's height, without having an off set of 10% of the wall's height (maximum of 5 feet); the new plane shall extend for a distance equal to a minimum of 20% of the maximum length of the first plane.
 - a. The guard shack and western MV intake building's western elevations face residentially zoned property and the guard shack's southern elevation faces public right-of-way. Of these three (3) identified façades, none of them include a span where the wall extends for a distance greater than four (4) times the wall's height, therefore, horizontal articulation is not required.
 4. Vertical Articulation: Walls facing a public right-of-way, or a residentially zoned property shall not extend for a distance greater than four (4) times the height of the wall without changing height by a minimum of 10% of the wall's height (maximum 5 feet).
 - a. The guard shack and western MV intake building's western elevations face residentially zoned property and the guard shack's southern elevation faces public right-of-way. Of these three (3) identified façades, none of them include a span where the wall extends for a distance greater than four (4) times the wall's height, therefore, horizontal articulation is not required.
 5. Screening of Rooftop Equipment: All rooftop mounted mechanical, air conditioning, electrical, and satellite dish equipment must not be visible on buildings within the L-P District. Rooftop equipment must be screened from ground and street level view with parapets or other architectural design features constructed of the same materials used on the exterior walls.
 - a. The parapets on the existing building screen existing rooftop mounted equipment. Any new proposed rooftop equipment must be full screened as stated above, and a stipulation has been added to staff's recommendation accordingly.
 6. Color Palette: Buildings in the L-P District are permitted to utilize muted hues, natural and earth tones as the color palette, with use of brighter hues limited to use as an accent color.
 - a. The existing building colors are proposed to remain as they exist today, which include various shades of beige and gray. The proposed MV intake buildings, guard shack, and screen wall will utilize colors that are used on the existing main building, compliant with the UDC requirements.

D. Parking, Loading, Access

1. Parking: Buildings in excess of 100,000 square feet or users with specific parking needs may provide an independent parking study to the City for approval.
 - a. The existing development on the subject property currently includes 316 total parking stalls for passenger vehicles, 11 of which are ADA accessible. With this proposal, the Applicant will reduce the number of parking spaces for passenger vehicles to 153 total parking stalls, with 87 south of the existing building and the remaining 66 stalls north of the existing building.

- b. The Applicant has indicated on the Site Plan that the maximum number of employees per shift will be 30 employees. The proposal includes parking stalls for five (5) times the amount of the maximum employees in one shift, therefore staff finds the proposed amount of parking to be sufficient.
 - c. The UDC requires all parking areas to be paved with concrete or asphalt. The substation area is proposed to be gravel. The applicant provided information documenting the technical safety reasons why substation is designed with gravel. This documentation was reviewed by GBA, the City's Building Code and Plan Review Consultant, and GBA confirmed gravel is both the industry standard for installation at electrical substations and the preferred material from a safety perspective. City staff is supportive in this deviation from the UDC.
2. Maneuvering: The UDC requires that all maneuvering of vehicles shall take place on site or within a mutual access easement.
 - a. A gate is proposed at the northern portion of 196th Street on private property, approximately 38 feet from the public right-of-way, where vehicles and trucks may enter the property. From that gate, drivers would turn right to drive past the guard shack, to another gate, which is approximately 165 feet of travel distance from the first gate. The applicant has indicated that all drivers entering the site will be pre-authorized to enter the site, reducing the wait time to enter the facility and reducing the amount of vehicle or truck queuing on the property and the adjacent 196th Street.
 3. Loading: Per Section 5.2.M.2.f, one (1) loading space is required to be provided adjacent to a public access-way or private service drive, as the building exceeds 10,000 square feet in size.
 - a. An existing loading dock is proposed to remain on the west side of the existing building, meeting this UDC requirement.
 4. Access: The access points that exist on the development today are proposed to remain, with one (1) located at the southwest corner of the property and the other being provided via a cross-access easement to the adjacent property to the east. A private access drive will connect to 191st Street to the north where there is an existing curb cut today. This access drive will provide access to the electric switching yard and electric sub-station from the north. Cross-access will be provided from the existing developed property to the electric switching yard and electric sub-station from the south as well.

E. Landscaping and Fencing

The subject property is adjacent to Johnson County Rural (CTY RUR) zoned property to the west, Edgerton L-P (Logistics Park) zoned property to the north and east, and City public right-of-way for 196th Street to the south. The only changes proposed to the existing landscaping are along the east and western sides of the existing building. The applicant is proposing to remove a total of 50 existing trees and planting 79 new trees and 203 new shrubs. 55 of the new 79 trees are to be evergreens, white pines, and will be planted along the east and west of the new substation that is proposed just north of the existing warehouse. The shrubs are shown to be placed along the west side of the warehouse with 24 deciduous trees to aid in screening the parcel to the west, which is zoned Johnson County Rural (CTY RUR). The northern part of the development is to be screened by the existing vegetation. The landscaping is to be used for screening the development and

must be maintained to ensure proper screening is sustained along each side of the substation. The proposed landscaping plan meets the City's landscape requirements.

The applicant is proposing a 10' tall black fence designed to prevent any kind of damage that can easily be caused by common tools. The fence will help ensure the security of the facility and is proposed to be around the perimeter of the property. The fence is compliant with the City's fencing requirements.

F. Traffic

In the Applicant's Statement of Purpose for this proposal, they indicate that traffic generated once the proposed improvements are completed and the facility is operational, that traffic is anticipated to generate approximately 20 vehicle trips per day, which include employee commuter trips for workforce, occasionally delivery and service vehicles, and periodic equipment replacement deliveries on a multi-year cycle. This facility will not have any public-facing or customer-facing traffic.

G. Stormwater

The applicant has provided a stormwater management study and plan. The City Engineer has reviewed the study and plan. There are comments that the City Engineer has that must be addressed prior to the issuance of a building permit. The City Engineer also noted that the future access road from 191st Street will cross the floodway area. In order to cross the floodway, a bridge will need to be constructed. Specifications of the bridge must be provided for review. A floodplain development permit, which requires a no-rise certification, will be required, as will state and federal permits. The applicant is aware of the required documents and has acknowledged the requirement of having the stormwater study approved by the City Engineer and the required documents.

H. Photometrics

The UDC specifies the allowable footcandles allowed on property lines, as measured five (5) feet above grade, adjacent to residential properties as 0.0. The submitted photometric plan for the existing building meets all of the requirements.

The applicant has also submitted a photometric plan for the electrical substation. The substation photometric plan does not extend to the north or southern property lines; however, there is enough distance and screening between the substation that the readings do not need to extend to those property lines. The readings on the east and west sides exceed the maximum allowed light at the property lines and does not indicate the mounting height of the luminaries. The photometric plan for the substation must meet the UDC requirements prior to certification of the Final Site Plan of the Zoning Administrator and issuance of a building permit.

I. Equipment

The UDC requires all ground or roof mounted equipment to be screened from public view. Public view is defined as view from public right-of-way or adjacent property. The applicant has indicated that there are four (4) areas equipment to be installed, two (2) on the east side and two (2) on the west side. A screen wall comprised of concrete tilt-up walls matching that of the existing building. The equipment must remain screened at all times, and if there are lapses in screening upon inspection, the applicant must correct the screening.

NOTICE OF CITY CODES AND PERMITS

The Applicant is subject to all applicable City codes – whether specifically stated in this report or not – including, but not limited to, Zoning, Buildings and Construction, Subdivisions, and Sign Code. The Applicant is also subject to all applicable local, State, and Federal laws.

Various permits may be required in order to complete this project. Please contact the Building Codes Division of the Community Development Department for more information about City permits. The project may also be subject to obtaining permits and/or approvals from other local, County, State, or Federal agencies.

DOCUMENTS INCLUDED IN PACKET

Sheet #	Title	Date on Document
C0.0	Cover Sheet	05.01.2026
C1.0	Overall Master Site Plan	05.01.2026
C1.1	Enlarged Scale Site Plan (South)	05.01.2026
C1.2	Enlarged Scale Site Plan (North)	05.01.2026
C2.0	Grading Plan (North)	05.01.2026
C2.1	Grading Plan (South)	05.01.2026
C3.0	Storm Sewer Plan & Profiles	05.01.2026
C3.1	Storm Sewer Plan & Profiles	05.01.2026
L.0.0	Existing Landscape Plan	05.01.2026
L1.0	Overall Landscape Plan	05.01.2026
L1.1	Landscape Plan (South)	05.01.2026
L1.2	Landscape Plan (North)	05.01.2026
E-410	Photometric Plan – Overall	
E-411	Photometric Plan – HV Substation	04.16.2026
DD-100.00	Building Plan	04.20.2026
DD-200.00	Building Elevations	04.20.2026
DD-300.00	3D Views	04.20.2026
DD-301.00	3D Views	04.20.2026
FD-01	Ingress/Egress Analysis	05.01.2026
20-21	Statement of Purpose	04.14.2026
22-23	Substation Gravel Response	04.20.2026

STAFF RECOMMENDATION

City Staff recommends approval of Final Site Plan **Application FSP2026-0002** *Final Site Plan for Edgerton Data Center*, subject to the following stipulations:

1. Applicant/Owner Obligation. The site plan, a scale map of proposed buildings, structures, parking areas, easements, roads, and other city requirements (landscaping/berm plan, lighting plan) used in physical development, when approved by the Planning Commission shall create an enforceable obligation to build and develop in accordance with all specifications and notations contained in the site plan instrument. The applicant prior to the issuance of any development permit shall sign all site plans. A Final Site Plan filed for record shall indicate that the applicant shall perform all obligations and requirements contained therein.

2. Prior to the certification of the Final Site Plan by the Zoning Administrator and the issuance of a building permit for exterior site improvements on the subject property, the following must occur:
 - a. A photometric plan for the substation must be submitted and approved by the Zoning Administrator.
 - b. The stormwater management report must be revised by the Applicant and approved by the City Engineer.
 - c. The proper floodplain and floodway permits must be obtained from all applicable jurisdictions and the details for the required bridge must be provided.
3. All outdoor mechanical equipment must be fully screened from public view as defined in the Unified Development Code. If, following construction of the improvements indicated on the Final Site Plan, it is found in the built environment that mechanical equipment is not adequately screened upon inspection by the Zoning Administrator or their designee, the Applicant will be required to adequately screen said equipment.

Note: For Application FSP2026-0002, the Planning Commission is the Approving Authority.

LEGEND:

- AE ACCESS EASEMENT
 - BM BENCHMARK
 - BL or BLA BUILDING LINE
 - DE DRAINAGE EASEMENT
 - EE ELECTRICAL EASEMENT
 - FFE FINISHED FLOOR ELEVATION
 - GE GAS LINE EASEMENT
 - LSE LANDSCAPE EASEMENT
 - MSFE MINIMUM FERTILIZABLE FLOOR ELEVATION
 - PL PROPERTY LINE
 - PLSE PUBLIC EASEMENT
 - ROW or ROW- RIGHT-OF-WAY
 - SE SANITARY SEWER EASEMENT
 - SME STORM MANAGEMENT EASEMENT
 - SW SIDEWALK
 - UE UTILITY EASEMENT
 - WE WATER SURFACE ELEVATION
 - WSE WATERLINE EASEMENT
- ASPHALT PAVEMENT - EXISTING
 - ASPHALT PAVEMENT - PROPOSED
 - CONCRETE PAVEMENT - EXISTING
 - CONCRETE PAVEMENT - PROPOSED
 - CONCRETE SIDEWALK - EXISTING
 - CONCRETE SIDEWALK - PROPOSED
 - CURB & GUTTER
 - CURB & GUTTER-PROPOSED DRY
 - CURB & GUTTER - EXISTING
 - TREELINE
 - EXISTING LOT AND ROW LINES
 - EXISTING PLAT LINES
 - PL PROPERTY LINES
 - ROW RIGHT-OF-WAY
 - ROW SANITARY SEWER MAIN-PROPOSED
 - ROW SANITARY SEWER MAIN - EXIST.
 - ROW STORM SEWER
 - ROW STORM SEWER - EXISTING
 - ROW CABLE TV - EXISTING
 - ROW FIBER OPTIC CABLE - EXISTING
 - ROW TELEPHONE LINE - EXIST.
 - ROW ELECTRIC LINE - EXISTING
 - ROW OVERHEAD POWER LINE - EXIST.
 - ROW UNDERGROUND ELECTRIC - EX.
 - ROW GAS LINE - EXISTING
 - ROW WATERLINE - EXISTING
 - ROW LIGHT - EXISTING
 - ROW EXISTING MANHOLE
 - ROW CLEANOUT
 - ROW EXISTING SANITARY MANHOLE
 - ROW PROPOSED SANITARY MANHOLE
 - ROW EXISTING AREA INLET
 - ROW EXISTING CURB INLET
 - ROW EXISTING GROUND INLET
 - ROW EXISTING JUNCTION BOX
 - ROW EXISTING ELECTRICAL EQUIP.
 - ROW EXISTING STORM MANHOLE

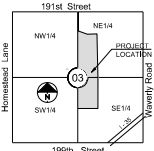

SECTION C0-114-R23
LOCATION MAP
SCALE 1" = 200'

UTILITY CONTACTS:

- City of Edgerton**
404 E. Nelson
P.O. Box 256
Edgerton, Kansas
913.852.9211
Edgertonks.org
- EVERDRI**
1625 WEST 10TH STREET
LENEXA, KS 66219
(913) 894-3310
Everdry.com
- Century Link (Cable)**
800.786.9595
lscs.centurylink.com
- KANSAS GAS SERVICE**
401 N. Lynwood
1440 W. 88th Street
Overland Park, Kansas 66213
(913) 344-8800
kansaskasgas.com
- Johnson County Rural Water District #7**
535 W. Main Street
Gardner, Kansas
(913) 856-2378
water7.com
- Century Link (Phone)**
800.786.9595
lscs.centurylink.com

Kansas One Call
811
www.kansasonecall.com

CITY OF EDGERTON NOTES:

1. THE EDGERTON DESIGN AND CONSTRUCTION MANUAL SHALL GOVERN THE CONSTRUCTION OF ALL PUBLIC IMPROVEMENTS FOR THIS PROJECT.
2. THE CITY OF EDGERTON'S PLAN REVIEW IS ONLY FOR GENERAL CONFORMANCE WITH THE EDGERTON MUNICIPAL CODE AND THE DESIGN AND CONSTRUCTION MANUAL. THE APPROVAL OF THESE IMPROVEMENT PLANS SHALL NOT BE CONSTRUED TO BE AN APPROVAL OF ANY VIOLATION OF THE CITY OF EDGERTON'S MUNICIPAL CODE AND LOCAL BUILDING AND ZONING ORDINANCES. THE CITY OF EDGERTON IS RESPONSIBLE FOR THE ACCURACY AND ADEQUACY OF THE DESIGN, OR DIMENSIONS AND ELEVATIONS, WHICH SHALL BE CONFIRMED AND CORRELATED AT THE PROJECT SITE. THE CITY OF EDGERTON THROUGH ITS APPROVAL OF THESE IMPROVEMENT PLANS ASSUMES NO RESPONSIBILITY OTHER THAN AS STATED ABOVE FOR ACCURACY AND COMPLETENESS.
3. THESE IMPROVEMENT PLANS ARE APPROVED INITIALLY FOR ONE (1) YEAR AFTER WHICH THEY ARE AUTOMATICALLY VOID AND MUST BE UPDATED AND RE-APPROVED BY THE CITY ENGINEER BEFORE ANY CONSTRUCTION WILL BE PERMITTED.
4. ALL EXISTING UTILITIES SHOWN ON THESE IMPROVEMENT PLANS ARE ACCORDING TO THE BEST INFORMATION AVAILABLE TO THE DESIGN ENGINEER. HOWEVER, ALL UTILITIES ACTUALLY EXISTING MAY NOT BE SHOWN. UTILITIES DAMAGED THROUGH THE NEGLIGENCE OF THE CONTRACTOR TO OBTAIN THE LOCATION OF SAME SHALL BE REPAIRED OR REPLACED AT THE EXPENSE OF THE CONTRACTOR.
5. ALL EXISTING DRIVEWAYS, PARKING LOTS, SIDEWALKS, FENCES AND UNDERGROUND SPRINKLER SYSTEMS DAMAGED THROUGH THE NEGLIGENCE OF THE CONTRACTOR DURING CONSTRUCTION SHALL BE RESTORED TO THEIR ORIGINAL OPERATING CONDITION AT THE EXPENSE OF THE CONTRACTOR. ALL AFFECTED SURFACES, FENCES, PIPES AND FITTINGS SHALL BE REPLACED WITH NEW MATERIALS AT THE ORIGINAL LOCATION. ALL RESTORATION WORK SHALL BE ACCEPTABLE TO THE CITY ENGINEER AND THE PROPERTY OWNER.
6. CONTRACTOR SHALL BE RESPONSIBLE FOR ALL COST AND COORDINATION WITH ELECTRICAL COMPANY TO SUPPLY POWER HOORUP TO CONTROLLER. THE SHALL INCLUDE ANY CONDUIT, WIRING, METER, AND OTHER REQUIREMENTS BY THE ELECTRICAL UTILITY COMPANY.
7. WHEN RELOCATION OF STREET LIGHT POLES, JUNCTION BOXES, AND CONTROLLERS TO AVOID CONFLICTS WITH EXISTING UTILITIES AND FEATURES MAY BE ALLOWED UPON APPROVAL OF THE ENGINEER.

UTILITIES:

1. EXISTING UTILITIES HAVE BEEN SHOWN TO THE GREATEST EXTENT POSSIBLE BASED UPON INFORMATION PROVIDED TO THE ENGINEER. THE CONTRACTOR IS RESPONSIBLE FOR CONTRACTING THE RESPECTIVE UTILITY COMPANIES AND FIELD LOCATING UTILITIES PRIOR TO CONSTRUCTION AND IDENTIFYING ANY POTENTIAL CONFLICTS. ALL CONFLICTS SHALL IMMEDIATELY BE BROUGHT TO THE ATTENTION OF THE ENGINEER.
2. THE CONTRACTOR SHALL BE RESPONSIBLE FOR COORDINATING ANY REQUIRED UTILITY RELOCATIONS. UTILITIES DAMAGED THROUGH THE NEGLIGENCE OF THE CONTRACTOR SHALL BE REPAIRED AT THE CONTRACTOR'S EXPENSE.
3. CONTRACTOR SHALL VERIFY FLOW LINES AND STRUCTURE TOPS PRIOR TO CONSTRUCTION, AND SHALL NOTIFY ENGINEER OF ANY DISCREPANCIES. PROVIDE SHOP DRAWINGS FOR ALL PRECAST AND MANUFACTURED UTILITY STRUCTURES FOR REVIEW BY THE ENGINEER PRIOR TO CONSTRUCTION OF THE STRUCTURES.
4. UTILITY SEPARATION: WATERLINES SHALL HAVE A MINIMUM OF 10 FEET HORIZONTAL AND 2 FEET VERTICAL SEPARATION FROM ALL SANITARY SEWER LINES, MANHOLES, AND SANITARY SEWER SERVICE LATERALS. AS MEASURED FROM EDGE TO EDGE. IF MINIMUM SEPARATIONS CANNOT BE OBTAINED, CONCRETE ENCASUREMENT OF THE SANITARY LINE SHALL BE REQUIRED 10 FEET IN EACH DIRECTION OF THE CONFLICT. PAYMENT FOR TRENCHING, BACKFILLING, PIPE EMBEDMENT, FLOWABLE FILL, BACKFILL MATERIALS, CLEAN UP, SEEDING, SOILING AND ANY OTHER ITEMS NECESSARY FOR THE CONSTRUCTION OF THE UTILITY LINE SHALL BE INCLUDED IN THE CONTRACT PRICE FOR THE UTILITY INSTALLATION.
5. THE CONTRACTOR SHALL BE RESPONSIBLE FOR CONTRACTING RESPECTIVE UTILITY COMPANIES AHEAD OF IN ADVANCE FOR THE RESECTION OF ANY PROPOSED UTILITY MAIN EXTENSION OR SERVICE LINE OR SERVICE CONNECTION TO ANY EXISTING MAIN.
6. TRENCH POLES SHALL BE NEATLY PLACED ON SITE ADJACENT TO THE TRENCH, AND COMPACTED TO PREVENT SINKING AND EXCESS SEDIMENT RUNOFF. UNSUITABLE MATERIALS, EXCESS ROCK AND SHALE, ASPHALT, CONCRETE, TREES, BRUSH, ETC. SHALL BE PROPERLY DEPOSITED OFF SITE. MATERIALS MAY BE WASTED ON SITE AT THE DIRECTION OF THE OWNER OR HIS APPOINTED REPRESENTATIVE.
8. ALL EXCAVATION BE CONSIDERED UNCLASSIFIED, UNLESS NOTED OTHERWISE. UNCLASSIFIED EXCAVATION FOR UTILITY TRENCHING IS SUBSIDIARY TO THE UNIT PRICE PROVIDED FOR THE PIPE ANY QUANTITY PROVIDED FOR ROCK EXCAVATION IS ESTIMATED BASED ON THE BEST INFORMATION PROVIDED TO THE PROJECT ENGINEER. THE ENGINEER HAS THE AUTHORITY TO IDENTIFY AND DEFINE THE PHYSICAL CHARACTERISTICS TO DETERMINE THE CLASSIFICATION. UNIT PRICE QUANTITIES FOR ROCK EXCAVATION WILL BE PAID AT A TRENCH WIDTH OF THE NOMINAL PIPE DIAMETER OF THE INSTALLED MAIN PLUS 18 INCHES. CONTRACTOR IS REQUIRED TO DISPOSE OF EXCESS ROCK FROM THEIR TRENCHING DISPOSING IT IN AREAS AS SPECIFIED BY THE PROJECT ENGINEER.

EDGERTON PROJECT - REVISED DEVELOPMENT PLAN

CITY OF EDGERTON JOHNSON COUNTY, KANSAS

GENERAL NOTES:

1. ANY PUBLIC SANITARY SEWERS, ASSOCIATED WITH THIS PROJECT SHALL BE OBSERVED BY THE CITY OF EDGERTON OR ITS REPRESENTATIVES.
2. CONTRACTOR IS RESPONSIBLE FOR VERIFYING QUANTITIES PRIOR TO BIDDING, AS WELL AS BECOMING FAMILIAR WITH AND SATISFYING HIMSELF AS TO THE GENERAL, LOCAL AND SITE CONDITIONS THAT MAY AFFECT COST, PROGRESS, AND PERFORMANCE OF WORK.
3. CONTRACTOR SHALL THOROUGHLY REVIEW ENGINEER WRITTEN NOTICE OF ALL CONFLICTS, ERRORS, OMISSIONS OR DISCREPANCIES THAT THE CONTRACTOR DISCOVERS IN THE BIDDING DOCUMENTS AND CONFIRM THAT THE WRITTEN RESOLUTION THEREBY BY THE ENGINEER IS ACCEPTABLE TO CONTRACTOR. CONTRACTOR IS RESPONSIBLE FOR THE JOB SITE SAFETY OF THE PROJECT AND THE SAFETY OF THE PUBLIC AND SHALL ADHERE TO ALL FEDERAL, STATE AND LOCAL SAFETY REGULATIONS.
4. CONTRACTOR SHALL BE RESPONSIBLE FOR COORDINATING ALL CONSTRUCTION ACTIVITIES WITH OTHER CONTRACTORS CONCURRENTLY WORKING ON SITE. CONTRACTOR SHALL COORDINATE ALL SUBCONTRACTOR ACTIVITIES AND SHALL BE THE SINGLE CONTACT FOR THE OWNERS.
5. CONTRACTOR SHALL SECURE ALL REQUIRED PERMITS INSURANCE REQUIREMENTS AND BONDING PRIOR TO CONSTRUCTION. INSURANCE CERTIFICATES SHALL NAME OWNER AND ENGINEER AS ADDITIONAL INSURED. WATER FOR USE ON SITE MUST BE PURCHASED FROM THE LOCAL WATER UTILITY HAVING JURISDICTION.
6. ALL TRAFFIC CONTROL REQUIREMENTS IN CONJUNCTION WITH THE PROPOSED CONSTRUCTION SHALL BE IN CONFORMANCE WITH THE MANUAL OF UNIFORM TRAFFIC CONTROL DEVICES (MUTCD) AND SHALL BE A SUBSIDIARY OBLIGATION OF THE CONTRACT.
7. CONTRACTOR IS RESPONSIBLE FOR THE COORDINATION OF ALL MATERIAL TESTING REQUIRED FOR THEIR WORK. THIS INCLUDES SCHEDULING OF TESTS, COORDINATING AND PROVIDING ACCESS TO SAMPLE LOCATIONS, AND SATISFYING ALL TEST RESULT REPORTING REQUIREMENTS.
8. CONSTRUCTION OR IMPROVEMENTS SHOWN COMPLETED BY THIS SET OF DRAWINGS SHALL NOT BE INITIATED OR ANY PART THERE OF UNDERTAKEN UNTIL THE ENGINEER IS NOTIFIED OF SUCH INTENT AND ALL REQUIRED AND PRELIMINARY SOLICITED SERVICES ARE RECEIVED AND APPROVED.

EARTHWORK:

1. It is recommended that a Geotechnical Engineer observe and document all earthwork activities.
2. Contours have been shown at 2-foot or 3-foot intervals, as indicated. Grading shall consist of completing the earthwork required to bring the physical ground elevations of the existing site to the finished grade (or sub-grade) elevations provided on the plans as spot grades, contours or other means as indicated on the plans.
3. The existing site topography depicted on the plans by contours has been established by aerial photography and field verified by spot observations. The contour elevations provided may not be exact ground elevations, but rather interpretations of such. Accuracy shall be considered to be such that not more than 10 percent of spot elevation checks shall be in error by more than one-tenth of one foot, as defined by the National Map Accuracy Standards. Any quantities provided for earthwork volumes are established using this topography contour accuracy, and therefore the inherent accuracy of any earthwork quantity is assumed from the topography accuracy.
4. Proposed contours are to approximate finished grade.
5. Unless otherwise noted, payment for earthwork shall include building of the curb and gutter, sidewalk and further manipulation of utility trench spoils. The site shall be left in a suitable condition and positive drainage maintained throughout.
6. Unless otherwise noted, all earthwork is considered Unclassified. No additional compensation will be provided for rock or shale excavation, unless specifically noted otherwise.
7. Prior to earthwork activities, pre-erosion control and sediment control devices shall be in place per the Storm Water Pollution Prevention Plan and/or the Erosion and Sediment Control Plan prepared for this site.
8. All exposed knifed or exposed from all areas to be graded and stockpiled adjacent to the site at an area specified by the project owner or his appointed representative. Vegetation, trees, trees, brush, tree roots and limbs, rock fragments greater than boulders and other obstructions shall be removed and properly disposed off site or as directed by the owner or his appointed representative.
9. Unless otherwise specified in the Geotechnical Report, all fills shall be placed in maximum 6-inch lifts and compacted to 95-percent of maximum density as defined using a standard proctor test (ASTM D 1557/1585M 098).
10. Subgrade for pavements shall be provided prior to paving operations utilizing a fully tested borrow area dump truck. All areas exhibiting excessive pumping and heaving shall be removed, filled and compacted with suitable materials and retested until acceptable results are achieved and field approval has been obtained from the Geotechnical Engineer.
11. Subgrade for building pad shall include a minimum of 18 inches of Low Volume Charge (LVC) material or as identified in the site specific Geotechnical Report.
12. If fill materials shall be per Geotechnical Report and shall not include organic matter, debris or topsoil. All fills placed on slopes greater than 1:1 shall be benched.
13. The Contractor shall be responsible for distributing the topsoil over proposed turf and landscaped areas to a minimum depth of 4 inches below final grade.
14. All areas shall be prepared for positive drainage. Unless noted otherwise the following grades shall apply:
a. Turf Areas - 2.0% Minimum, 4:1 V Maximum
b. Paved Areas - 1.5% Minimum, 2% Maximum
15. A.D.A. parking stalls will be sloped greater than 2% in any direction and constructed per A.D.A. requirements.
16. All graded areas shall be seeded, seeded and mulched immediately after earthwork activities have ceased. Seeding shall be per the Erosion and Sediment Control Plan and/or Landscape Plan. If not specified seeding shall be per APWA Section 200.0, latest edition. Unless otherwise noted, seeding shall be subsidiary to the contract price for earthwork and grading activities.
17. Undersprays are recommended for all paved areas adjacent to irrigated turf and landscaped beds.
18. Contractor shall adhere to the reporting requirements outlined in the Storm Water Pollution Prevention Plan (SWPPP) prepared for this project. Erosion and Sediment Control devices shall be properly maintained and kept clean of all soil and debris and in good working order. Additional erosion and sediment control measures shall be installed as required.

Sheet Number	Sheet Title	Sheet Title
C0.0	COVER SHEET	
C1.0	OVERALL MASTER SITE PLAN	
C1.1	ENLARGED SCALE SITE PLAN (SOUTH)	
C1.2	ENLARGED SCALE SITE PLAN (NORTH)	
C2.0	GRADING PLAN (NORTH)	
C2.1	GRADING PLAN (SOUTH)	
C3.0	STORM SEWER PLAN & PROFILES	
C3.1	STORM SEWER PLAN & PROFILES	
L.0.0	EXISTING LANDSCAPE PLAN	
L1.0	OVERALL LANDSCAPE PLAN	
L1.1	LANDSCAPE PLAN (SOUTH)	
L1.2	LANDSCAPE PLAN (NORTH)	
E.0.0	PHOTOMETRIC PLAN - OVERALL	
E.0.1	PHOTOMETRIC PLAN - RV SUBSTATION	
DD-100.00	BUILDING PLAN	
DD-200.00	BUILDING ELEVATIONS	
DD-300.00	3D VIEWS	
DD-400.00	3D VIEWS	
FD.0.1	INTEGRATED ANALYSIS	

CONSULTANT CONTACTS:

- City Engineering/Planning**
Schlagel and Associates
14820 W. 107th Street
Lenexa, Kansas 66215
(913) 492-5158
Jeffrey T. Dickinson, P.E.
- Landscaping/Architect**
Schlagel and Associates
14820 W. 107th Street
Lenexa, Kansas 66215
(913) 492-5158
Daniela Fischer, L.A.
- Surveyor**
Anderson Survey Company
1271 N.J. Dale Schaeffert
Locks Summit, Missouri 64064
(816) 248-0050
Robert L. Anderson, P.L.S.
- ENGINEER**
Robert Director, Mission Critical
18 W. 49th Street
New York, New York 10022
(212) 756-7272
Robert Zurek, P.E.
- Owner/Developer**
Dames Digital Solutions Kansas, LLC
317 7th Street
Miami Beach, Florida 33134
(954) 534-1888
David Varghese, V.P., Development

CERTIFICATION:

RECEIVED and placed on record this _____ day of _____, 2026 by

(Zoning Administrator)

APPROVED by the Edgerton Planning Commission this _____ day of _____, 2026 by

(Chair of Planning Commission)

I certify that I have reviewed this SITE PLAN and will comply with all specifications, changes, and amendments herein, and that this instrument creates a legally enforceable obligation to build and develop in accordance with all final agreements.

Applicant signature: _____ Date: _____

JOHNSON COUNTY BENCHMARK:

JCVCM BM181
Beneate Alam, Disk - Stamp: BM181, Located on center west end of the North Heasall RCB - From intersection of Newby Road & 191st Street - West 1/4, 10/16/25 to RCB, Elev. = 1010.97



AERIAL MAP



PREPARED BY: SCHLAGEL AND ASSOCIATES, P.A.

EDGERTON PROJECT - REVISED DEVELOPMENT PLAN

31800 W. 196TH STREET EDGERTON, KANSAS

NO.	DATE	DESCRIPTION
1	10/16/25	ISSUED FOR PERMIT
2	10/16/25	ISSUED FOR PERMIT
3	10/16/25	ISSUED FOR PERMIT
4	10/16/25	ISSUED FOR PERMIT
5	10/16/25	ISSUED FOR PERMIT
6	10/16/25	ISSUED FOR PERMIT
7	10/16/25	ISSUED FOR PERMIT
8	10/16/25	ISSUED FOR PERMIT
9	10/16/25	ISSUED FOR PERMIT
10	10/16/25	ISSUED FOR PERMIT

COVER SHEET

C0.0

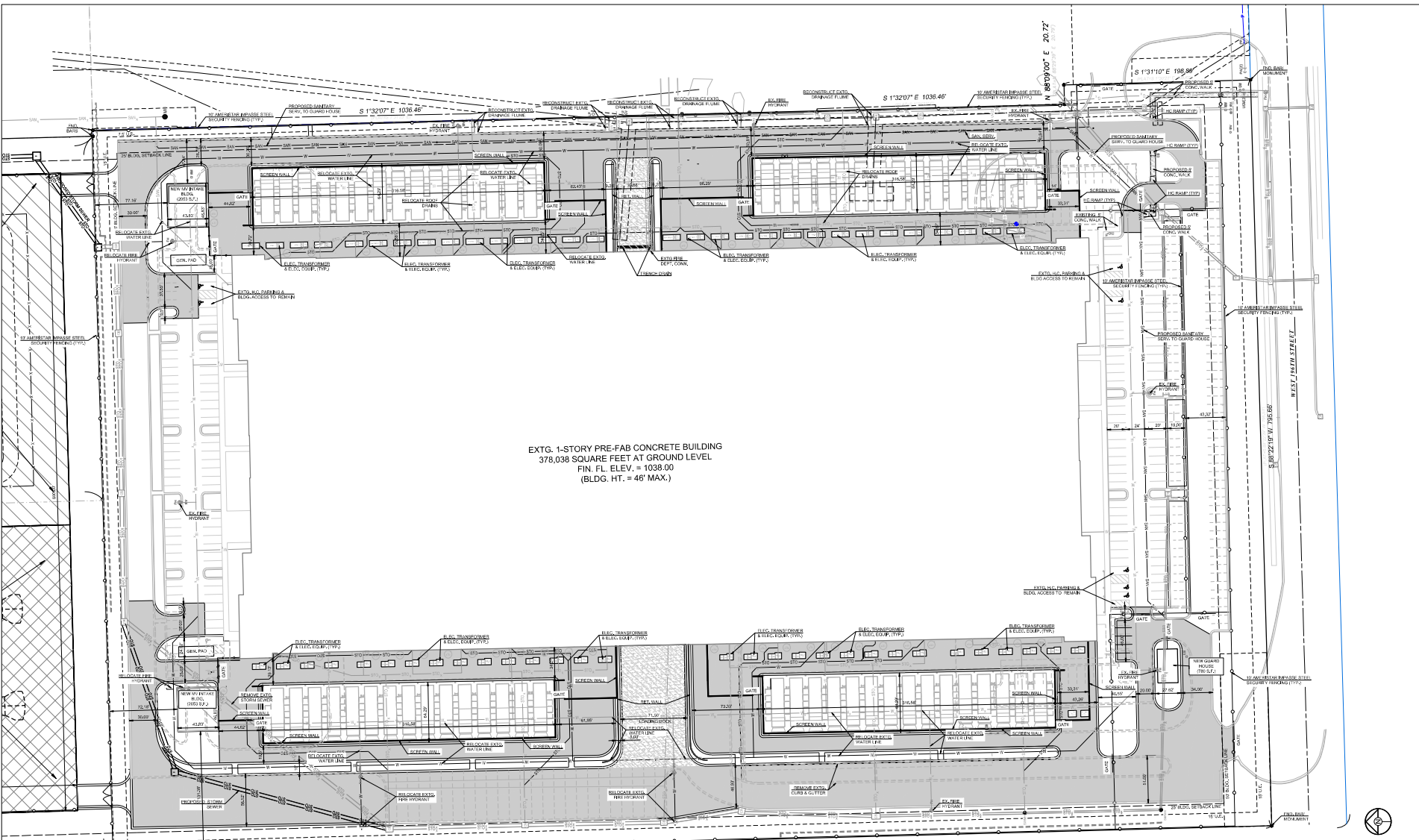

EXTG. 1-STORY PRE-FAB CONCRETE BUILDING
378,038 SQUARE FEET AT GROUND LEVEL
FIN. FL. ELEV. = 1038.00
(BLDG. HT. = 48' MAX.)

Site Information:
Property Address: 31800 West 196th Street, Edgerton, Kansas 66211
Existing Building Floor Area: 378,038 Square Feet
Existing Floor Area Ratio: 0.18
Proposed Building Floor Area: 382,524 Square Feet
Proposed Floor Area Ratio: 0.19
Current Zoning: L-4 (Logistics Park)
Proposed Zoning: L-4P (Logistics Park) - No Change
Current Use: Office/Warehouse Distribution
Proposed Use: Data Center
Net Site Area: 2,343,242 Square Feet (53,79 Acres)

Parking Provisions:
Max Number of employees per shift = 30
Parking Required (3.0 x 1.2) = 45 Stalls
Parking Provided: 1152 Stalls

SUMMARY OF EXISTING CONDITIONS		SUMMARY - PROJECT COMPLETION	
	AREA (S.F.)		AREA (S.F.)
TOTAL BUILDINGS	378,038	TOTAL BUILDINGS	382,524
TOTAL PAVEMENT	386,038	TOTAL PAVEMENT	740,961
TOTAL IMPERVIOUS*	764,074	TOTAL IMPERVIOUS*	1,123,825
TOTAL PERMEABLE	1,579,168	TOTAL PERMEABLE	1,076,817
TOTAL PROPERTY AREA	2,343,242	TOTAL PROPERTY AREA	2,343,242

* IMPERVIOUS AREA INCLUDES 923,000 SQ. FT. OF GRAVEL SURFACE AREA

LOT AREA:	EXISTING	PROPOSED
BUILDING AREA	378,038 S.F. (16.24%)	382,524 S.F. (16.31%)
PAVEMENT/PAVED AREA	386,038 S.F. (16.47%)	471,961 S.F. (20.13%)
GRAVEL PAD AREA	408 S.F. (0.02%)	323,000 S.F. (13.78%)
OPENLANDSCAPE AREA	1,971,496 S.F. (87.29%)	1,219,417 S.F. (52.24%)
PROPOSED USE:	DATA CENTER	
# OF EMPLOYEES: (30 MAX, SHIFT 1 TO 4 OPERATIONS)	PARKING REQUIRED: 45	

- SITE LEGEND:**
- 4" CONCRETE SIDEWALK
 - CONCRETE DRIVE
 - ASPHALT DRIVE
 - TYPE B CURB & GUTTER
 - TYPE B CURB & GUTTER - DRY
 - 24" WIDE CONC. REBON CURB
 - EXISTING CURB & GUTTER
 - 10' AMMETER IMPASSIBLE STEEL SECURITY FENCE
 - 10' BLACK VINYL-COATED CHAIN LINK FENCE

Legal Description:
Lot 1, Logistics Park Kansas City Phase IV, Second (B), a Subdivision in the City of Edgerton, Johnson County, Kansas, being more particularly described as follows:
All that part of the northeast 1/4 of section 3, township 15 south, range 22 east, in the city of Edgerton, Johnson County, Kansas, being more particularly described as follows:
Beginning at a point 360.00 feet east of the southwest corner of the west of Section 3, Township 15 south, Range 22 east, City of Edgerton, Johnson County, Kansas, said point being on the south line of said quarter section; thence south 123.00 feet and parallel to the west line of said quarter section; thence east 382.52 feet and parallel to the north line of said quarter section; thence south 1732.00 feet and parallel to the west line of said quarter section; thence north 1732.00 feet and parallel to the east line of said quarter section; thence north 375.00 feet and parallel to the west line of said quarter section; thence west 382.52 feet and parallel to the north line of said quarter section; thence south 382.52 feet and parallel to the west line of said quarter section; thence east 382.52 feet and parallel to the north line of said quarter section to the point of beginning, all being in the 42' wide zone of Section 3, Township 15 south, Range 22 east, Johnson County, Kansas, comprising 15.45 acres, more or less.
And also
Beginning at the northeast corner of the west of Section 3, Township 15, Range 22 east, City of Edgerton, Johnson County, Kansas; thence south 302.00 feet and along the west line of said quarter section to the southwest corner of said quarter section; thence east 382.52 feet and along the south line of said quarter section; thence north 1732.00 feet and parallel to the west line of said quarter section; thence north 375.00 feet and parallel to the west line of said quarter section to a point on the north line of said quarter section; thence west 382.52 feet and parallel to the north line of said quarter section to the point of beginning, all being in the 42' wide zone of Section 3, Township 15, Range 22 east, Johnson County, Kansas, comprising 15.45 acres, more or less.
Except any part used or dedicated for streets, roads or public rights of ways.

SCHLAGEL
14823 West 107th Street, Lenexa, Kansas 66215
(913) 665-1100 • Fax: (913) 665-8800
www.schlagel.com • schlagel@schlagel.com
National Office, Overland Park, Kansas
©2016, All Rights Reserved

PREPARED BY:
SCHLAGEL & ASSOCIATES, P.A.

EDGERTON PROJECT - REVISED DEVELOPMENT PLAN
31800 W. 196TH STREET EDGERTON, KANSAS

ENLARGED SCALE SITE PLAN (SOUTH)
C1.1

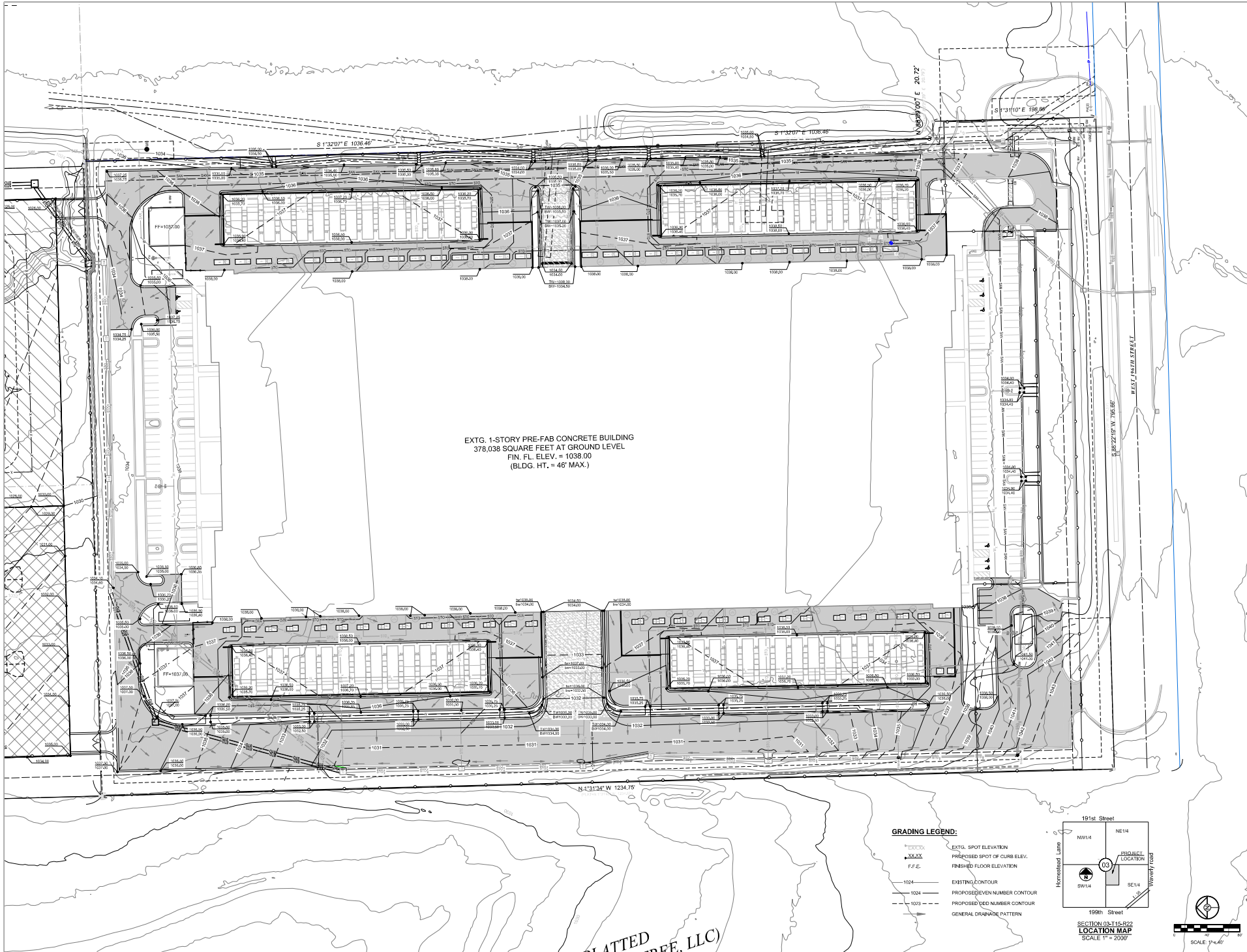

EXTG. 1-STORY PRE-FAB CONCRETE BUILDING
 378,038 SQUARE FEET AT GROUND LEVEL
 FIN. FL. ELEV. = 1038.00
 (BLDG. HT. = 46' MAX.)

GRADING LEGEND:

- EXTG. SPOT ELEVATION
- PROPOSED SPOT OF CURB ELEV.
- F.F.E. FINISHED FLOOR ELEVATION
- EXISTING CONTOUR
- PROPOSED EVEN NUMBER CONTOUR
- PROPOSED ODD NUMBER CONTOUR
- GENERAL DRAINAGE PATTERN

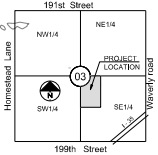

SECTION 03-T15-R22
 LOCATION MAP
 SCALE 1" = 200'



PREPARED BY:



SCHLAGEL & ASSOCIATES, P.A.

EDGERTON PROJECT - REVISED DEVELOPMENT PLAN

31800 W. 196TH STREET EDGERTON, KANSAS

NO.	DESCRIPTION
1	PROPOSED GRADING
2	EXISTING GRADING
3	PROPOSED CURB ELEVATION
4	FINISHED FLOOR ELEVATION
5	EXISTING CONTOUR
6	PROPOSED EVEN NUMBER CONTOUR
7	PROPOSED ODD NUMBER CONTOUR
8	GENERAL DRAINAGE PATTERN

GRADING PLAN (SOUTH)

C2.1

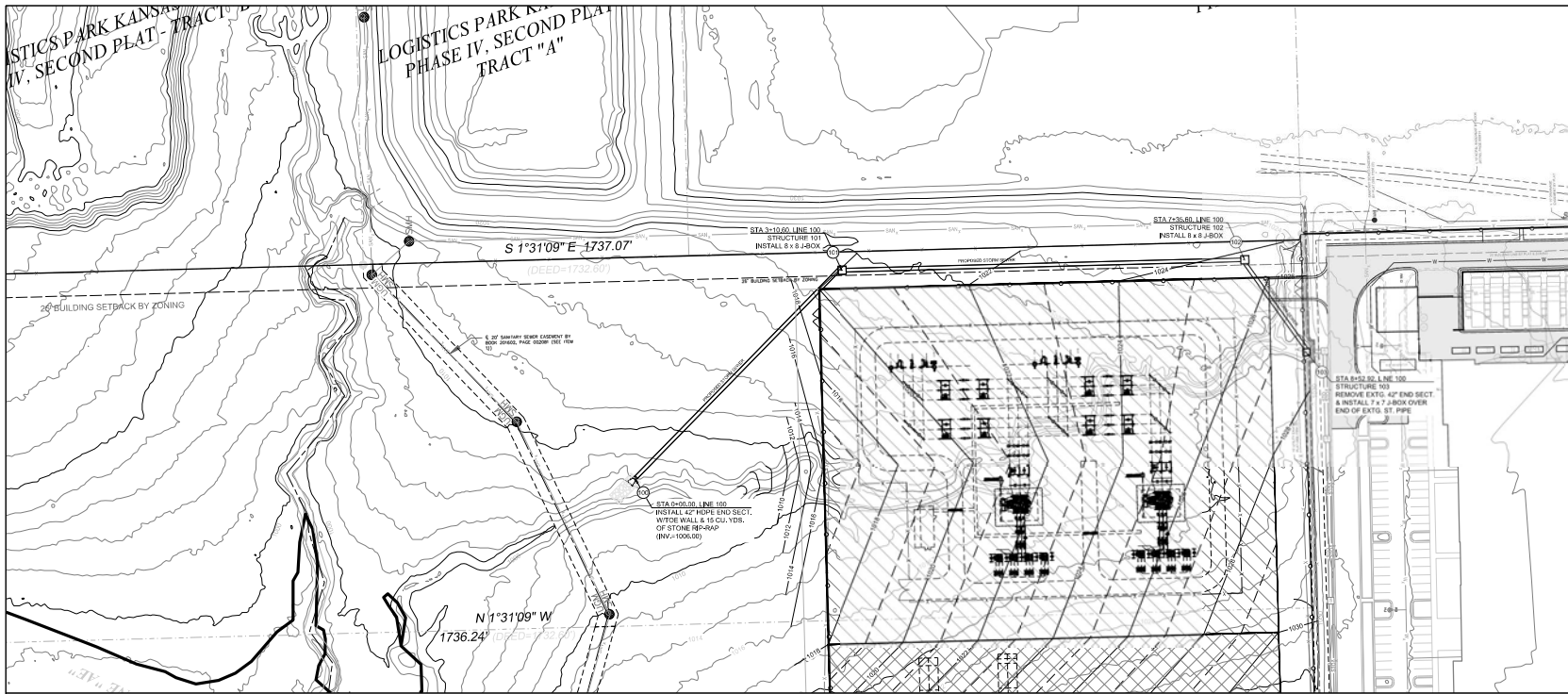

GRADING LEGEND:

XXXXXX	EXTG. SPOT ELEVATION
XXXX	PROPOSED SPOT OF CURB ELEV.
F.F.E.	FINISHED FLOOR ELEVATION
-----	EXISTING CONTOUR
-----	PROPOSED CONTOUR

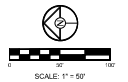

SCHLAGEL & ASSOCIATES, P.A.

EDGERTON PROJECT - REVISED DEVELOPMENT PLAN

31800 W. 196TH STREET EDGERTON, KANSAS

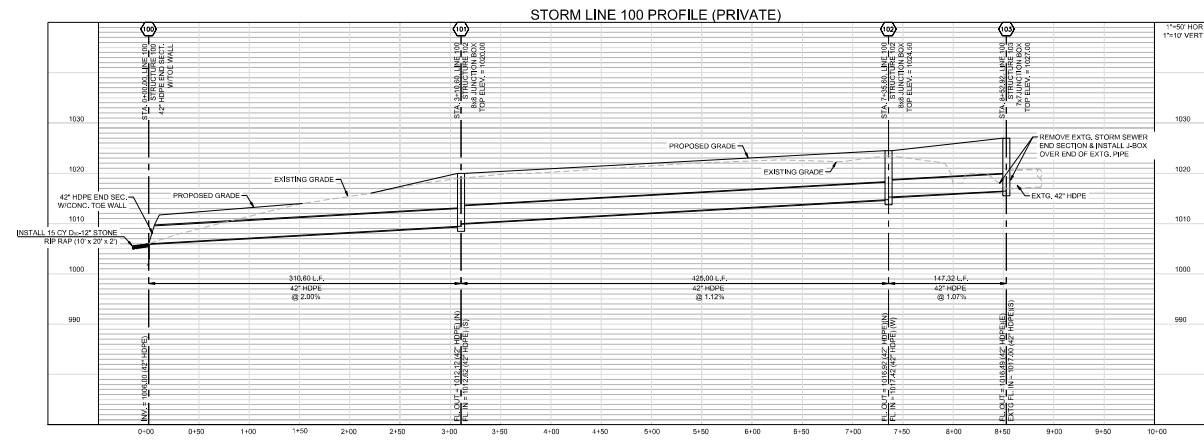

NO.	DATE	DESCRIPTION

STORM SEWER PLAN & PROFILES

C3.0

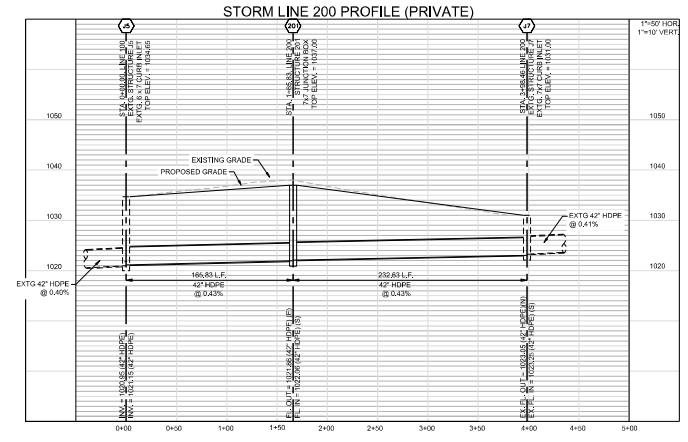
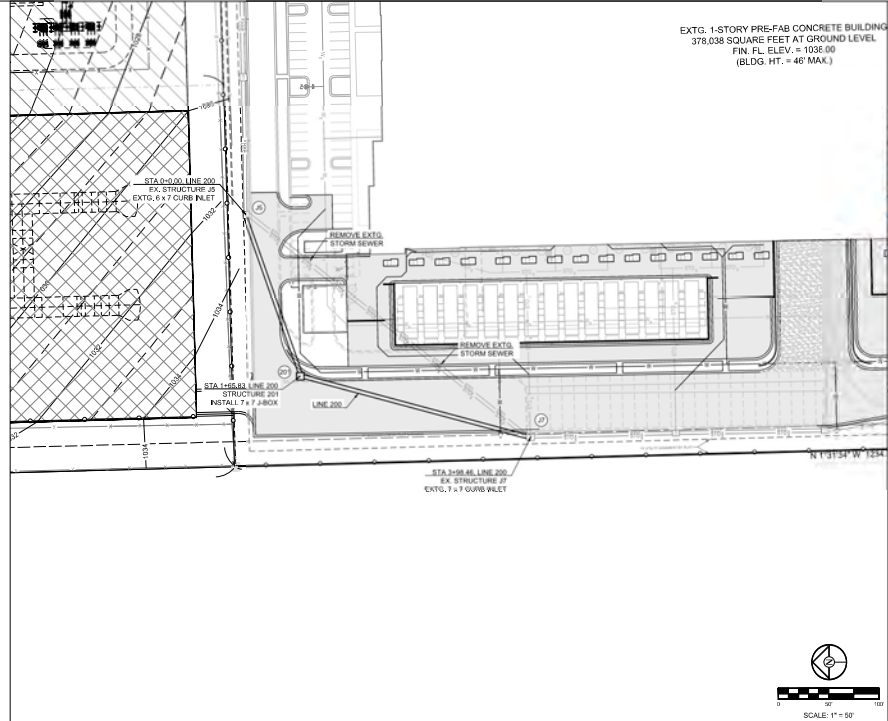

SCHLAGEL
ENGINEERS ARCHITECTS
1815 N. 10th St., Suite 100, Edgerton, KS 66524
TEL: 785-241-1111 FAX: 785-241-1112
WWW.SCHLAGEL-PA.COM

PREPARED BY:
SCOTT E. BRIDGES
REGISTERED PROFESSIONAL ENGINEER
18516
KANSAS

SCHLAGEL ASSOCIATES, P.A.

EDGERTON PROJECT - REVISED DEVELOPMENT PLAN

31800 W. 196TH STREET EDGERTON, KANSAS

NO.	DATE	DESCRIPTION
1	08/14/2018	ISSUED FOR PERMITS
2	08/14/2018	ISSUED FOR PERMITS
3	08/14/2018	ISSUED FOR PERMITS
4	08/14/2018	ISSUED FOR PERMITS
5	08/14/2018	ISSUED FOR PERMITS
6	08/14/2018	ISSUED FOR PERMITS
7	08/14/2018	ISSUED FOR PERMITS
8	08/14/2018	ISSUED FOR PERMITS
9	08/14/2018	ISSUED FOR PERMITS
10	08/14/2018	ISSUED FOR PERMITS
11	08/14/2018	ISSUED FOR PERMITS
12	08/14/2018	ISSUED FOR PERMITS
13	08/14/2018	ISSUED FOR PERMITS
14	08/14/2018	ISSUED FOR PERMITS
15	08/14/2018	ISSUED FOR PERMITS
16	08/14/2018	ISSUED FOR PERMITS
17	08/14/2018	ISSUED FOR PERMITS
18	08/14/2018	ISSUED FOR PERMITS
19	08/14/2018	ISSUED FOR PERMITS
20	08/14/2018	ISSUED FOR PERMITS
21	08/14/2018	ISSUED FOR PERMITS
22	08/14/2018	ISSUED FOR PERMITS
23	08/14/2018	ISSUED FOR PERMITS
24	08/14/2018	ISSUED FOR PERMITS
25	08/14/2018	ISSUED FOR PERMITS
26	08/14/2018	ISSUED FOR PERMITS
27	08/14/2018	ISSUED FOR PERMITS
28	08/14/2018	ISSUED FOR PERMITS
29	08/14/2018	ISSUED FOR PERMITS
30	08/14/2018	ISSUED FOR PERMITS
31	08/14/2018	ISSUED FOR PERMITS
32	08/14/2018	ISSUED FOR PERMITS
33	08/14/2018	ISSUED FOR PERMITS
34	08/14/2018	ISSUED FOR PERMITS
35	08/14/2018	ISSUED FOR PERMITS
36	08/14/2018	ISSUED FOR PERMITS
37	08/14/2018	ISSUED FOR PERMITS
38	08/14/2018	ISSUED FOR PERMITS
39	08/14/2018	ISSUED FOR PERMITS
40	08/14/2018	ISSUED FOR PERMITS
41	08/14/2018	ISSUED FOR PERMITS
42	08/14/2018	ISSUED FOR PERMITS
43	08/14/2018	ISSUED FOR PERMITS
44	08/14/2018	ISSUED FOR PERMITS
45	08/14/2018	ISSUED FOR PERMITS
46	08/14/2018	ISSUED FOR PERMITS
47	08/14/2018	ISSUED FOR PERMITS
48	08/14/2018	ISSUED FOR PERMITS
49	08/14/2018	ISSUED FOR PERMITS
50	08/14/2018	ISSUED FOR PERMITS

STORM SEWER PLAN & PROFILES

C3.1

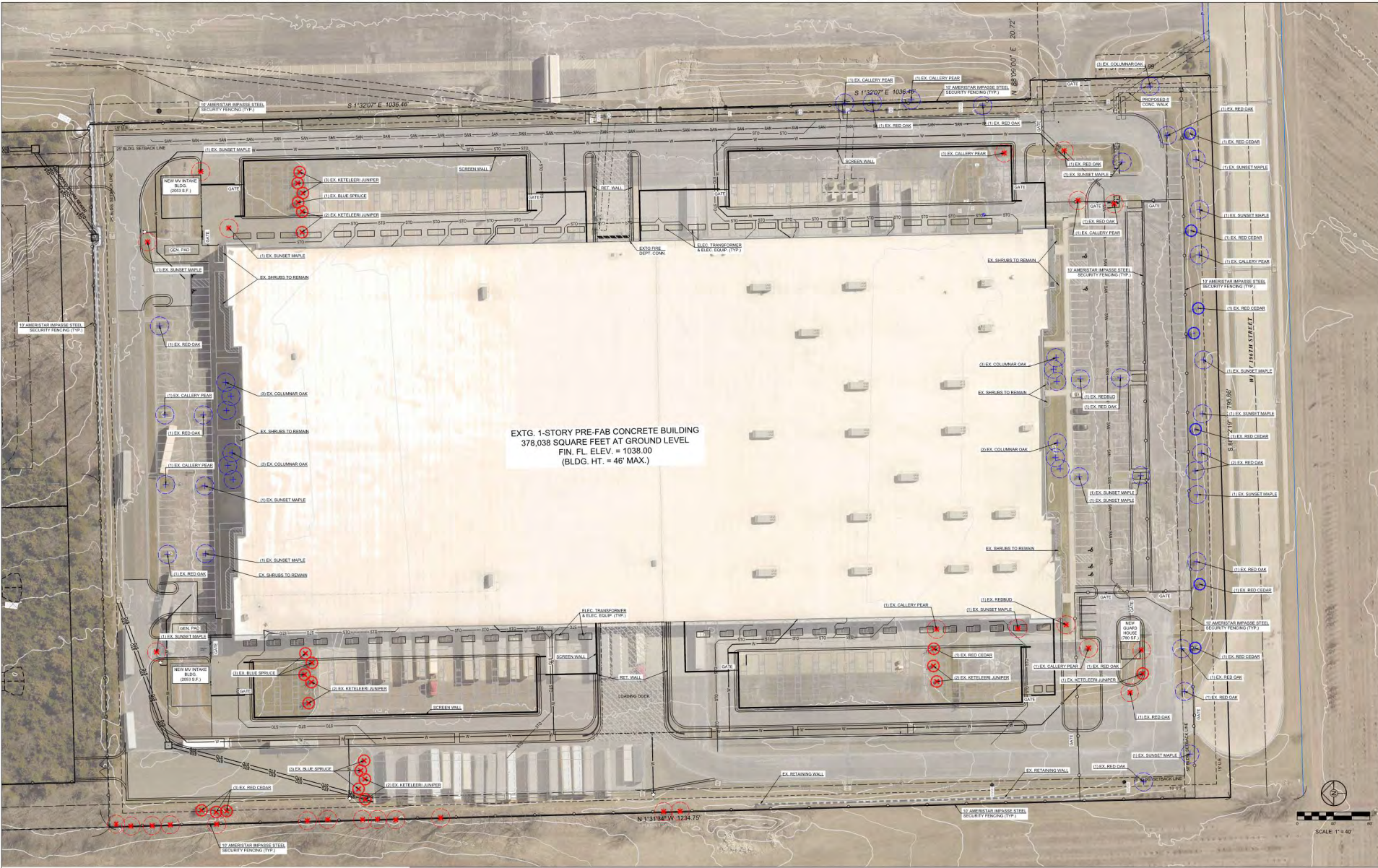

SITE LEGEND:

	4" CONCRETE SIDEWALK
	CONCRETE DRIVE
	ASPHALT DRIVE
	TYPE B CURB & GUTTER
	TYPE B CURB & GUTTER - DRY
	24" WIDE, CONC. RIBBON CURB
	EXISTING CURB & GUTTER
	10' AMERISTAR IMPASSE STEEL SECURITY FENCE
	10' BLACK VINYL-COATED CHAIN LINK FENCE
	EXISTING SIGNIFICANT TREES TO REMAIN
	EXISTING SIGNIFICANT TREES TO BE REMOVED

SCHLAGEL
 ENGINEERS, ARCHITECTS & PLANNERS
 1400 WEST 10TH STREET, SUITE 100, EDGERTON, KANSAS 66527
 (913) 462-5154 • FAX: (913) 462-6800
 WWW.SCHLAGEL.COM

PREPARED BY:
 SCHLAGEL & ASSOCIATES, P.A.

EDGERTON PROJECT - REVISED DEVELOPMENT PLAN

31800 W. 196TH STREET EDGERTON, KANSAS

SCALE: 1" = 40'

DATE: 10/20/2023
 DRAWN BY: JMM
 CHECKED BY: JMM
 DATE PREPARED: 10/20/2023
 PROJECT NUMBER: 23001

EXISTING LANDSCAPE PLAN

L.0.0

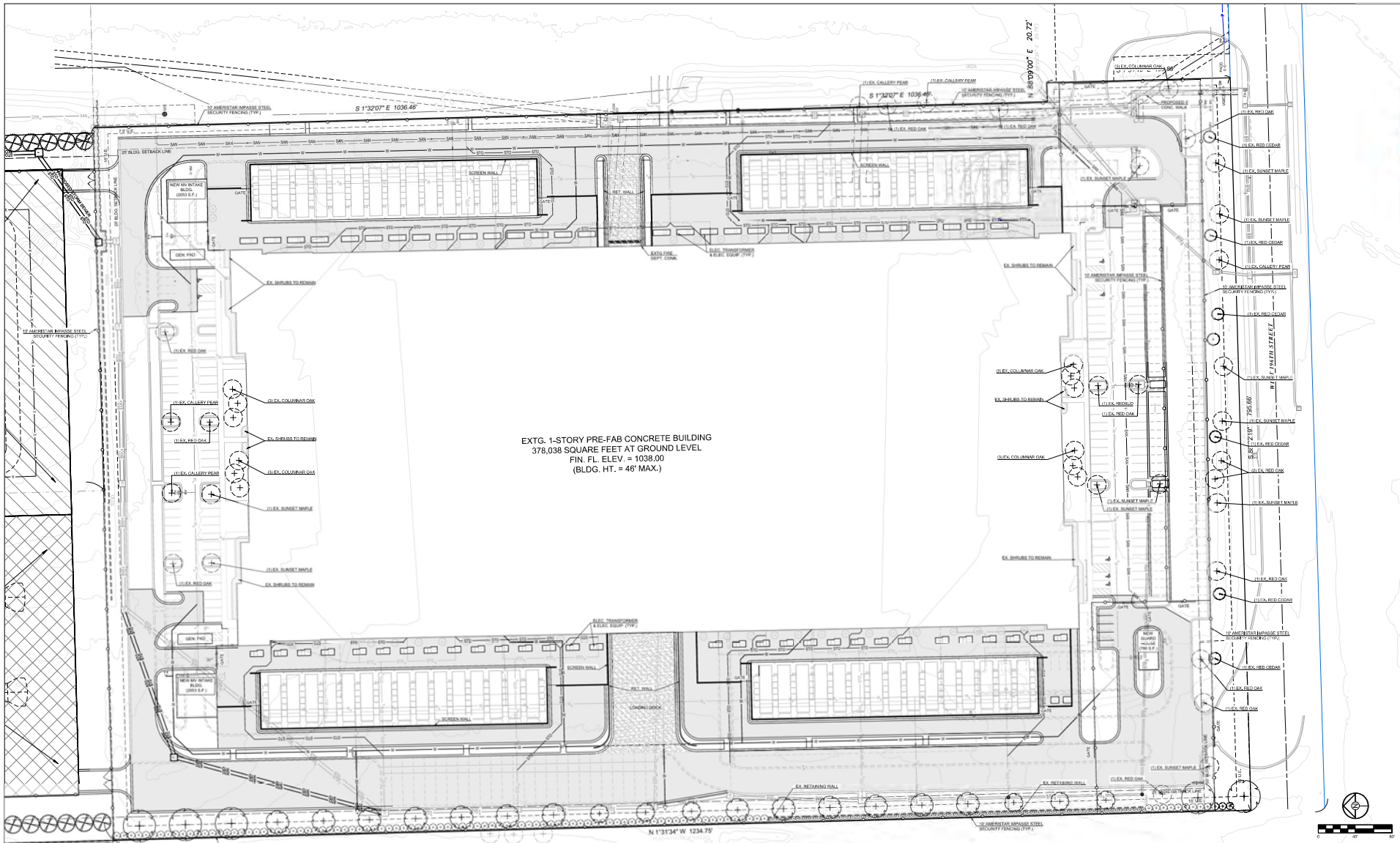

EXTG. 1-STORY PRE-FAB CONCRETE BUILDING
 378,038 SQUARE FEET AT GROUND LEVEL
 FIN. FL. ELEV. = 1038.00
 (BLDG. HT. = 48' MAX.)

PLANT SCHEDULE

SYMBOL	CODE	QTY	BOTANICAL / COMMON NAME	SIZE	CONT.
DECIDUOUS TREES					
⊕	QM	5	QUERCUS MACROCARPA / BURR OAK	2.5' CAL.	848
⊕	QR	13	QUERCUS RUBRA / NORTHERN RED OAK	2.5' CAL.	848
⊕	QS	6	QUERCUS SHUMARDII / SHUMARD OAK	2.5' CAL.	848
EVERGREEN TREES					
⊗	PS	55	PINUS STROBUS / WHITE PINE	8' HT.	848
SHRUBS					
⊕	RA6C	102	RIBES AUREUM / GOLDEN CURRANT	1 GAL.	CONT.
⊕	VT	101	VIBURNUM TIBOLOBIUM / AMERICAN CRANBERRYBUSH	1 GAL.	CONT.

SITE LEGEND:

- 4" CONCRETE SIDEWALK
- CONCRETE DRIVE
- ASPHALT DRIVE
- TYPE B CURB & GUTTER
- TYPE B CURB & GUTTER - DRY
- 24" WIDE CONC. RIBBON CURB
- EXISTING CURB & GUTTER
- 10' AMERISTAR IMPASSE STEEL SECURITY FENCE
- 10' BLACK VINYL-COATED CHAIN LINK FENCE
- EXISTING SIGNIFICANT TREES TO REMAIN

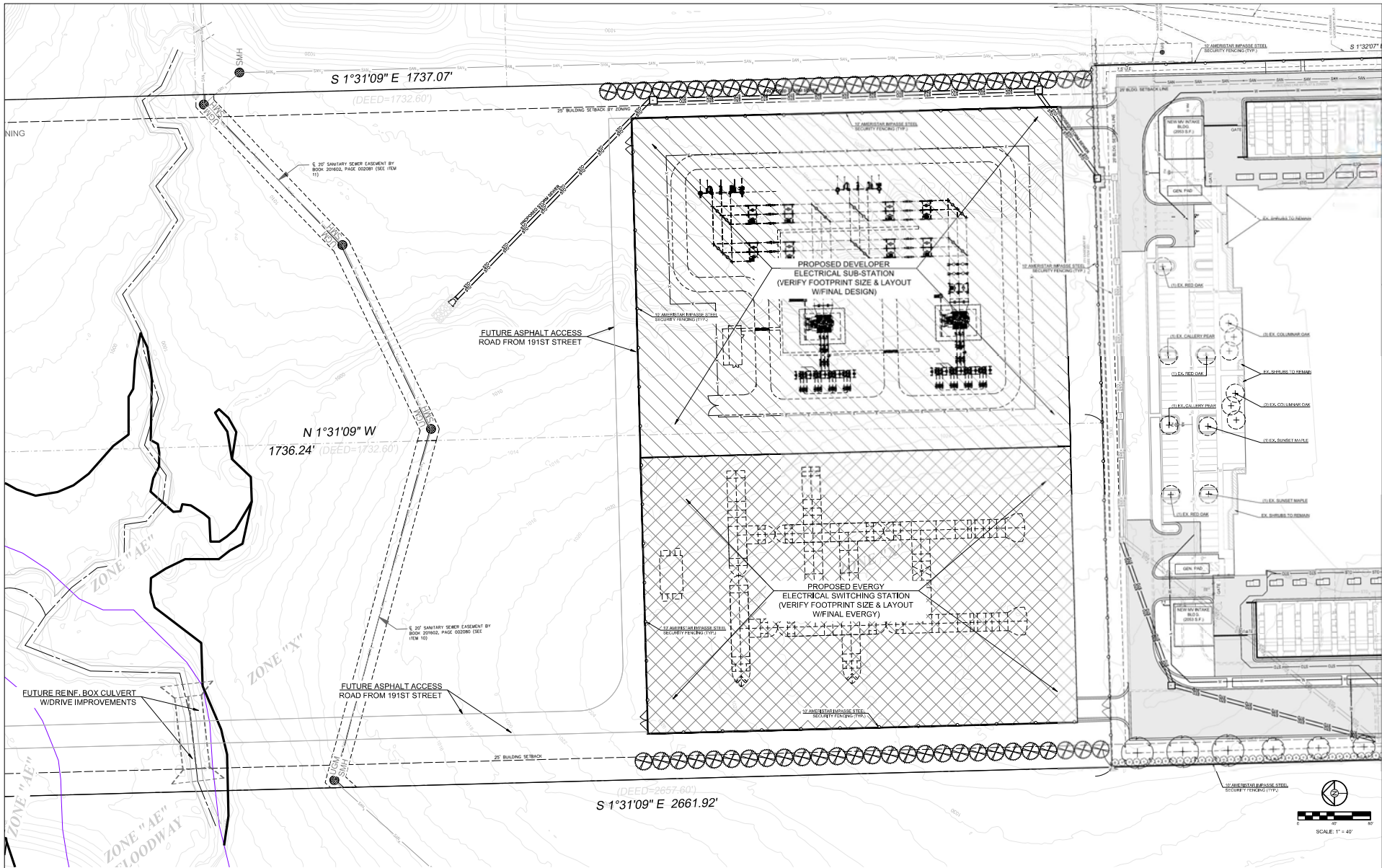

PLANT SCHEDULE

SYMBOL	CODE	QTY	BOTANICAL / COMMON NAME	SIZE	CONT.
DECIDUOUS TREES					
(Symbol)	QM	5	QUERCUS MACROCARPA / BURR OAK	2.5" CAL.	848
(Symbol)	QR	13	QUERCUS RUBRA / NORTHERN RED OAK	2.5" CAL.	848
(Symbol)	QS	6	QUERCUS SHUMARDII / SHUMARD OAK	2.5" CAL.	848
EVERGREEN TREES					
(Symbol)	PS	55	PINUS STROBUS / WHITE PINE	8" HT.	848
SHRUBS					
(Symbol)	RAGC	102	RIBES AUREUM / GOLDEN CURRANT	1 GAL.	CONT.
(Symbol)	VT	101	VIBURNUM TRELUBUM / AMERICAN CRANBERRYBUSH	1 GAL.	CONT.

SITE LEGEND:

- (Symbol) 4" CONCRETE SIDEWALK
- (Symbol) CONCRETE DRIVE
- (Symbol) ASPHALT DRIVE
- (Symbol) TYPE B CURB & GUTTER
- (Symbol) TYPE B CURB & GUTTER - DRY
- (Symbol) 24" WIDE CONC. RIBBON CURB
- (Symbol) EXISTING CURB & GUTTER
- (Symbol) 10' AMERISTAR IMPASSE STEEL SECURITY FENCE
- (Symbol) 10' BLACK VINYL-COATED CHAIN LINK FENCE
- (Symbol) EXISTING SIGNIFICANT TREES TO REMAIN

NO.	DESCRIPTION
1	DESIGNED BY
2	CHECKED BY
3	DATE
4	SCALE
5	PROJECT NO.
6	DATE PLOTTED
7	PLANT SCHEDULE
8	LANDSCAPE PLAN(NORTH)

©2023 Project Controls Architecture, All Rights Reserved. This drawing and the design, construction documents, and related documents prepared by Project Controls Architecture, Inc. are the property of Project Controls Architecture, Inc. and shall remain the confidential property of Project Controls Architecture, Inc. No portion of this drawing may be reproduced, stored in a retrieval system, or transmitted in any form or by any means, electronic, mechanical, photocopying, recording, or by any information storage and retrieval system, without the prior written permission of Project Controls Architecture, Inc.

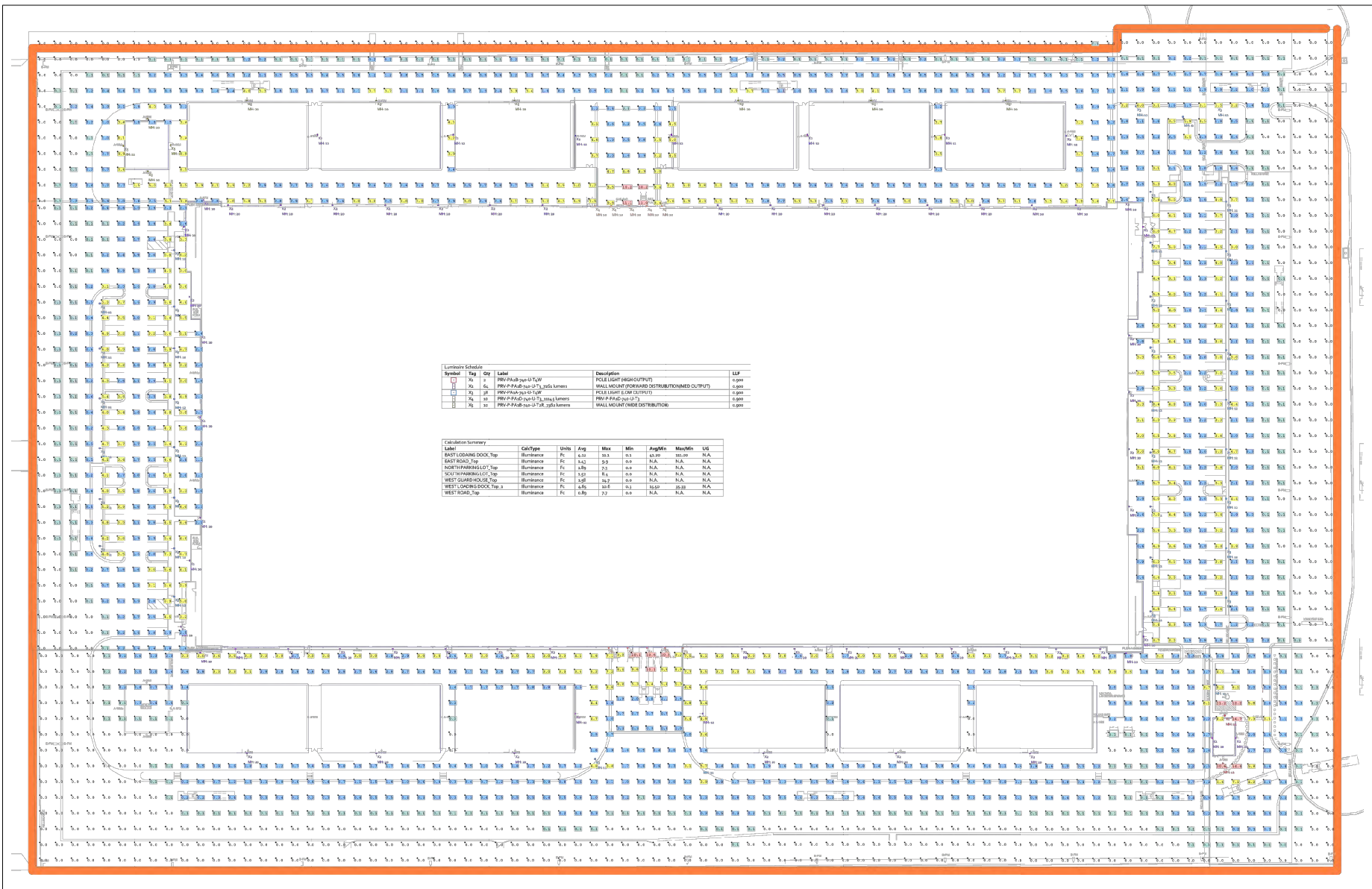

Symbol	Qty	Qty	Label	Description	LEF
□	X1	2	PRV-FAB-pup-1P-FW	POLE LIGHT (FAB-CUT-FW)	0.000
□	X1	56	PRV-FAB-pup-1P-7.5p-Lumens	WALL MOUNT FORWARD DISTRIBUTION (M85-CUT-FW)	0.000
□	X1	10	PRV-FAB-pup-1P-LF	POLE LIGHT (LUM-CUT-FW)	0.000
□	X1	10	PRV-FAB-pup-1P-7.5p-Lumens	PRV-FAB-pup-1P	0.000
□	X1	10	PRV-FAB-pup-1P-7.5p-Lumens	WALL MOUNT (M85-CUT-FW)	0.000

Label	CalcType	Units	Avg	Max	Min	AngleMin	MaxMin	UG
EAST LOADING DOOR, Top	Brightness	Fc	1.10	3.14	0.00	11.00	00.00	N/A
EAST ROAD, Top	Brightness	Fc	1.13	3.39	0.00	N/A	N/A	N/A
NORTH PARKING LOT, Top	Brightness	Fc	1.89	7.00	0.00	N/A	N/A	N/A
SOUTH PARKING LOT, Top	Brightness	Fc	1.53	5.14	0.00	N/A	N/A	N/A
WEST LOADING DOOR, Top	Brightness	Fc	1.48	4.67	0.00	N/A	N/A	N/A
WEST LOADING DOOR, Top, s	Brightness	Fc	1.65	5.05	0.00	10.00	00.00	N/A
WEST ROAD, Top	Brightness	Fc	1.89	7.00	0.00	N/A	N/A	N/A

1 LEVEL 01 - GROUND PLAN - OVERALL
 102 x 107



NO.	REVISION	DATE

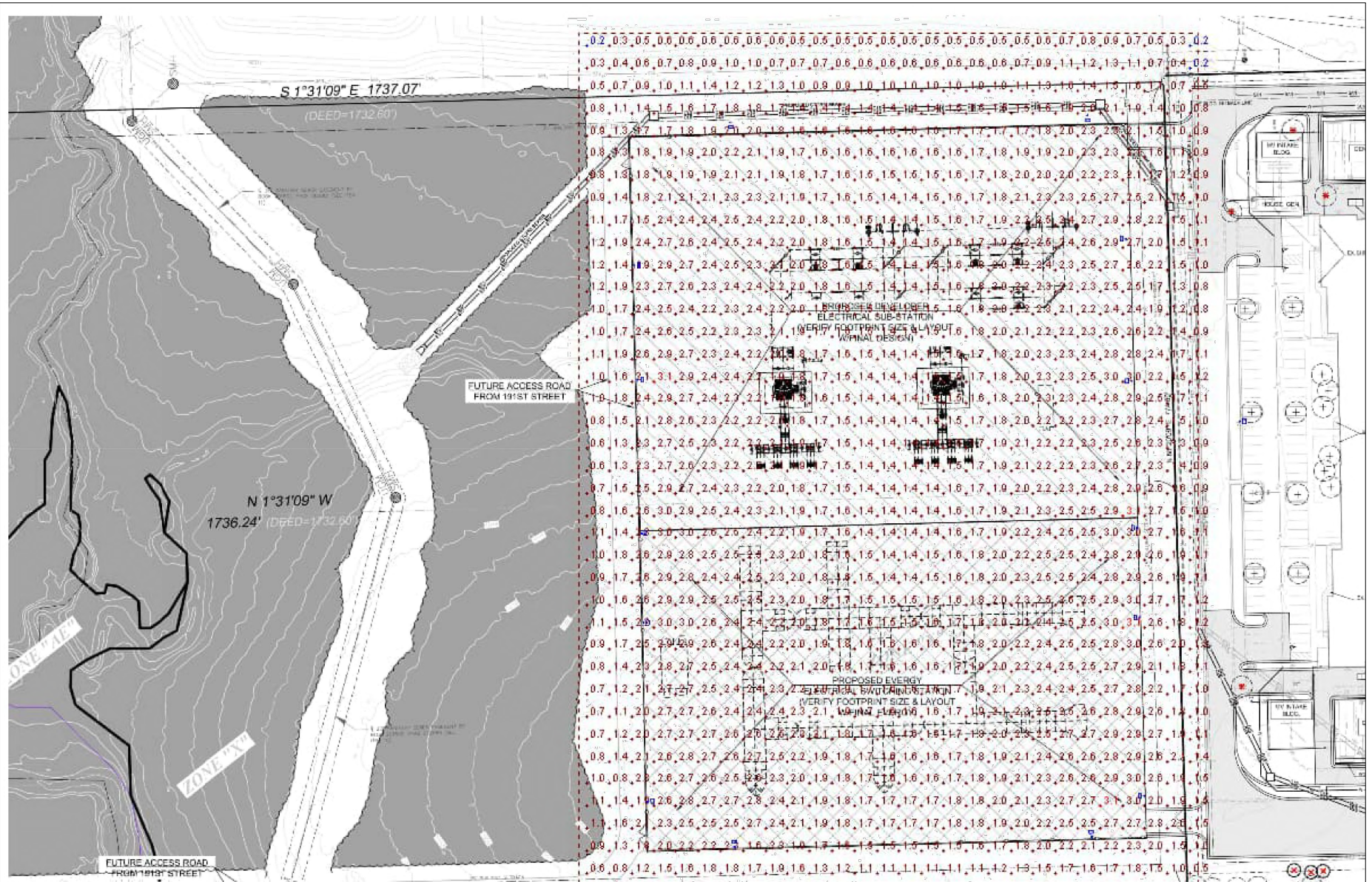

Statistics

Description	Symbol	Avg	Max	Min	Max/Min	Avg/Min
HV Substation Area	+	1.8 fc	3.1 fc	0.2 fc	15.5:1	9.0:1



1 SOUTH ELEVATION @ SCREEN WALLS

2 NORTH ELEVATION @ SCREEN WALLS

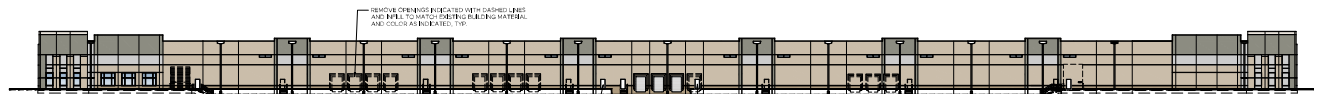

3 WEST ELEVATION



4 EAST ELEVATION

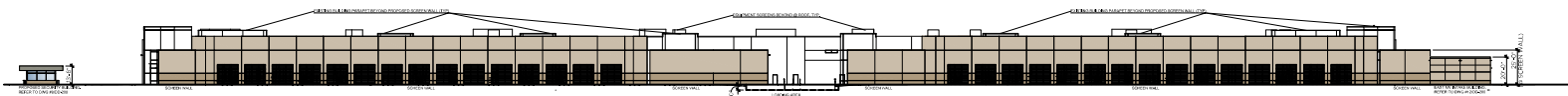

5 EAST ELEVATION @ SCREEN WALLS

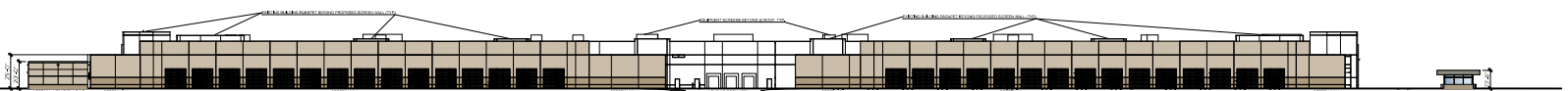

6 WEST ELEVATION @ SCREEN WALLS

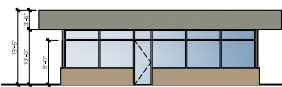

7 PROPOSED SECURITY BUILDING NORTH ELEV.



8 PROPOSED SECURITY BUILDING EAST ELEV.

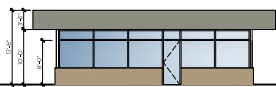

9 PROPOSED SECURITY BUILDING SOUTH ELEV.



10 PROPOSED SEC. BUILDING WEST ELEV.

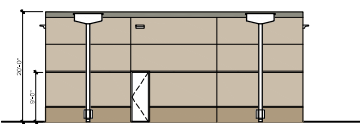

11 EAST MV INTAKE BUILDING NORTH ELEV.

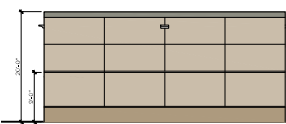

12 EAST MV INTAKE BUILDING EAST ELEV.

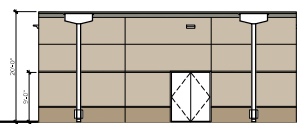

13 EAST MV INTAKE BUILDING SOUTH ELEV.

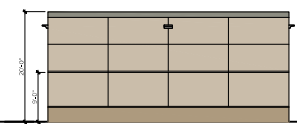

14 EAST MV INTAKE BUILDING WEST ELEV.

COLOR COATING LEGEND
(BY MANUFACTURER)

■	EXTERIOR WALLS
■	EXTERIOR WALLS
■	EXTERIOR WALLS
■	EXTERIOR WALLS
■	EXTERIOR WALLS
■	EXTERIOR WALLS
■	EXTERIOR WALLS
■	EXTERIOR WALLS
■	EXTERIOR WALLS
■	EXTERIOR WALLS

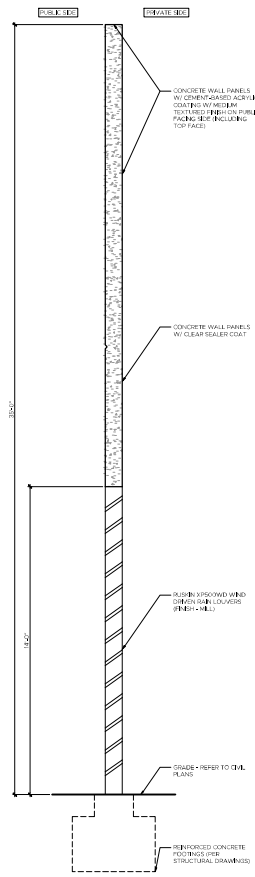

NO.	DATE	DESCRIPTION
1	10/15/2019	ISSUED FOR PERMITS
2	11/15/2019	ISSUED FOR PERMITS
3	12/15/2019	ISSUED FOR PERMITS
4	01/15/2020	ISSUED FOR PERMITS
5	02/15/2020	ISSUED FOR PERMITS
6	03/15/2020	ISSUED FOR PERMITS
7	04/15/2020	ISSUED FOR PERMITS
8	05/15/2020	ISSUED FOR PERMITS
9	06/15/2020	ISSUED FOR PERMITS
10	07/15/2020	ISSUED FOR PERMITS
11	08/15/2020	ISSUED FOR PERMITS
12	09/15/2020	ISSUED FOR PERMITS
13	10/15/2020	ISSUED FOR PERMITS
14	11/15/2020	ISSUED FOR PERMITS
15	12/15/2020	ISSUED FOR PERMITS



NO.	DESCRIPTION	DATE	BY	CHKD.
1	PRELIMINARY	11/11/11	JL	MM
2	CONCEPT	11/11/11	JL	MM
3	DATE PREPARED	11/11/11	JL	MM
4	DATE REVISION	11/11/11	JL	MM
5	DATE REVISION	11/11/11	JL	MM
6	DATE REVISION	11/11/11	JL	MM
7	DATE REVISION	11/11/11	JL	MM
8	DATE REVISION	11/11/11	JL	MM
9	DATE REVISION	11/11/11	JL	MM
10	DATE REVISION	11/11/11	JL	MM

3D VIEWS

SHEET

DD-300



1 AERIAL VIEW @ MAIN ENTRANCE
NOT TO SCALE

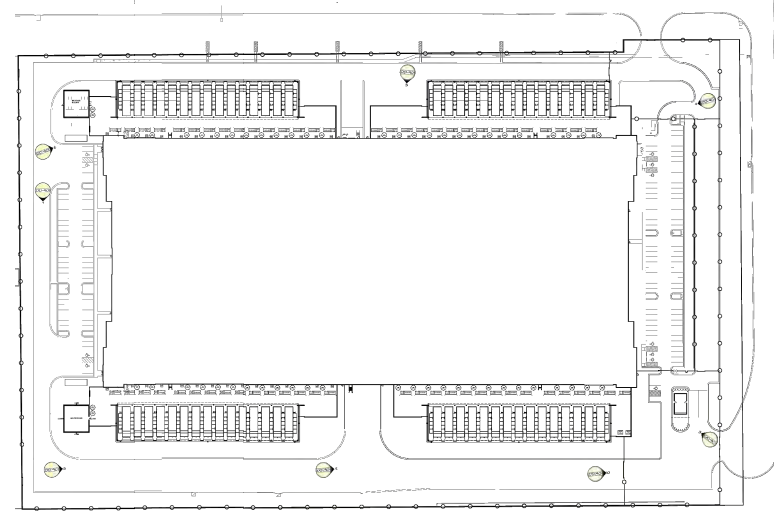

2 KEY PLAN
NOT TO SCALE
YELLOW ARROW INDICATES DIRECTION OF VIEW



3 VIEW @ MAIN ENTRANCE
NOT TO SCALE



4 VIEW @ SOUTH EAST OF SITE
NOT TO SCALE



5 VIEW @ EAST LOADING DOCK
NOT TO SCALE



6 VIEW @ EAST MV INTAKE BLDG
NOT TO SCALE



7 VIEW @ NORTH EAST OF SITE
NOT TO SCALE



8 VIEW @ WEST MV INTAKE BLDG
NOT TO SCALE



9 VIEW @ WEST LOADING DOCK
NOT TO SCALE



10 VIEW @ SOUTH WEST EXIT
NOT TO SCALE

NO.	DESCRIPTION	DATE	BY	CHKD.
1	ISSUED FOR PERMITS	11/11/2020	WJ	WJ
2	ISSUED FOR PERMITS	11/11/2020	WJ	WJ
3	ISSUED FOR PERMITS	11/11/2020	WJ	WJ
4	ISSUED FOR PERMITS	11/11/2020	WJ	WJ
5	ISSUED FOR PERMITS	11/11/2020	WJ	WJ
6	ISSUED FOR PERMITS	11/11/2020	WJ	WJ
7	ISSUED FOR PERMITS	11/11/2020	WJ	WJ
8	ISSUED FOR PERMITS	11/11/2020	WJ	WJ
9	ISSUED FOR PERMITS	11/11/2020	WJ	WJ
10	ISSUED FOR PERMITS	11/11/2020	WJ	WJ

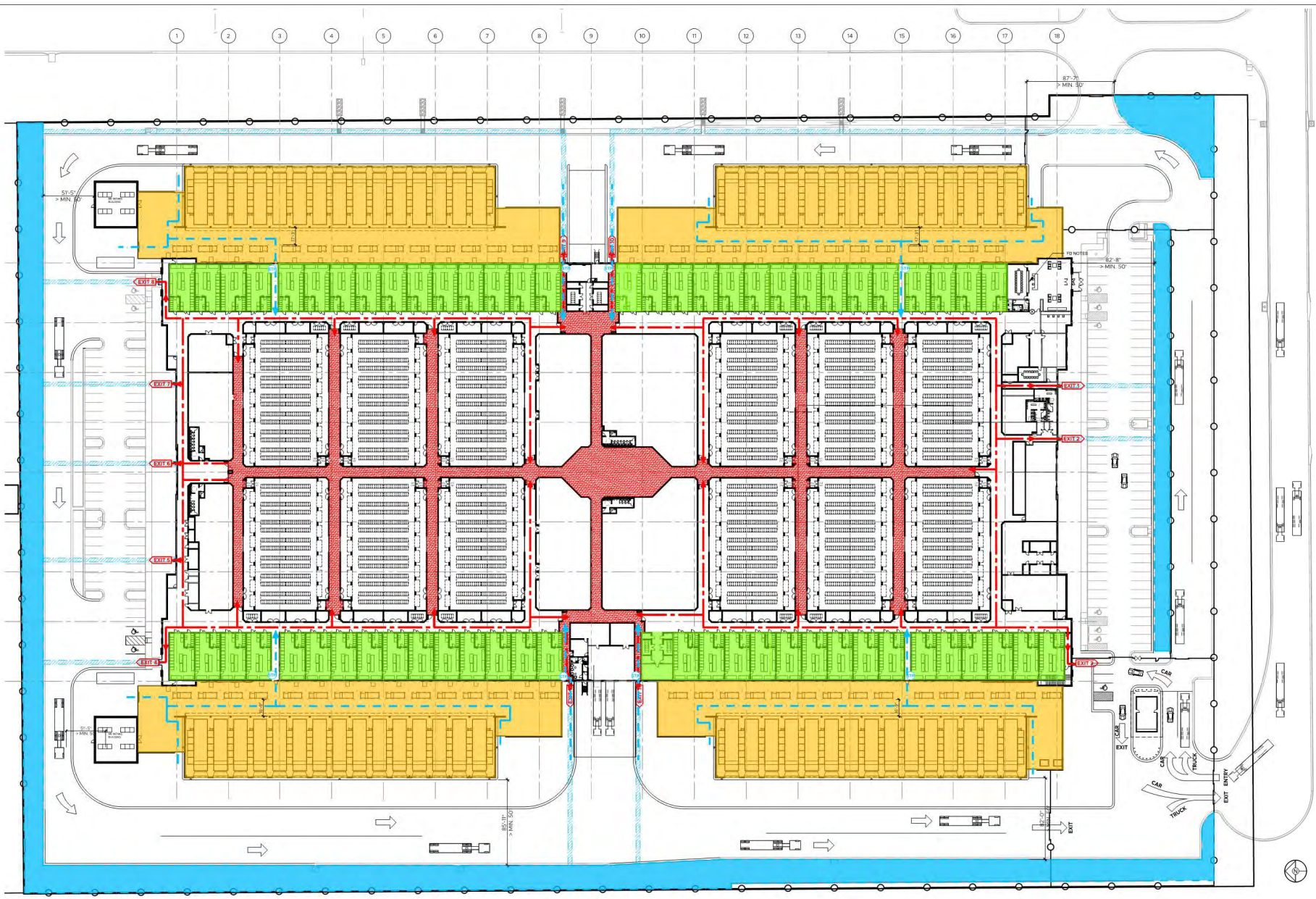

DISPERSAL AREA			
TOTAL OCCUPANT LOAD	MIN. DISPERSAL AREA REQUIRED	PROPOSED DISPERSAL AREA	MIN. DISTANCE (FT) FROM BUILDING ENCLOSURE
1,752	1,752 X 5 SF (PER PERSON) = 8,760 SF	57,393.7 SF	50

LEGEND	
	INGRESS ROUTE - FIRE FIGHTING
	STANDPIPE
	GENERATOR YARD
	H-2 GROUP AREA
	REFUGE AREA
	DISPERSAL AREA
	DISPERSAL ROUTE
	EGRESS PRIMARY TRAVEL ROUTE

1 INGRESS/EGRESS PLAN - ONLY FOR FD REFERENCE

STATEMENT OF PURPOSE

Edgerton Project — Site Plan Application

Applicant: DAMAC Digital Solutions Kansas LLC
Project Address: 31800 W. 196th Street, Edgerton, Kansas 66021
Zoning District: L-P (Logistics Park) — No Change Proposed
Date: April 14, 2026

I. Project Overview

DAMAC Digital Solutions Kansas LLC (“DAMAC Digital”) submits this Statement of Purpose in connection with its Site Plan Application for the development of a high-performance data center located at 13800 W. 196th Street, Edgerton, Kansas, within the Logistics Park Kansas City development.

The project will convert an existing warehouse, located within Logistics Park Kansas City, into a data center engineered for artificial intelligence, cloud, and enterprise workloads. Construction is expected to begin in summer 2026, with operations commencing in the 2027. The existing structure is a one-story pre-fabricated concrete building of 378,038 square feet at ground level.

The scope of work extends beyond the building envelope. DAMAC Digital will construct a dedicated electrical substation north of the site and install advanced power distribution and closed-loop liquid and air-cooling systems engineered to significantly reduce water consumption compared to conventional data center methods. The facility will also house high-density server infrastructure and enterprise-grade networking throughout.

II. Average Day-to-Day Operation

The Edgerton Data Center will operate continuously, 24 hours per day, 7 days per week. The operational profile of this facility differs substantially from other industrial uses that may be familiar to the City.

Physical Activity. Day-to-day operations will be managed by a permanent technical and operations workforce. The facility is not open to the public and has no customer-facing or visitor-facing activity.

Computing Infrastructure. The facility will house high-density server racks, networking equipment, uninterruptible power supply systems, and associated power distribution infrastructure. All computing operations occur entirely within the enclosed building envelope.

Cooling Systems. DAMAC Digital will install advanced power distribution and closed-loop liquid and air-cooling systems engineered to significantly reduce water consumption compared to conventional data center methods. These systems circulate water internally in a sealed loop, materially reducing the freshwater demand and thermal discharge associated with the facility relative to conventional evaporative cooling designs.

Security and Access. The site will be fully enclosed by a 10-foot Ameristar Impasse Steel Security Fence perimeter, with controlled gate access at designated entry points. The site will be monitored continuously by on-site security personnel and electronic surveillance systems.

Power Infrastructure. The site includes a proposed applicant owned electrical substation. A proposed Eversource electrical switching station is also included in the development program. Power is delivered via dedicated high-voltage infrastructure coordinated directly with Eversource. The facility is served by a dedicated on-site substation.

Screening of External Equipment. External mechanical equipment, including generator and chiller units, is screened by a generator/chiller gantry with screenwall on each side of the building. All site lighting is addressed in the photometric plan included in the development plan set.

III. Equipment Replacement Schedule

The facility will house a significant inventory of computing hardware, including server racks, storage arrays, networking equipment, cooling infrastructure, and uninterruptible power supply systems. Industry practice for facilities of this type involves equipment replacement on an approximate 3-to-5-year cycle following initial installation.

Equipment replacement is a periodic, pre-scheduled activity and is not a source of daily traffic or continuous site activity. Replacement deliveries will be coordinated in advance via freight carrier arrangements and will be managed to minimize any disruption to surrounding roadways. Decommissioned equipment will be removed via freight pickup and responsibly redeployed or recycled.

IV. Generator Testing Hours

Generator systems will be subject to routine periodic testing to verify operational readiness, consistent with industry-standard practice for mission-critical facilities. Routine scheduled testing is generally conducted during normal weekday business hours. In the event of an unplanned utility outage, generators will operate as necessary to maintain facility continuity; such events are unscheduled and are a function of utility grid conditions rather than planned facility operations.

V. Traffic Generation

Traffic generated by the Edgerton Data Center will differ materially in character from other large-scale industrial or logistics uses within Logistics Park Kansas City. The Planning Commission is asked to consider two distinct phases.

Construction Phase. Construction is anticipated to commence in summer 2026. During this period, the site will experience traffic associated with material deliveries, contractor workforce commuting, and specialty subcontractor mobilizations. At peak construction activity, site-generated traffic is anticipated and will be primarily concentrated during morning and afternoon shift changes. All traffic control measures required in connection with the proposed construction will be implemented in conformance with applicable standards, and construction vehicle staging and delivery scheduling will be managed to minimize conflicts with existing traffic on surrounding roadways.

Operational Phase. Once operational, traffic generation will be minimal and predictable. Operational traffic is anticipated to generate approximately 20 vehicle trips per day, consisting of: employee commuter trips for a permanent technical and operations workforce; occasional delivery and service vehicles for routine consumables and maintenance; and periodic equipment replacement deliveries on a multi-year cycle, as described in Section III. The facility has no public-facing or customer-facing traffic component of any kind, which distinguishes this use materially from other commercial and industrial uses of comparable building area.

VI. Additional Pertinent Information

Economic Impact. The project represents one of the largest private investments in Johnson County in recent years and is being advanced in partnership with state and local economic development programs. The facility will generate significant property and sales tax revenue for the City of Edgerton and Johnson County while placing relatively low demand on public services compared to other developments of similar scale. A comprehensive economic and fiscal impact study is underway and will be shared with the community upon completion.

Water Design. The facility employs closed-loop liquid cooling systems that circulate water internally in a sealed loop, eliminating the need for evaporative cooling towers and materially reducing ongoing freshwater consumption relative to conventional data center cooling designs.

Fuel Storage. Each generator pod is equipped with an integral belly tank — a sub-base fuel tank housed within the generator skid — for on-site diesel fuel storage. The applicant acknowledges the requirement under the L-P District regulations that exterior fuel tanks be located below ground and that all below-ground fuel tanks meet, at a minimum, International Building Code, International Fire Code, and Kansas Department of Health and Environment requirements.

Stormwater Management. A Preliminary Stormwater Management Report has been prepared in connection with this application and is submitted as a companion document. The development plan incorporates proposed storm sewer infrastructure designed to manage stormwater runoff in compliance with applicable City of Edgerton and Johnson County requirements.

Zoning Compliance. The proposed data center use has been confirmed as permitted by-right in the L-P (Logistics Park) Zoning District by the City of Edgerton's Development Services Director. No rezoning, variance, or special use permit is requested in connection with this application.

Edgerton Project – Revised Development Plan

4/20/26

Response to submission comment regarding proposed use of gravel received 4/14/26.

Comment:

13. Provide details regarding the development of the proposed transfer yard and substation.

- a. Information regarding the use of gravel as a mandated material by the electrical company was requested by the City at a pre-application meeting but has yet to be provided. The City does not allow gravel as a surface finish material unless mandated for safety reasons.

Response as provided by Applied High Voltage, LLC:

This is due to the requirements of IEEE / ANSI Standard 80 entitled “Safety in AC Substation Grounding”. The technical reason is that substations must be designed with a “ground grid” to facilitate a low resistance return path to the source whenever an unbalanced short circuit occurs. Please note that the overwhelming majority of short circuits are unbalanced. Without this low resistance return path a very dangerous high voltage will build up that can cause serious injury and equipment damage in and nearby the substation. This is because a high voltage builds up whenever current flows through a high resistance (Ohm’s Law).

The Ground Grid is a series of bare conductors and ground rods (either copper or copper coated steel) under the substation to create a low resistance path to “deep earth” and allows the short circuit current to return to it’ source. This also allows protective devices in the system to quickly identify the short circuit and open the associated circuit breakers and disconnect the part of the system where the short circuit is located.

The amount of current flowing through the ground grid can be extremely high and when a person is in the area, a very high voltage can be induced between parts of the body called step (between the person’s legs) and touch (between the person and whatever they touch) voltages. The stone in a substation is installed on top of the ground grid to insulate personnel from these voltages for safety. Step and Touch potentials are one of the key calculation results determined by the Grounding Study performed during detailed engineering of a substation. The ANSI / IEEE Standard defines allowable step and touch

potentials in a substation. These values were determined in cooperation with a series of medical professionals several years ago.

The reason this is done in substations and not in lower voltage areas is that since the system in those areas is at a lower voltage and the equipment is grounded the worst case step and touch voltages that can arise are much lower and an installation layer like the crushed stone in a substation is not necessary (as defined by the National Electric Code).